

Ruijie Reyee RG-ES Series Switches

Implementation Cookbook

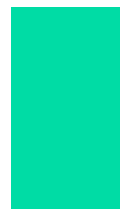
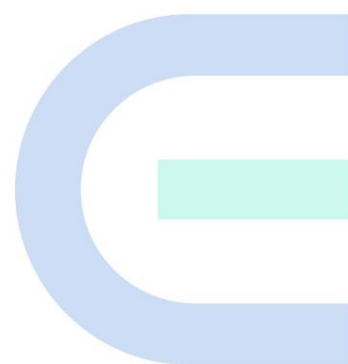

Copyright

Copyright © 2026 Ruijie Networks

All rights are reserved in this document and this statement.

Without the prior written consent of Ruijie Networks, any organization or individual shall not reproduce, extract, back up, modify, or propagate the content of this document in any manner or in any form, or translate it into other languages or use some or all parts of the document for commercial purposes.

 and other Ruijie networks logos are trademarks of Ruijie Networks.

All other trademarks or registered trademarks mentioned in this document are owned by their respective owners.

Disclaimer

The products, services, or features you purchase are subject to commercial contracts and terms, and some or all of the products, services, or features described in this document may not be available for you to purchase or use. Except for the agreement in the contract, Ruijie Networks makes no explicit or implicit statements or warranties with respect to the content of this document.

The names, links, descriptions, screenshots, and any other information regarding third-party software mentioned in this document are provided for your reference only. Ruijie Networks does not explicitly or implicitly endorse or recommend the use of any third-party software and does not make any assurances or guarantees concerning the applicability, security, or legality of such software. You should choose and use third-party software based on your business requirements and obtain proper authorization. Ruijie Networks assumes no liability for any risks or damages arising from your use of third-party software.

The content of this document will be updated from time to time due to product version upgrades or other reasons, Ruijie Networks reserves the right to modify the content of the document without any notice or prompt.

This manual is designed merely as a user guide. Ruijie Networks has tried its best to ensure the accuracy and reliability of the content when compiling this manual, but it does not guarantee that the content of the manual is completely free of errors or omissions, and all the information in this manual does not constitute any explicit or implicit warranties.

Preface

Intended Audience

This document is intended for:

- Network engineers
- Technical support and servicing engineers
- Network administrators

Technical Support

- The official website of Ruijie Reyee: <https://reyee.ruijie.com>
- Technical Support Website: <https://reyee.ruijie.com/en-global/support>
- Case Portal: <https://www.ruijie.com/support/caseportal>
- Community: <https://community.ruijie.com>
- Technical Support Email: service_rj@ruijie.com
- Online Robot/Live Chat: <https://reyee.ruijie.com/en-global/rita>

Conventions

1. GUI Symbols

Interface symbol	Description	Example
Boldface	1. Button names 2. Window names, tab name, field name and menu items 3. Link	1. Click OK . 2. Select Config Wizard . 3. Click the Download File link.
>	Multi-level menus items	Select System > Time .

2. Signs

This document also uses signs to indicate some important points during the operation. The meanings of these signs are as follows:

Warning

An alert that calls attention to important rules and information that if not understood or followed can result in data loss or equipment damage.

Note

An alert that calls attention to essential information that if not understood or followed can result in function failure or performance degradation.

 Instruction

An alert that contains additional or supplementary information that if not understood or followed will not lead to serious consequences.

 Specification

An alert that contains a description of product or version support.

3. Instruction

This manual is used to guide users to understand the product, install the product, and complete the configuration.

- The example of the port type may be different from the actual situation. Please proceed with configuration according to the port type supported by the product.
- The example of display information may contain the content of other product series (such as model and description). Please refer to the actual display information.
- The routers and router product icons involved in this manual represent common routers and layer-3 switches running routing protocols.

Ruijie Reyee RG-ES Series Switches Implementation Cookbook

This cookbook consists of multiple independent volumes, introducing the installation, deployment, and web-based configuration of the RG-ES Series Switches, including:

- 00- Cover
- 01- Preface
- 02- Overview
- 03- Installation Guide
 - 01-RG-ES103F-P Switch Installation Guide.docx
 - 02-RG-ES205GC-V2 Switch Installation Guide.docx
 - 03-RG-ES207GS-AC-OD Switch Installation Guide.docx
 - 04-RG-ES207GS-HP Switch Installation Guide.docx
 - 05-RG-ES207GS-LP Switch Installation Guide.docx
 - 06-RG-ES207GS-P Switch Installation Guide.docx
 - 07-RG-ES207GS-PI-OD Switch Installation Guide.docx
 - 08-RG-ES208GC-V2 Switch Installation Guide.docx
 - 09-RG-ES211GS-LP Switch Installation Guide.docx
 - 10-RG-ES211GS-P Switch Installation Guide.docx
 - 11-RG-ES216GC2MS Switch Installation Guide.docx
 - 12-RG-ES224GC2MS Switch Installation Guide.docx
 - 13-RG-ES228GS-P-V2 Switch Installation Guide.docx
 - 14-RG-ES220GS-P-V2 Switch Installation Guide.docx
- 04- RG-ES, NBS3000 Series Switches 1.0(1)B1P52 Configuration Guide.docx

Contents

1 Overview	3
1.1 About the RG-ES103F-P	3
1.2 Equipment Appearance	3
1.1.1 Front Panel.....	3
1.2.2 LEDs	4
1.3 Cooling.....	5
1.4 Technical Specifications	5
2 Preparing for Installation	8
2.1 Package Contents.....	8
2.2 Safety Guidelines.....	8
2.2.1 General Precautions	8
2.2.2 Chassis-Lifting Guidelines	8
2.2.3 Electricity Safety	8
2.2.4 Preventing ESD Damage.....	9
2.3 Site Requirements	10
2.3.1 Floor Loading	10
2.3.2 Airflow.....	10
2.3.3 Space	10
2.3.4 Temperature and Humidity.....	10
2.3.5 Cleanliness.....	10
2.3.6 Grounding	11
2.3.7 Preventing Electromagnetic Interference	12
2.3.8 Surge Protection	12

2.3.9 Installation Site.....	12
2.4 Tools	12
3 Installing the Switch	13
3.1 Before You Begin.....	13
3.2 Installing the Equipment	13
3.2.1 Wall Mount	13
3.2.2 Workbench Mount.....	14
3.3 Verifying Installation.....	14
4 Commissioning.....	15
4.1 Startup Check	15
4.1.1 Checking before the Device is Powered on	15
4.1.2 Checking after Program Startup (Recommended)	15
5 Common Troubleshooting.....	16
5.1 General Troubleshooting Flowchart	16
5.2 Common Faults.....	16
6 Appendix.....	17
6.1 Connectors and Media.....	17
6.2 Lightning Protection	17
6.2.1 Installing the AC Power Arrester (Power Strip with Surge Protection)	17
6.2.2 Installing the Ethernet Port Arrester.....	18

1 Overview

1.1 About the RG-ES103F-P

The RG-ES103F-P is a 100 Mbps Ethernet PoE switch, which provides three 10/100BASE-T ports and supports line-rate forwarding on all ports. Two of the ports support Power over Ethernet (PoE), allowing the switch to serve as the Power Sourcing Equipment (PSE). The switch can automatically detect and identify powered devices (PDs) that comply with the IEEE 802.3at or IEEE 802.3af standard, and supply power to them through Ethernet cables.

Figure 1-1 RG-ES103F-P Appearance

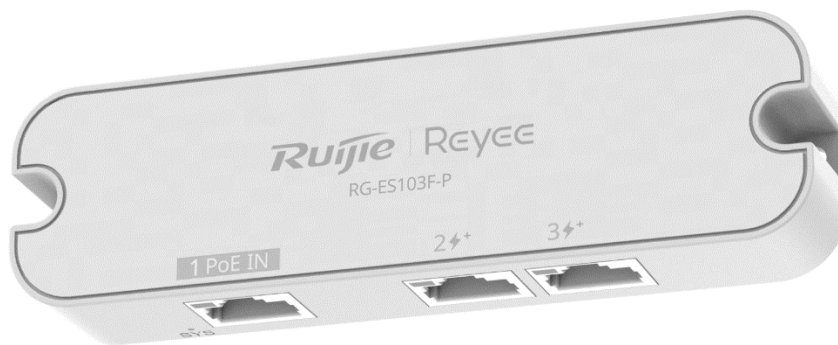

1.2 Equipment Appearance

1.1.1 Front Panel

Figure 1-2 Front Panel of the RG-ES103F-P

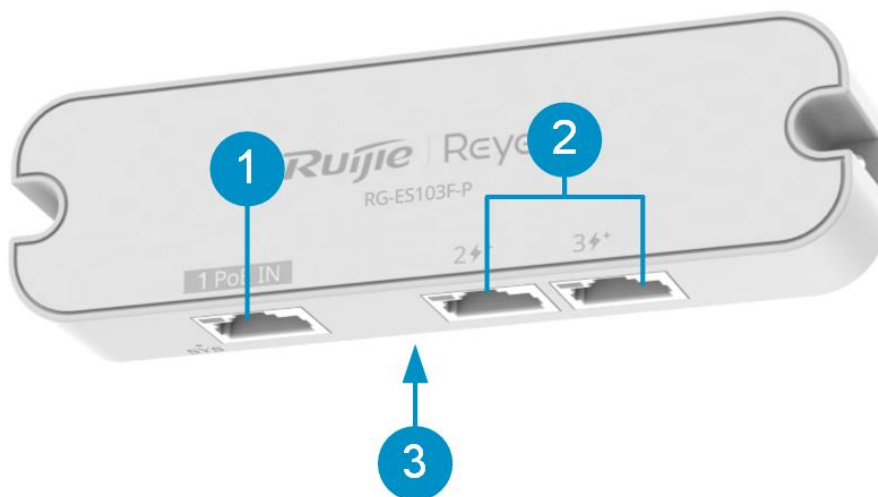

Note

⚡+ indicates the PoE+ ports, which are compliant with IEEE 802.3at, and backward compatible with IEEE 802.3af.

Table 1-1 Components on the Front Panel

No.	Component	Silkscreen	Description
1	RJ45 port	1 PoE IN	10/100BASE-T PoE In port, compliant with IEEE 802.3at (PoE+) and IEEE 802.3af (PoE).
2	RJ45 port	2 ⚡+ 3 ⚡+	Two 10/100BASE-T ports, supplying power to PDs through PoE.
3	Nameplate	-	It is located at the bottom of the switch.

1.2.2 LEDs

Figure 1-3 RG-ES103F-P LEDs

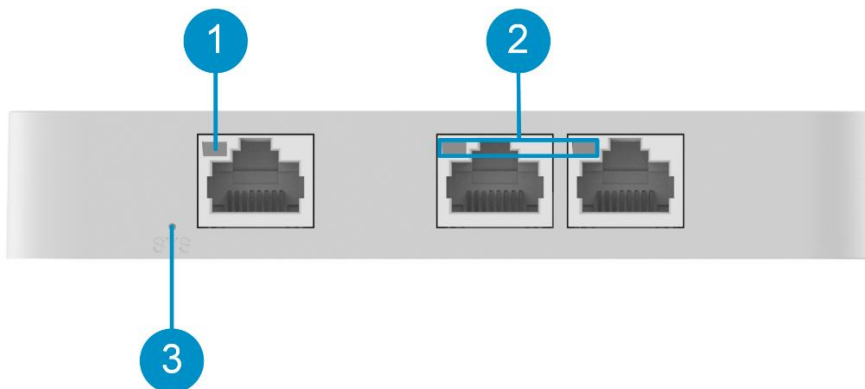

Table 1-2 LEDs

No.	Component	Silkscreen	Description
1	RJ45 port LED	1 PoE IN	<ul style="list-style-type: none"> ● Off: The port is not connected. ● Solid green: The port is operating at 10 Mbps or 100 Mbps, but is not receiving or sending data. ● Blinking green: The port is operating at 10 Mbps or 100 Mbps, and is receiving or sending data.
2	RJ45 port LED	2 ⚡+ 3 ⚡+	<ul style="list-style-type: none"> ● Off: The port is not connected. ● Solid green: The port is operating at 10 Mbps or 100 Mbps, but is not receiving or sending data. ● Blinking green: The port is operating at 10 Mbps or 100 Mbps, and is receiving or sending data.

No.	Component	Silkscreen	Description
3	System status LED	SYS	<ul style="list-style-type: none"> ● Off: The switch is not powered on. ● Solid on: The switch is powered on.

1.3 Cooling

The RG-ES103F-P adopts fanless design and uses natural cooling. To ensure that the equipment works properly in the specified environment, a minimum clearance of 10 cm (3.94 in.) must be maintained around the equipment for air circulation and ventilation.

1.4 Technical Specifications

Warning

- The equipment falls into Class A. Therefore, the equipment room should be located away from the residential area. Otherwise, the equipment room should meet construction specifications to avoid noise and radio interference.
- This equipment is not suitable for use in locations where children are likely to be present.
- Operation of this equipment in a residential environment could cause radio interference.

Table 1-3 Technical Specifications

Parameter Type	Parameter Name	RG-ES103F-P
System Specifications	Forwarding rate	0.45 Mpps
	Switching capacity	0.6 Gbps(Gbit/s)
Port Specifications	Total number of RJ45 ports	3
	Number of 10/100BASE-T ports	3
	LEDs	1 x System indicator light 3 x Network port indicator lights
Power Supply and Consumption	Power supply	PoE Ethernet Power Supply
	Power input	PoE/HPoE Ethernet Power Supply: Compliant with 802.3af/at Ethernet Power Supply Standards
	Maximum power consumption	32.5 W (with full PoE load) 2.5 W (without PoE load)
	Number of PoE Out ports	2

Parameter Type	Parameter Name	RG-ES103F-P
	Number of PoE/PoE+ Out ports	2
	PoE Out standard	IEEE 802.3af/at (PoE/PoE+)
	PoE power pins	1-2(+), 3-6(-)
	PoE budget per port	30 W
	PoE budget	30 W
Dimensions and Weight	Product dimensions (W x D x H)	120mm x 34mm x 20.5mm
	Weight	0.05 kg (0.11 lbs)
	Shipping weight	0.114 kg (0.25 lbs)
	Casing	plastic
Environment and Reliability	Mounting options	Wall/Desk
	Cooling	Natural cooling
	MTBF	200,000 hours
	ESD protection	Air discharge: 6 kV Contact discharge: 4 kV
	Surge protection	Service port: ± 4 kV for common mode
	Operating temperature	0°C~40°C
	Storage temperature	-40°C~70°C
	Operating humidity	10% RH to 90% RH (non-condensing)
	Storage humidity	5% RH to 95% RH (non-condensing)
	Altitude	-500 m to +5,000 m (-1,640.42 ft. to +16,404.20 ft.)
Certification and Regulatory Compliance	EMC	EN 55032 EN 61000-3-2 EN 61000-3-3 EN 55035 EN 300 386
	Safety compliance	EN 62368-1

Parameter Type	Parameter Name	RG-ES103F-P
		IEC 62368-1
	Certification	CE, CB

2 Preparing for Installation

2.1 Package Contents

Table 2-1 Package Contents

No.	Item	Quantity
1	RG-ES103F-P switch	1
2	User Manual	1
3	Warranty Card	1

2.2 Safety Guidelines

Note

- To avoid personal injury or equipment damage, review the safety guidelines in this chapter before you begin the installation.
- The following safety guidelines may not include all the potentially hazardous situations.

2.2.1 General Precautions

- Never operate the equipment in a wet environment, and avoid any liquids inside it. Keep the chassis clean and dust-free.
- Keep the equipment away from heat sources.
- Keep the equipment away from walk areas.
- During installation and maintenance, do not wear loose clothing or ornament that may get caught in the chassis.
- Keep tools and accessories away from walk areas.

2.2.2 Chassis-Lifting Guidelines

- Avoid moving the equipment frequently.
- Turn off all power supplies and disconnect all cables before lifting or moving the equipment.

2.2.3 Electricity Safety

Warning

- Any deviation from standard or improper electrical operations can result in accidents such as fires or electric shocks, potentially causing severe or even fatal harm to both individuals and equipment.
- Direct or indirect touch through a wet object on high-voltage and mains supply can bring a fatal danger.

- Always observe the local regulations and standards. Only qualified personnel should be allowed to operate the equipment.
- Carefully check the work area for potential hazards, including ungrounded power system, absent safety grounds, and damp floors.
- Locate the emergency power-off switch in the room before installation. In the case of an accident, cut off the power supply immediately.
- Never assume that power is connected to or disconnected from a circuit. Always check.
- Select the right leakage protector (also called "leakage current switch" or "leakage current breaker") for the power supply system. This equipment automatically disconnects the power supply in the event of leakage and the risk of electric shock. A leakage protector should meet the following requirements:

- The rated leakage action current of each leakage protector must be at least twice the total maximum leakage current of all connected power supplies.

Example:

If a system has 16 identical power supplies, each with a maximum leakage current of 3.5 mA:

Total leakage current = $16 \times 3.5 \text{ mA} = 56 \text{ mA}$

For a 30 mA leakage protector:

Maximum number of power supplies per protector = $30 \text{ mA} / 2 / 3.5 \text{ mA} \approx 4$

Therefore, only four power supplies can be connected to one 30 mA leakage protector.

To support 16 power supplies, at least four 30 mA leakage protectors are required.

Always ensure:

Rated leakage operating current/2 > Total maximum leakage current of connected power supplies

- The rated leakage non-action current of a leakage protector should be 50% of the leakage action current. If the non-action current value is too small, the high sensitivity level can cause the circuit to break, leading to power cutoff and service interruption, even if the leakage current value is normal.

For example, if a leakage protector has a rated leakage action current of 30 mA, the rated leakage non-action current should be 15 mA. The leakage protector will not activate unless the leakage current exceeds 15 mA.

 **Caution**

- To ensure personal safety, each leakage protector in the system must have a rated leakage action current equal to or below 30 mA, which is the recognized safety threshold for human body current. If the total leakage current of the system exceeds twice the 30 mA limit, the system must be equipped with two or more leakage protectors to maintain safety.
 - The leakage current values vary with equipment. For the leakage current value of each equipment model, see "Technical Specifications."
-

2.2.4 Preventing ESD Damage

- Ensure that the chassis is connected to earth ground.
- Keep the site as dust free as possible.
- Maintain appropriate humidity conditions.

- Before installing any pluggable modules, wear an anti-ESD wrist strap and make sure that it is properly grounded.
- Avoid contact between the printed circuit boards and clothing. The anti-ESD wrist strap only protects the printed circuit boards from ESD voltages on the body. ESD voltages on clothing can still cause damage.

2.3 Site Requirements

The equipment must be installed indoors for normal operation and prolonged service life.

The installation site must meet the following requirements.

2.3.1 Floor Loading

Assess the combined weight of the equipment and its accessories, such as chassis and power modules, and verify that the floor under the rack can bear the weight.

2.3.2 Airflow

The equipment adopts natural cooling. Reserve a sufficient clearance around the equipment to ensure proper ventilation.

2.3.3 Space

Do not install the equipment against a wall. Instead, maintain a minimum clearance of 10 cm (3.94 in.) around the equipment for heat dissipation and equipment maintenance.

2.3.4 Temperature and Humidity

To ensure the normal operation and a prolonged service life of the equipment, maintain an appropriate temperature and humidity in the installation environment.

Prolonged exposure to inappropriate temperature and humidity conditions can cause damage to the equipment.

- In an environment with high relative humidity, insulating materials are prone to poor insulation or even electricity leakage.
- In an environment with low relative humidity, insulating gaskets may shrink, resulting in screw loosening.
- In a dry environment, static electricity is more likely to occur, posing a risk to the internal circuits of equipment.
- A high temperature can accelerate the aging process of insulation materials, greatly reducing the availability of the equipment and severely affecting its service life.

2.3.5 Cleanliness

Dust poses a significant hazard to the equipment. Dust on the enclosure causes electrostatic adhesion, leading to poor contact of the metallic joints. Electrostatic adhesion is more likely to occur in an indoor environment with relatively low humidity, not only affecting the service life of the equipment, but also causing communication faults. The following table lists the requirements for dust concentration and particle size in the equipment room.

Table 2-2 Requirements for Dust

Particle Diameter	Unit	Concentration
≥ 0.5 μm	Particles/m ³	≤ 3.5 × 10 ⁶

$\geq 5 \mu\text{m}$	Particles/m ³	$\leq 3.5 \times 10^6$
----------------------	--------------------------	------------------------

Apart from dust, there are also requirements on the salt, acid, and sulfide in the air of the equipment room. These harmful substances will accelerate metal corrosion and component aging. Therefore, the equipment room should be properly protected against harmful gases, such as sulfur dioxide, hydrogen sulfide, nitrogen dioxide, and chlorine gas. The following table lists the limits on harmful gases.

Table 2-3 Requirements for Gases

Gas	Average (mg/m ³)	Maximum (mg/m ³)
Sulfur dioxide (SO ₂)	0.3	1.0
Hydrogen sulfide (H ₂ S)	0.1	0.5
Nitrogen dioxide (NO ₂)	0.5	1.0
Chlorine gas (Cl ₂)	0.1	0.3

Note

Average refers to the average value of harmful gases measured in a week. **Maximum** refers to the upper limit of harmful gases measured in a week for up to 30 minutes every day.

2.3.6 Grounding

A proper grounding system is crucial for ensuring stable and reliable operation, as well as preventing lightning strikes and interference. Carefully check the grounding conditions at the installation site according to the grounding requirements, and complete grounding properly based on the site situation.

- Safety Grounding

Ensure that the power distribution system is securely grounded if the equipment uses the AC power supply. Otherwise, electric shocks may occur when the insulation resistance between the power module and the chassis decreases.

Caution

- The building should provide a protective ground connection to ensure that the equipment is connected to a protective ground.
- Verify that the AC socket is reliably connected to the protective grounding system of the building. If not, a protective grounding wire should be used to connect the protective grounding lug of the AC socket to the protective grounding system of the building.

- Lightning Grounding

The lightning protection system is an independent system composed of a lightning rod, a downlead conductor, and a connector connected to the grounding system. The grounding system is typically used for power reference grounding and safety grounding. Lightning grounding is required only for facilities, and is not required for the equipment.

- EMC Grounding

Electromagnetic compatibility (EMC) grounding includes shielded grounding, filter grounding, noise and interference suppression, and level reference.

2.3.7 Preventing Electromagnetic Interference

- Take interference prevention measures for the power supply system.
- Keep the equipment away from the grounding system or lightning protection grounding system of the power facility.
- Keep the equipment far away from high-frequency current equipment such as high-power radio transmitting stations and radar launchers.
- Take electromagnetic shielding measures when necessary.

2.3.8 Surge Protection

Although the equipment can guard against lightning strikes, strong lightning strikes may still damage the equipment. Take the following surge protection measures:

- Ensure that the grounding wire is in good contact with the ground.
- Ensure that the neutral point of the AC power socket is in good contact with the ground.
- Install a power arrester in front of the power input end to enhance surge protection for the power supply.

2.3.9 Installation Site

Regardless of whether the equipment is installed on a wall or a workbench, ensure that the following conditions are met:

- Maintain a proper clearance around the equipment for heat dissipation.
- Alternatively, place the equipment on a clean workbench. The installation of air conditioners is recommended in hot areas.

2.4 Tools

Table 2-4 Tools

Common Tools	Phillips screwdriver, cables, cage nuts, diagonal pliers, cable ties, and grounding wires
Dedicated Tools	Anti-ESD gloves, wire stripper, crimping pliers, RJ45 crimping pliers, and wire cutter
Meter	Multimeter

Note

The equipment is delivered without a toolkit. Prepare the preceding tools by yourself.

3 Installing the Switch

⚠ Caution

Before installing the equipment, ensure that guidelines and requirements in Chapter 2 have been met.

3.1 Before You Begin

- The installation site provides sufficient space for heat dissipation.
- The installation site meets the temperature and humidity requirements.
- The power supply is available at the installation site, and its current meets the requirements.
- The Ethernet cables have been deployed at the installation site.
- Locate the emergency power-off switch in the room before installation. In the case of an accident, cut off the power supply immediately.

3.2 Installing the Equipment

3.2.1 Wall Mount

i Note

- You need to prepare two screws (M3 x 6 mm Phillips pan head combination machine screws) and two plastic expansion anchors for wall mounting.
 - For wall mounting, install the equipment only on concrete or other non-flammable surfaces.
-

The steps for wall mounting a switch are as follows:

- (1) Drill two holes at suitable positions on the wall with a spacing of 112 mm (4.41 in.). The hole diameter and depth depend on the specifications of the purchased plastic expansion anchors.
- (2) Insert two plastic expansion anchors into the drilled holes.
- (3) Align the mounting holes on the switch with the holes on the wall, and tighten the screws, as shown in the following figure.

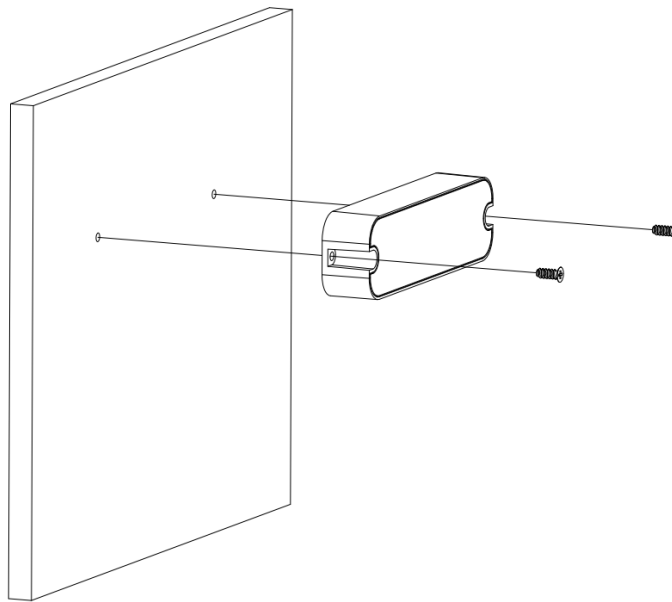
Figure 3-1 Mounting the Switch on a Wall

3.2.2 Workbench Mount

If wall mounting is not feasible, place the switch on a clean workbench and choose a location where it is unlikely to be touched, to ensure the safety and stability of the switch.

3.3 Verifying Installation

⚠ Caution

Please turn off the power to avoid personal injury and damage to components caused by incorrect connection.

- Verify that the cables including power cords are properly connected.
- Verify that cables connected to ports are routed indoors.
- Verify that the surge protection socket and Ethernet port arrester are installed, if outdoor cabling exists.
- Verify that there is a minimum clearance of 10 cm (3.94 in.) around the switch.

4 Commissioning

4.1 Startup Check

4.1.1 Checking before the Device is Powered on

- The power cable is correctly connected.
- The power supply voltage complies with the requirement of the switch.

4.1.2 Checking after Program Startup (Recommended)

After power-on, you are recommended to perform the following checks to ensure the normal operation of follow-up configurations.

- Check whether the status of the switch indicator is normal.
- Check whether the service interface forwards data normally.

5 Common Troubleshooting

5.1 General Troubleshooting Flowchart

Figure 5-1 General Troubleshooting Flowchart

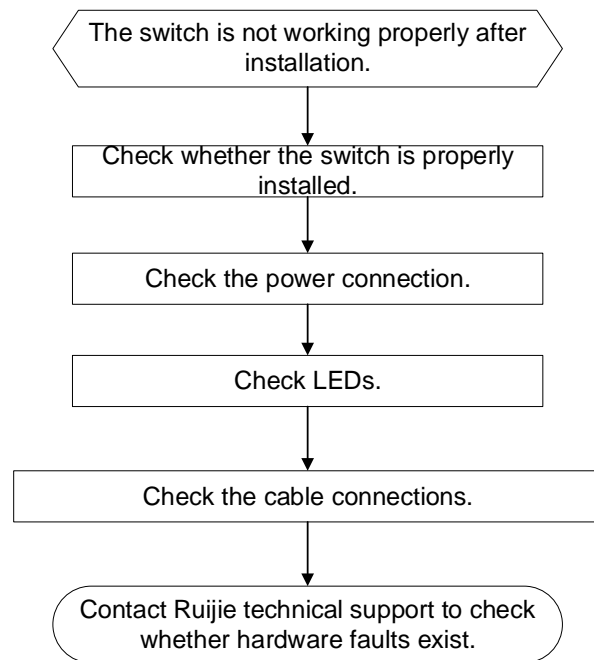

5.2 Common Faults

Table 5-1

Symptom	Possible Cause	Suggested Action
The system status LED is off after the switch is powered on.	The switch is not powered on. The Ethernet cable is loosely connected to the uplink port.	Check whether the Ethernet cable connected to the PoE In port is functioning properly and securely connected.

6 Appendix

6.1 Connectors and Media

10/100BASE-T Port

The 10/100BASE-T port supports auto-negotiation for 10 Mbps and 100 Mbps connections and also supports auto MDI/MDIX Crossover.

In addition to cables with the above-mentioned specifications, the 10/100BASE-T port can also be connected using 100-ohm CAT3, CAT4, and CAT5 cables at 10 Mbps or using 100-ohm CAT5 cables with a maximum distance of 100 m (328.08 ft.). The following table shows pin assignments for the 10/100BASE-T port.

Table 6-1 10/100BASE-T Pin Assignment

Pin	Socket	Plug
1	Input Receive Data+	Output Transmit Data+
2	Input Receive Data-	Output Transmit Data-
3	Output Transmit Data+	Input Receive Data+
6	Output Transmit Data-	Input Receive Data-
4, 5, 7, and 8	Not Used	Not Used

The following table shows wiring of straight-through and crossover cables for a 10/100BASE-T port.

Table 6-2 Twisted Pair Connections for the 10/100BASE-T Port

Straight-Through		Crossover	
Switch	Adapter	Switch	Switch
1 IRD+	1 OTD+	1 IRD+	1 IRD+
2 IRD-	2 OTD-	2 IRD-	2 IRD-
3 OTD+	3 IRD+	3 OTD+	3 OTD+
6 OTD-	6 IRD-	6 OTD-	6 OTD-

6.2 Lightning Protection

6.2.1 Installing the AC Power Arrester (Power Strip with Surge Protection)

When an alternating current (AC) power cord is introduced from outdoors and directly connected to the AC power port of the switch, the power port must be connected to an external power arrester to safeguard the switch against lightning strikes. The power arrester can be fixed on the rack, workbench, or wall in the equipment room by using cable ties and screws. AC power enters the power arrester before entering the switch.

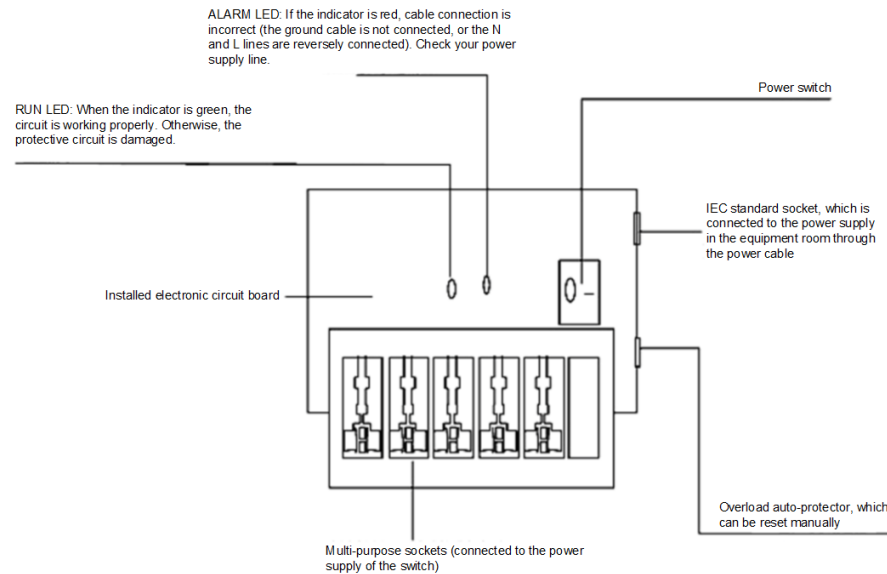
Figure 6-1 Power Arrester

Caution

The power arrester is not delivered with the equipment. Please purchase it based on actual requirements.

Precautions during the installation:

- Make sure that the PE terminal of the power arrester is well grounded.
- After the AC power plug of the switch is connected to the socket of the power arrester, the lightning protection function is implemented only if the running status LED is green and the alarm LED is off.
- If the alarm LED on the power arrester is red, check whether it is caused by a poor grounding connection or by the reversed connection of the neutral and live wires. The detection method is as follows: Use a multimeter to measure the polarity of the power arrester when the alarm LED is red. If the neutral wire is on the left and the live wire is on the right (facing the socket), the PE terminal of the power arrester is not grounded. If not, the polarity of the power arrester should be reversed. In this case, open the power arrester and reverse its polarity. If the alarm LED is still red, the PE terminal of the power arrester is not grounded.

6.2.2 Installing the Ethernet Port Arrester

Please connect an Ethernet port arrester to the switch to prevent the damage by lightning strikes before connecting an outdoor Ethernet cable to the switch.

- Tools: Phillips screwdriver or flat-blade screwdriver, multimeter, and diagonal pliers
- Installation steps
 - a Tear one side of the protective paper for the double-sided adhesive tape and paste the tape to the enclosure of the Ethernet port arrester. Tear the other side of the protective paper for the double-sided adhesive tape and paste the Ethernet port arrester to the switch enclosure. The paste position for the Ethernet port arrester should be as close to the grounding lug of the switch as possible.

- b Based on the distance between the grounding lug of the switch and the Ethernet port arrester, cut the grounding cable of the Ethernet port arrester and firmly tighten the grounding cable to the grounding lug of the switch.
- c Use a multimeter to check whether the grounding cable for the arrester is in good contact with the grounding lug and the enclosure of the switch.
- d Connect the Ethernet port arrester by using an adapter cable (note that the external Ethernet cable is connected to the IN end, while the adapter cable connected to the switch is connected to the OUT end) and check whether the module LED is normal.
- e Use a nylon cable tie to bind the cables.

Figure 6-2 Installing an Ethernet Port Arrester

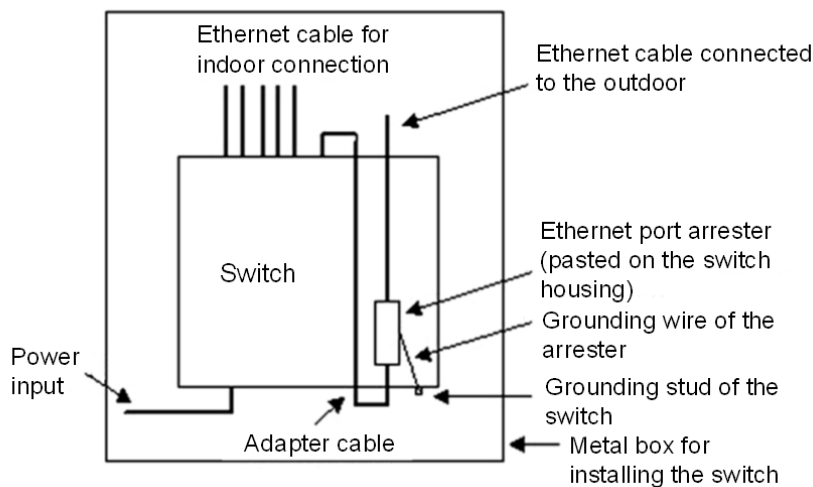

⚠ Caution

- The Ethernet port arrester is only for a 10 Mbps, 100 Mbps, or 1000 Mbps RJ45 port.
- The Ethernet port arrester is not delivered with the equipment. Please purchase it based on actual requirements. The user manual for Ethernet port arresters contains technical parameters and maintenance and installation instructions. Carefully read this manual during installation.

Pay attention to the following situations during the actual installation to avoid influencing the performance of an Ethernet port arrester:

- The arrester is incorrectly connected to the cables. Connect the external Ethernet cable to the IN end and connect the Ethernet port of the switch to the OUT end.
- The Ethernet port arrester is incorrectly grounded. The grounding cable of the arrester should be as short as possible to ensure that it is in good contact with the grounding lug of the switch. Use a multimeter to confirm the contact condition after grounding.
- Not all Ethernet ports are installed with Ethernet port arresters. If outdoor Ethernet cables connect the switch ports to the peer equipment, Ethernet port arresters need to be installed on all the ports for the purpose of lightning protection.

Contents

1 Overview	4
1.1 About the RG-ES205GC-V2	4
1.2 Equipment Appearance	4
1.2.1 Front Panel.....	4
1.2.2 Rear Panel	5
1.2.3 LEDs	6
1.3 Cooling.....	6
1.4 Technical Specifications	6
2 Preparing for Installation	10
2.1 Package Contents.....	10
2.2 Safety Guidelines.....	10
2.2.1 General Precautions	10
2.2.2 Chassis-Lifting Guidelines	10
2.2.3 Electricity Safety	11
2.2.4 Preventing ESD Damage.....	12
2.3 Site Requirements	12
2.3.1 Floor Loading	12
2.3.2 Airflow.....	12
2.3.3 Space	12
2.3.4 Temperature and Humidity.....	12
2.3.5 Cleanliness.....	12
2.3.6 Grounding	13
2.3.7 Preventing Electromagnetic Interference	14

2.3.8 Surge Protection	14
2.3.9 Installation Site.....	14
2.4 Tools	15
3 Installing the Switch	16
3.1 Before You Begin.....	16
3.2 Installing the Switch	16
3.2.1 Wall Mount	16
3.2.2 Workbench Mount.....	17
3.3 Grounding the Equipment.....	17
3.4 Connecting Cables.....	18
3.5 Bundling Cables.....	18
3.5.1 Precautions	18
3.5.2 Bundling Procedure	18
3.6 Verifying Installation.....	18
4 Commissioning.....	19
4.1 Power-On.....	19
4.2 Logging In to the Management Interface.....	19
5 Troubleshooting.....	20
5.1 General Troubleshooting Flowchart	20
5.2 Common Faults.....	20
6 Appendix.....	22
6.1 Connectors and Media.....	22
6.2 Lightning Protection	23
6.2.1 Installing the AC Power Arrester (Power Strip with Surge Protection)	23

6.2.2 Installing the Ethernet Port Arrester	24
6.3 Recommended Cabling	25
6.3.1 Requirement for the Minimum Bend Radius of Cables	26
6.3.2 Precautions for Cable Bundling	26
6.4 Site Selection	29

1 Overview

1.1 About the RG-ES205GC-V2

The RG-ES205GC-V2 Ethernet switch provides five 10/100/1000BASE-T ports, one Reset button, and several LEDs on the front panel, along with a 5 V DC power port and a grounding stud on the rear panel.

Figure 1-1 RG-ES205GC-V2 Appearance



Note

10/100/1000BASE-T port: Supports auto-negotiation at 10 Mbps, 100 Mbps, and 1000 Mbps.

1.2 Equipment Appearance

1.2.1 Front Panel

Figure 1-2 Front Panel of the RG-ES205GC-V2

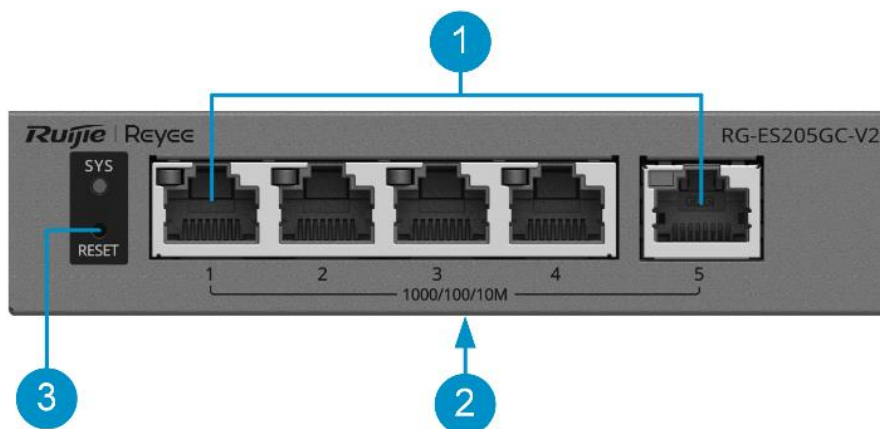

Table 1-1 Components on the Front Panel

No.	Component	Silkscreen	Description
1	RJ45 port	1–5	10/100/1000BASE-T ports
2	Nameplate	-	It is located at the bottom of the switch.
3	Reset button	RESET	<ul style="list-style-type: none"> ● Press and hold the button for less than 2 seconds. The switch is reset. ● Press and hold the button for 2–5 seconds. No action is performed. ● Press and hold the button for more than 5 seconds, and release the button until the system status LED starts blinking to restore factory settings and restart the switch.

Note

For details about LEDs on the front panel, see "LEDs."

1.2.2 Rear Panel

Figure 1-3 Rear Panel of the RG-ES205GC-V2

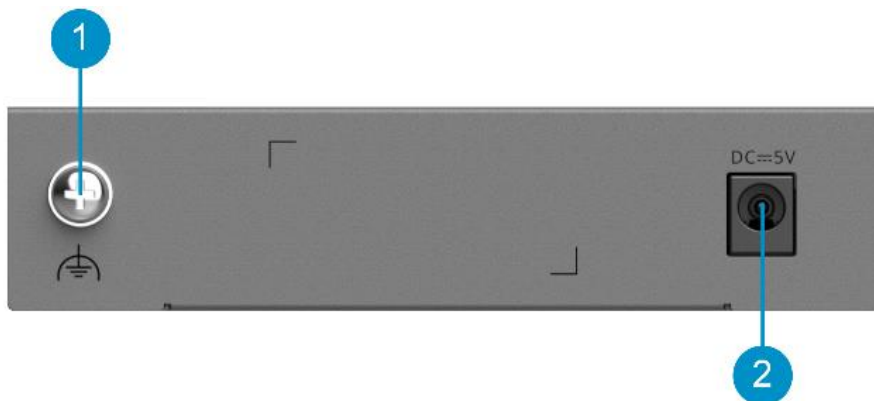

Table 1-2 Components on the Rear Panel

No.	Component	Description
1	Grounding stud	It is connected to a grounding wire.
2	DC power port	It is connected to a 5 V DC power source to supply power to the switch. The matching DC power connector has an outer diameter of 5.5 mm (0.22 in.), an inner diameter of 2.1 mm (0.08 in.), and a depth of 10 mm (0.39 in.).

1.2.3 LEDs

Figure 1-4 RG-ES205GC-V2 LEDs

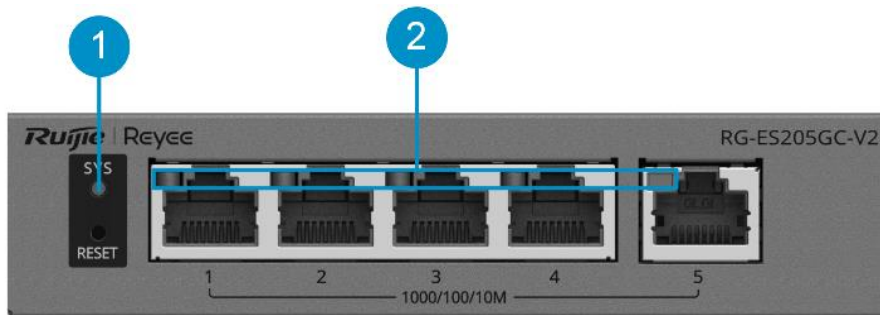

Table 1-3 LEDs

No.	Component	Silkscreen	Description
1	System status LED	SYS	<ul style="list-style-type: none"> ● Off: The switch is not powered on. ● Slow blinking green (0.5 Hz): The switch is operating normally but is not connected to Ruijie Cloud. ● Fast blinking green (10 Hz): The switch is upgrading or restarting, and is temporarily unavailable. ● Solid green: The switch is operating normally and connected to Ruijie Cloud. ● Slow blinking red (0.5 Hz): A loop occurs on the switch with loop guard enabled.
2	RJ45 port LED	-	<ul style="list-style-type: none"> ● Off: The port is not connected. ● Solid green: The port is operating at 1000 Mbps, 100 Mbps, or 10 Mbps, but is not receiving or sending data. ● Blinking green: The port is operating at 1000 Mbps, 100 Mbps, or 10 Mbps, and is receiving or sending data.

1.3 Cooling

The RG-ES205GC-V2 adopts fanless design and uses natural cooling. To ensure that the equipment works properly in the specified environment, a minimum clearance of 10 cm (3.94 in.) must be maintained around the equipment for air circulation and ventilation.

1.4 Technical Specifications

Warning

- This equipment is not suitable for use in locations where children are likely to be present.
- Operation of this equipment in a residential environment could cause radio interference.

Table 1-4 Technical Specifications

Parameter Type	Parameter Name	RG-ES205GC-V2
System Specifications	Forwarding rate	7.44 Mpps
	Switching capacity	10 Gbps(bit/s)
	Flash memory	8 MB
Port Specifications	Total number of RJ45 ports	5
	Number of 10/100/1000BASE-T ports	5
	Number of 1GE SFP ports	0
	Reset button	1
	LEDs	1 x system status LED 5 x Ethernet port LEDs
	DIP switch	NA
Power Supply and Consumption	Power supply	<ul style="list-style-type: none"> ● DC power adapter
	Power input	DC adapter: <ul style="list-style-type: none"> ● Rated input voltage: 100 V AC to 240 V AC, 50 Hz to 60 Hz ● Maximum input voltage: 90 V AC to 264 V AC, 47 Hz to 63 Hz ● Rated input current: 0.2 A Output : <ul style="list-style-type: none"> ● Rated output voltage: 5 V DC ● Maximum output current: 1 A
	Maximum power consumption	2.5 W
	Number of PoE Out ports	0
	PoE Out standard	NA
	PoE power pins	NA
	PoE budget per port	NA
PoE budget	NA	

Parameter Type	Parameter Name	RG-ES205GC-V2
Dimensions and Weight	Product dimensions (W x D x H)	121mm x 62mm x 28mm (4.76 in. x 2.44 in. x 1.10 in.)
	Weight	0.19 kg (0.42 lbs) (without packaging materials)
	Shipping weight	0.36 kg (0.79 lbs)
	Casing	Metal
Interface	EEE	Yes
Environment and Reliability	Mounting options	Wall/Desk
	Hot swapping of cables	Hot swapping supported by the service port and power connector
	Fan	Fanless design
	Cooling	Natural cooling
	MTBF	200,000 hours
	ESD protection	Air discharge: 8 kV Contact discharge: 6 kV
	Surge protection	Service port: ± 6 kV for common mode Power connector: ± 4 kV for common mode and ± 2 kV for differential mode
	Operating temperature	0°C to +40°C (32°F to 104°F)
	Storage temperature	-40°C to +70°C (-40°F to +158°F)
	Operating humidity	10% RH to 90% RH (non-condensing)
	Storage humidity	5% RH to 95% RH (non-condensing)
Altitude	-500 m to +5,000 m (-1,640.42 ft. to +16,404.20 ft.)	
Certification and Regulatory Compliance	EMC	EN 55032 EN 61000-3-2 EN 61000-3-3 EN 55035 EN 300 386

Parameter Type	Parameter Name	RG-ES205GC-V2
	Safety compliance	EN 62368-1 IEC 62368-1
	Certification	CE,CB

2 Preparing for Installation

2.1 Package Contents

Table 2-1 Package Contents

No.	Item	Quantity
1	RG-ES205GC-V2 switch	1
2	User Manual	1
3	Warranty Card	1
4	Power adapter	1

Note

The package contents are subject to the purchase contract, and actual delivery may vary. Please check the items carefully against the package contents or purchase contract. If you have any questions, please contact the distributor.

2.2 Safety Guidelines

Note

- To avoid personal injury or equipment damage, review the safety guidelines in this chapter before you begin the installation.
- The following safety guidelines may not include all the potentially hazardous situations.

2.2.1 General Precautions

- Never operate the equipment in a wet environment, and avoid any liquids inside it. Keep the chassis clean and dust-free.
- Keep the equipment away from heat sources.
- Keep the equipment away from walk areas.
- During installation and maintenance, do not wear loose clothing or ornament that may get caught in the chassis.
- Keep tools and accessories away from walk areas.

2.2.2 Chassis-Lifting Guidelines

- Avoid moving the equipment frequently.
- Turn off all power supplies and disconnect all cables before lifting or moving the equipment.

2.2.3 Electricity Safety

Warning

- Any deviation from standard or improper electrical operations can result in accidents such as fires or electric shocks, potentially causing severe or even fatal harm to both individuals and equipment.
 - Direct or indirect touch through a wet object on high-voltage and mains supply can bring a fatal danger.
-
- Always observe the local regulations and standards. Only qualified personnel should be allowed to operate the equipment.
 - Carefully check the work area for potential hazards, including ungrounded power system, absent safety grounds, and damp floors.
 - Locate the emergency power-off switch in the room before installation. In the case of an accident, cut off the power supply immediately.
 - Never assume that power is connected to or disconnected from a circuit. Always check.
 - Select the right leakage protector (also called "leakage current switch" or "leakage current breaker") for the power supply system. This equipment automatically disconnects the power supply in the event of leakage and the risk of electric shock. A leakage protector should meet the following requirements:
 - The rated leakage action current of each leakage protector must be at least twice the total maximum leakage current of all connected power supplies.

Example:

If a system has 16 identical power supplies, each with a maximum leakage current of 3.5 mA:

Total leakage current = $16 \times 3.5 \text{ mA} = 56 \text{ mA}$

For a 30 mA leakage protector:

Maximum number of power supplies per protector = $30 \text{ mA} / 2 / 3.5 \text{ mA} \approx 4$

Therefore, only four power supplies can be connected to one 30 mA leakage protector.

To support 16 power supplies, at least four 30 mA leakage protectors are required.

Always ensure:

Rated leakage operating current/2 > Total maximum leakage current of connected power supplies

- The rated leakage non-action current of a leakage protector should be 50% of the leakage action current. If the non-action current value is too small, the high sensitivity level can cause the circuit to break, leading to power cutoff and service interruption, even if the leakage current value is normal.

For example, if a leakage protector has a rated leakage action current of 30 mA, the rated leakage non-action current should be 15 mA. The leakage protector will not activate unless the leakage current exceeds 15 mA.

Caution

- To ensure personal safety, each leakage protector in the system must have a rated leakage action current equal to or below 30 mA, which is the recognized safety threshold for human body current. If the total leakage current of the system exceeds twice the 30 mA limit, the system must be equipped with two or more leakage protectors to maintain safety.
 - The leakage current values vary with equipment. For the leakage current value of each equipment model, see "Technical Specifications."
-

2.2.4 Preventing ESD Damage

- Ensure that the chassis is connected to earth ground.
- Keep the site as dust free as possible.
- Maintain appropriate humidity conditions.
- Before installing any pluggable modules, wear an anti-ESD wrist strap and make sure that it is properly grounded.
- Avoid contact between the printed circuit boards and clothing. The anti-ESD wrist strap only protects the printed circuit boards from ESD voltages on the body. ESD voltages on clothing can still cause damage.

2.3 Site Requirements

The equipment must be installed indoors for normal operation and prolonged service life.

The installation site must meet the following requirements.

2.3.1 Floor Loading

Assess the combined weight of the equipment and its accessories, such as chassis and power modules, and verify that the floor under the rack can bear the weight.

2.3.2 Airflow

The equipment adopts natural cooling. Reserve a sufficient clearance around the equipment to ensure proper ventilation.

2.3.3 Space

Do not install the equipment against a wall. Instead, maintain a minimum clearance of 10 cm (3.94 in.) around the equipment for heat dissipation and equipment maintenance.

2.3.4 Temperature and Humidity

To ensure the normal operation and a prolonged service life of the equipment, maintain an appropriate temperature and humidity in the installation environment.

Prolonged exposure to inappropriate temperature and humidity conditions can cause damage to the equipment.

- In an environment with high relative humidity, insulating materials are prone to poor insulation or even electricity leakage.
- In an environment with low relative humidity, insulating gaskets may shrink, resulting in screw loosening.
- In a dry environment, static electricity is more likely to occur, posing a risk to the internal circuits of equipment.
- A high temperature can accelerate the aging process of insulation materials, greatly reducing the availability of the equipment and severely affecting its service life.

2.3.5 Cleanliness

Dust poses a significant hazard to the equipment. Dust on the enclosure causes electrostatic adhesion, leading to poor contact of the metallic joints. Electrostatic adhesion is more likely to occur in an indoor environment with

relatively low humidity, not only affecting the service life of the equipment, but also causing communication faults. The following table lists the requirements for dust concentration and particle size in the equipment room.

Table 2-2 Requirements for Dust

Particle Diameter	Unit	Concentration
≥ 0.5 μm	Particles/m ³	≤ 3.5 × 10 ⁶
≥ 5 μm	Particles/m ³	≤ 3.5 × 10 ⁶

Apart from dust, there are also requirements on the salt, acid, and sulfide in the air of the equipment room. These harmful substances will accelerate metal corrosion and component aging. Therefore, the equipment room should be properly protected against harmful gases, such as sulfur dioxide, hydrogen sulfide, nitrogen dioxide, and chlorine gas. The following table lists the limits on harmful gases.

Table 2-3 Requirements for Gases

Gas	Average (mg/m ³)	Maximum (mg/m ³)
Sulfur dioxide (SO ₂)	0.3	1.0
Hydrogen sulfide (H ₂ S)	0.1	0.5
Nitrogen dioxide (NO ₂)	0.5	1.0
Chlorine gas (Cl ₂)	0.1	0.3

 **Note**

Average refers to the average value of harmful gases measured in a week. **Maximum** refers to the upper limit of harmful gases measured in a week for up to 30 minutes every day.

2.3.6 Grounding

A proper grounding system is crucial for ensuring stable and reliable operation, as well as preventing lightning strikes and interference. Carefully check the grounding conditions at the installation site according to the grounding requirements, and complete grounding properly based on the site situation.

- **Safety Grounding**

Ensure that the power distribution system is securely grounded if the equipment uses the AC power supply. Otherwise, electric shocks may occur when the insulation resistance between the power module and the chassis decreases.

 **Caution**

- The building should provide a protective ground connection to ensure that the equipment is connected to a protective ground.

- Verify that the AC socket is reliably connected to the protective grounding system of the building. If not, a protective grounding wire should be used to connect the protective grounding lug of the AC socket to the protective grounding system of the building.
-

- **Lightning Grounding**

The lightning protection system is an independent system composed of a lightning rod, a downlead conductor, and a connector connected to the grounding system. The grounding system is typically used for power reference grounding and safety grounding. Lightning grounding is required only for facilities, and is not required for the equipment.

- **EMC Grounding**

Electromagnetic compatibility (EMC) grounding includes shielded grounding, filter grounding, noise and interference suppression, and level reference.

2.3.7 Preventing Electromagnetic Interference

- Take interference prevention measures for the power supply system.
- Keep the equipment away from the grounding system or lightning protection grounding system of the power facility.
- Keep the equipment far away from high-frequency current equipment such as high-power radio transmitting stations and radar launchers.
- Take electromagnetic shielding measures when necessary.

2.3.8 Surge Protection

Although the equipment can guard against lightning strikes, strong lightning strikes may still damage the equipment. Take the following surge protection measures:

- Ensure that the grounding wire is in good contact with the ground.
- Ensure that the neutral point of the AC power socket is in good contact with the ground.
- Install a power arrester in front of the power input end to enhance surge protection for the power supply.

2.3.9 Installation Site

Regardless of whether the equipment is installed on a wall or a workbench, ensure that the following conditions are met:

- Maintain a proper clearance around the equipment for heat dissipation.
- Alternatively, place the equipment on a clean workbench. The installation of air conditioners is recommended in hot areas.

2.4 Tools

Table 2-4 Tools

Common Tools	Phillips screwdriver, cables, cage nuts, diagonal pliers, cable ties, and grounding wires
Dedicated Tools	Anti-ESD gloves, wire stripper, crimping pliers, RJ45 crimping pliers, and wire cutter
Meter	Multimeter

 **Note**

The equipment is delivered without a toolkit. Prepare the preceding tools by yourself.

3 Installing the Switch

⚠ Caution

Before installing the equipment, ensure that guidelines and requirements in Chapter 2 have been met.

3.1 Before You Begin

- The installation site provides sufficient space for heat dissipation.
- The installation site meets the temperature and humidity requirements.
- The power supply is available at the installation site, and its current meets the requirements.
- The Ethernet cables have been deployed at the installation site.
- Locate the emergency power-off switch in the room before installation. In the case of an accident, cut off the power supply immediately.

3.2 Installing the Switch

3.2.1 Wall Mount

i Note

- You need to prepare two M3 screws and two plastic expansion anchors for wall mounting.
 - For wall mounting, install the equipment only on concrete or other non-flammable surfaces.
-

The steps for wall mounting a switch are as follows:

- (1) Drill two holes at suitable positions on the wall with a spacing of 67 mm (2.64 in.). The hole diameter and depth depend on the specifications of the purchased plastic expansion anchors.
- (2) Insert two plastic expansion anchors into the drilled holes, and then screw two M3 screws into the plastic expansion anchors.

i Note

- Ensure that the distance between the inner side of the screw heads and the outer edge of the plastic expansion anchors is at least 2.5 mm (0.1 in.) to securely mount the equipment onto the screws.
 - The equipment appearance shown in the installation diagram is for reference only.
-

- (3) Mount the equipment on the two M3 screws, as shown in the following figure.

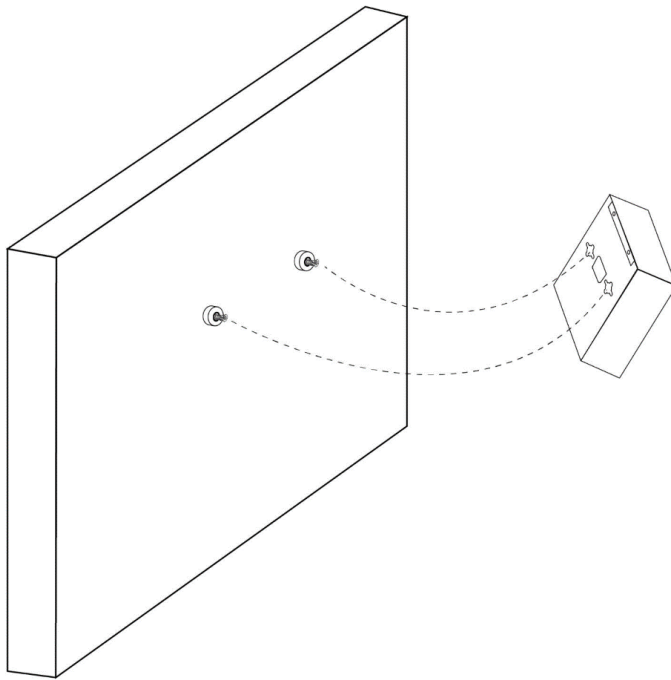
Figure 3-1 Mounting the Switch on a Wall

3.2.2 Workbench Mount

If wall mounting is not feasible, place the switch on a clean workbench and choose a location where it is unlikely to be touched, to ensure the safety and stability of the switch.

3.3 Grounding the Equipment

Note

- If the equipment is installed on a workbench, connect the grounding wire to the nearest grounding bar or grounding point based on the onsite situation.
 - The grounding wire is not delivered with the equipment and needs to be purchased by the customer.
-

The equipment has a grounding stud on the rear panel. You are advised to connect the system grounding wire to it before using the equipment.

- (1) Purchase a grounding wire and connect one end to the grounding stud at the rear of the equipment.
 - (2) Connect the other end of the grounding wire to the nearest grounding bar or grounding point.
-

Caution

- To avoid personal injury and equipment damage, connect the switch to earth ground properly. The grounding resistance between the chassis and the ground should be less than 1 ohm.
 - The O&M personnel should verify whether the AC socket is reliably connected to the protective ground of the building. If not, the O&M personnel should use a protective grounding wire to connect the protective grounding lug of the AC socket to the protective ground of the building.
 - The power socket should be installed near the equipment and easily accessible.
 - During the equipment installation, connect the grounding wire first and disconnect it last.
-

- The sectional area of a grounding wire should be determined according to the possible maximum current. Grounding wires with good conductors should be used.
 - Do not use bare wires.
-

3.4 Connecting Cables

Caution

All cables must be routed indoors. Take surge protection measures if they need to be routed outdoors.

After the switch is installed, connect the switch to other equipment according to the following steps:

- (1) Connect the power cord delivered with the switch to the power strip.
- (2) Connect the RJ45 connector of a twisted pair to an Ethernet port on the switch, and the other end to downlink equipment.

3.5 Bundling Cables

3.5.1 Precautions

- Bundle the power cord and other cables in an esthetically pleasing way.
- Do not bind twisted pairs too tightly, as this may compromise their service life and transmission performance.

3.5.2 Bundling Procedure

- (1) Bind the drooping part of the twisted pairs, and lead them to both sides of the chassis for convenience.
- (2) Bind the power cord closely along the bottom of the chassis, in a straight line wherever possible.

3.6 Verifying Installation

Caution

Please turn off the power to avoid personal injury and damage to components caused by incorrect connection.

- Verify that the grounding wire is connected.
- Verify that the cables including power cords are properly connected.
- Verify that cables connected to ports are routed indoors.
- Verify that the surge protection socket and Ethernet port arrester are installed, if outdoor cabling exists.
- Verify that there is a minimum clearance of 10 cm (3.94 in.) around the switch.

4 Commissioning

4.1 Power-On

- (1) Checklist Before Power-on
 - The switch is properly grounded.
 - The power cord is properly connected.
 - The power supply voltage meets the requirement of the switch.
- (2) Checklist After Power-on (Recommended)
 - The switch LEDs are in the normal state.
 - Service ports can forward data properly.

4.2 Logging In to the Management Interface

- (1) Connect a PC to an Ethernet port on the switch through an Ethernet cable.
- (2) Set the IP address of the PC to 10.44.77.XXX (Range: 1–254, excluding 200).

Figure 4-1 Changing the IP Address

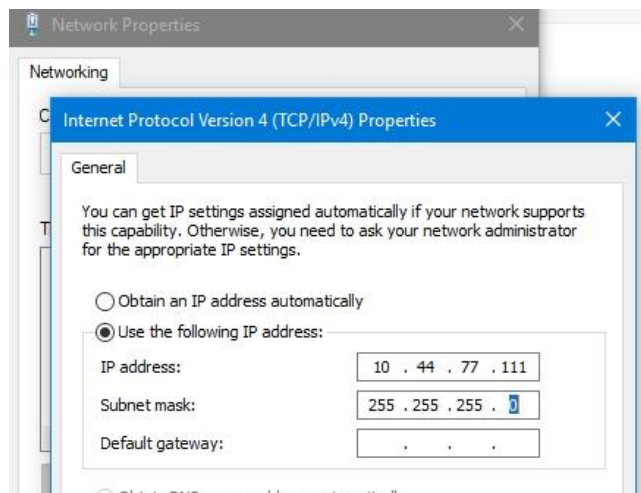

- (3) Open a browser, enter 10.44.77.200 in the address bar, and press Enter. On the login page, set a password and log in.
- (4) Perform equipment commissioning and configuration based on service requirements.

Note

For security purposes, you are advised to change the password regularly.

5 Troubleshooting

5.1 General Troubleshooting Flowchart

Note

You can determine whether each checking item in the process is normal based on the information provided in the previous chapters "Overview" and "Installing the Switch."

Figure 5-1 General Troubleshooting Flowchart

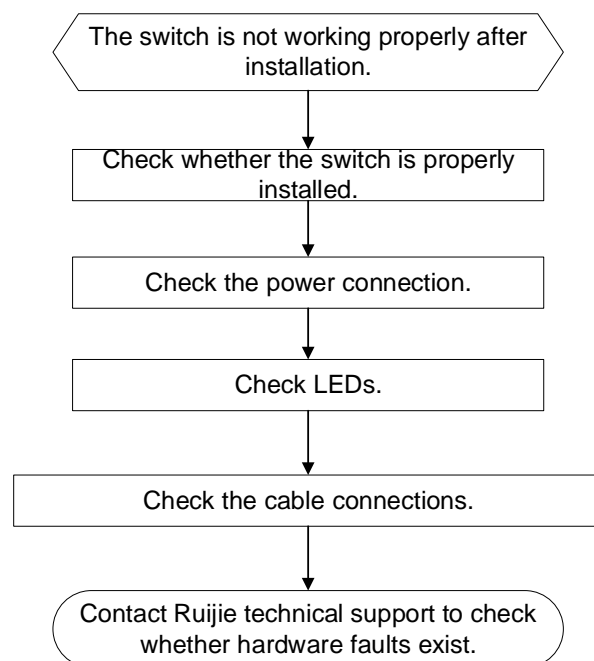

5.2 Common Faults

Table 5-1 Common Faults and Troubleshooting

Symptom	Possible Cause	Suggested Action
The system status LED is off after the switch is powered on.	No power is supplied to the switch or the power cord is loosely connected.	Check whether the power socket in the equipment room is normal and whether the power cord is loosely connected to the switch.
An RJ45 port is disconnected or a frame	The twisted pair is not connected properly.	Replace the twisted pair.

Symptom	Possible Cause	Suggested Action
sending/receiving error occurs.	The cable length exceeds 100 m (328.08 ft.).	Use an optical cable for data transmission or connect to an intermediate switch for relay.
	The port is specially configured and does not work in the same mode as that of the interconnected switch.	Check whether the port is configured to work in the same mode as that of the interconnected switch.
The login password cannot be retrieved.	The password is forgotten, and the equipment is not connected to the network or Ruijie Cloud.	Press and hold the Reset button to restore to factory settings.
	If the equipment is connected to Ruijie Cloud or a network, its login password is updated to the project or global management password.	If the equipment is connected to the cloud, log in using the project management password. If the equipment is connected to a network, log in using the global management password.

6 Appendix

6.1 Connectors and Media

10/100/1000BASE-T Port

The 10/100/1000BASE-T port supports auto-negotiation for 10 Mbps, 100 Mbps, and 1000 Mbps connections and also supports auto MDI/MDIX Crossover.

Compliant with IEEE 802.3ab, a 1000BASE-T port connects to a 100-ohm Category 5 (CAT5) or Category 5 Enhanced (CAT5e) Unshielded Twisted Pair (UTP), or recommended Shielded Twisted Pair (STP) cable with a maximum distance of 100 m (328.08 ft.).

The 1000BASE-T port requires that all four pairs of wires be connected for data transmission. [Figure 6-1](#) shows twisted pair connections for the 1000BASE-T port.

Figure 6-1 Twisted Pair Connections for a 1000BASE-T Port

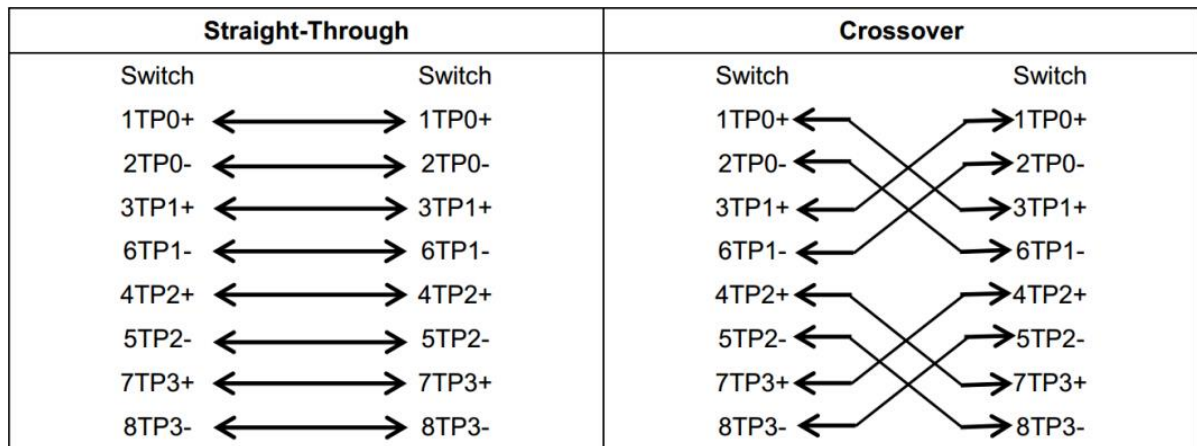

In addition to cables with the above-mentioned specifications, the 10/100BASE-T port can also be connected using 100-ohm CAT3, CAT4, and CAT5 cables at 10 Mbps or using 100-ohm CAT5 cables with a maximum distance of 100 m (328.08 ft.). The following table shows pin assignments for a 10/100BASE-T port.

Table 6-1 10/100BASE-T Pin Assignment

Pin	Socket	Plug
1	Input Receive Data+	Output Transmit Data+
2	Input Receive Data-	Output Transmit Data-
3	Output Transmit Data+	Input Receive Data+
6	Output Transmit Data-	Input Receive Data-
4, 5, 7, and 8	Not Used	Not Used

The following table shows wiring of straight-through and crossover cables for a 10/100BASE-T port.

Figure 6-2 Twisted Pair Connections for a 10/100BASE-T Port

Straight-Through		Crossover	
Switch	Adapter	Switch	Switch
1 IRD+	1 OTD+	1 IRD+	1 OTD+
2 IRD-	2 OTD-	2 IRD-	2 OTD-
3 OTD+	3 IRD+	3 OTD+	3 IRD+
6 OTD-	6 IRD-	6 OTD-	6 IRD+

6.2 Lightning Protection

6.2.1 Installing the AC Power Arrester (Power Strip with Surge Protection)

When an alternating current (AC) power cord is introduced from outdoors and directly connected to the AC power port of the switch, the power port must be connected to an external power arrester to safeguard the switch against lightning strikes. The power arrester can be fixed on the rack, workbench, or wall in the equipment room by using cable ties and screws. AC power enters the power arrester before entering the switch.

Figure 6-3 Power Arrester

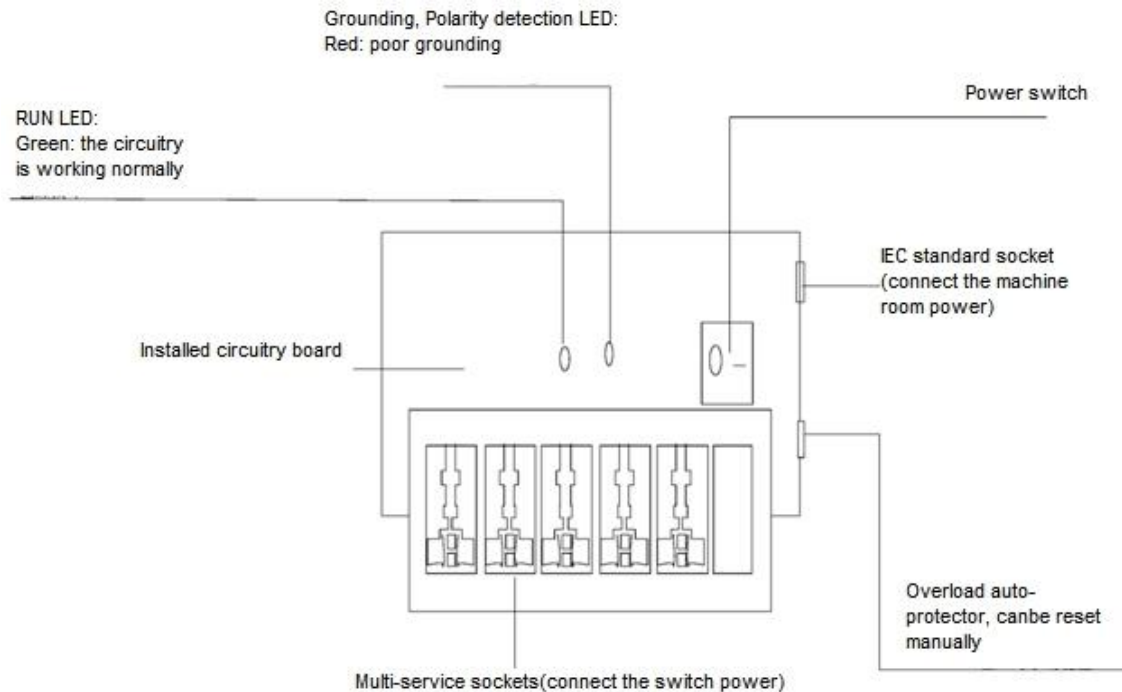

⚠ Caution

The power arrester is not delivered with the equipment. Please purchase it based on actual requirements.

Precautions during the installation:

- Make sure that the PE terminal of the power arrester is well grounded.

- After the AC power plug of the switch is connected to the socket of the power arrester, the lightning protection function is implemented only if the running status LED is green and the alarm LED is off.
- If the alarm LED on the power arrester is red, check whether it is caused by a poor grounding connection or by the reversed connection of the neutral and live wires. The detection method is as follows: Use a multimeter to measure the polarity of the power arrester when the alarm LED is red. If the neutral wire is on the left and the live wire is on the right (facing the socket), the PE terminal of the power arrester is not grounded. If not, the polarity of the power arrester should be reversed. In this case, open the power arrester and reverse its polarity. If the alarm LED is still red, the PE terminal of the power arrester is not grounded.

6.2.2 Installing the Ethernet Port Arrester

Please connect an Ethernet port arrester to the switch to prevent the damage by lightning strikes before connecting an outdoor Ethernet cable to the switch.

- Tools: Phillips screwdriver or flat-blade screwdriver, multimeter, and diagonal pliers
- Installation steps
 - a Tear one side of the protective paper for the double-sided adhesive tape and paste the tape to the enclosure of the Ethernet port arrester. Tear the other side of the protective paper for the double-sided adhesive tape and paste the Ethernet port arrester to the switch enclosure. The paste position for the Ethernet port arrester should be as close to the grounding lug of the switch as possible.
 - b Based on the distance between the grounding lug of the switch and the Ethernet port arrester, cut the grounding cable of the Ethernet port arrester and firmly tighten the grounding cable to the grounding lug of the switch.
 - c Use a multimeter to check whether the grounding cable for the arrester is in good contact with the grounding lug and the enclosure of the switch.
 - d Connect the Ethernet port arrester by using an adapter cable (note that the external Ethernet cable is connected to the IN end, while the adapter cable connected to the switch is connected to the OUT end) and check whether the module LED is normal.
 - e Use a nylon cable tie to bind the cables.

Figure 6-4 Installing an Ethernet Port Arrester

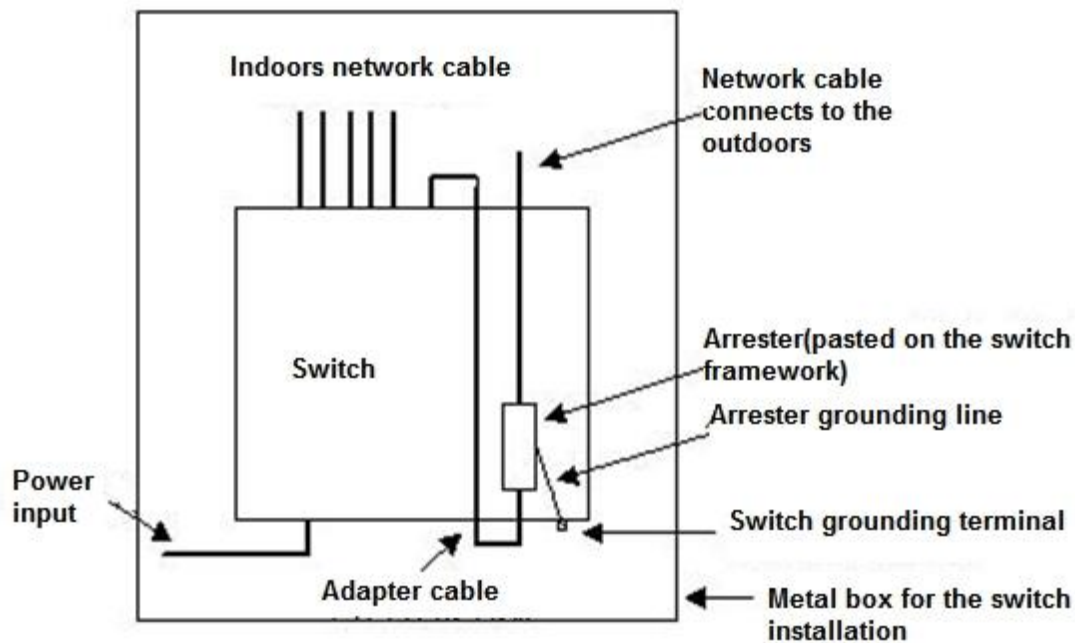

⚠ Caution

- The Ethernet port arrester is only for a 10 Mbps, 100 Mbps, or 1000 Mbps RJ45 port.
- The Ethernet port arrester is not delivered with the equipment. Please purchase it based on actual requirements. The user manual for Ethernet port arresters contains technical parameters and maintenance and installation instructions. Carefully read this manual during installation.

Pay attention to the following situations during the actual installation to avoid influencing the performance of an Ethernet port arrester:

- The arrester is incorrectly connected to the cables. Connect the external Ethernet cable to the IN end and connect the Ethernet port of the switch to the OUT end.
- The Ethernet port arrester is incorrectly grounded. The grounding cable of the arrester should be as short as possible to ensure that it is in good contact with the grounding lug of the switch. Use a multimeter to confirm the contact condition after grounding.
- Not all Ethernet ports are installed with Ethernet port arresters. If outdoor Ethernet cables connect the switch ports to the peer equipment, Ethernet port arresters need to be installed on all the ports for the purpose of lightning protection.

6.3 Recommended Cabling

When the switch is installed in a standard 19-inch cabinet, secure the cables around the cable management brackets. Top cabling or bottom cabling is adopted according to the actual situation in the equipment room. All adapted connectors should be placed at the bottom of the rack in an orderly manner instead of outside the rack that is easy to touch. Power cords are routed beside the rack. Top cabling or bottom cabling is adopted according

to the actual situation in the equipment room, such as the positions of the DC power distribution box, AC socket, or lightning protection box.

6.3.1 Requirement for the Minimum Bend Radius of Cables

- The bend radius of a fixed power cord, Ethernet cable, and flat cable should be over five times greater than their respective external diameters. The bend radius of these cables that are often bent or plugged should be over seven times greater than their respective external diameters.
- The bend radius of a fixed common coaxial cable should be over seven times greater than its external diameter. The bend radius of these cables that are often bent or plugged should be over 10 times greater than their respective external diameters.
- The minimum bend radius of a high-speed cable, such as an SFP+ cable, should be 5 times the overall diameter of the cable. If the cable is constantly bent, plugged or unplugged, the bend radius should be 10 times the overall diameter.
- The minimum bend radius of optical cables should meet the following requirements.
 - The diameter of the optical cable tray should be no less than 25 times greater than that of the optical cable.
 - When an optical cable is moved, its bend radius should be no less than 20 times greater than its diameter.
 - During cabling of an optical cable, its bend radius should be no less than 10 times greater than its diameter.

6.3.2 Precautions for Cable Bundling

- Before cables are bundled, mark labels and stick the labels to cables wherever appropriate.
- Cables should be neatly and properly bundled in the rack without twisting or bending, as shown in [Figure 6-5](#).

Figure 6-5 Bundling Cables (1)

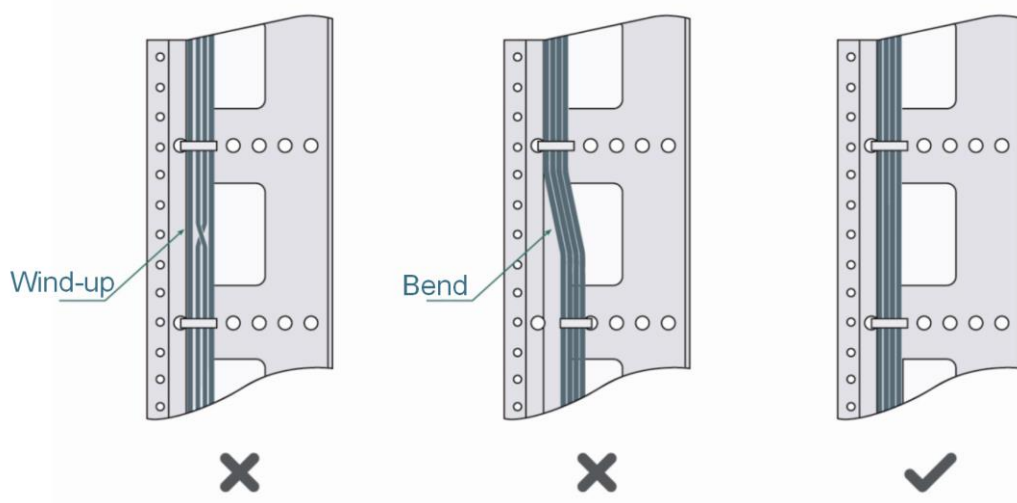

- Cables of different types (such as power cords, signal cables, and grounding wires) should be separated in cabling and bundling. Mixed bundling is not allowed. When they are close to each other, you are advised to

adopt crossover cabling. In the case of parallel cabling, maintain a minimum distance of 30 mm (1.18 in.) between power cords and signal cables.

- The cable management brackets and cabling troughs inside and outside the rack should be smooth without sharp corners.
- The metal holes traversed by cables should have a smooth and fully rounded surface or an insulated lining.
- Use cable ties to bundle cables properly. Please do not connect two or more cable ties to bundle cables.
- After bundling up cables with cable ties, cut off the remaining part. The cut should be smooth and trim without sharp corners, as shown in [Figure 6-6](#).

Figure 6-6 Bundling Cables (2)

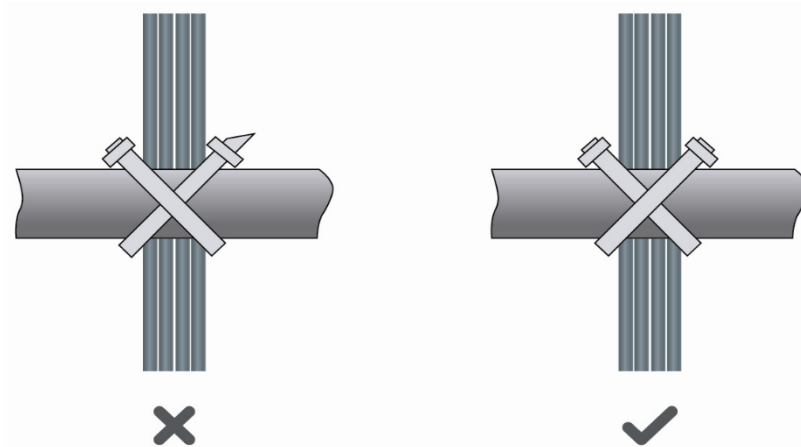

- When cables need to be bent, bundle them first but do not tie cables within the bend. Otherwise, stress may be generated on the cables and cause the wires inside to break, as shown in [Figure 6-7](#).

Figure 6-7 Bundling Cables (3)

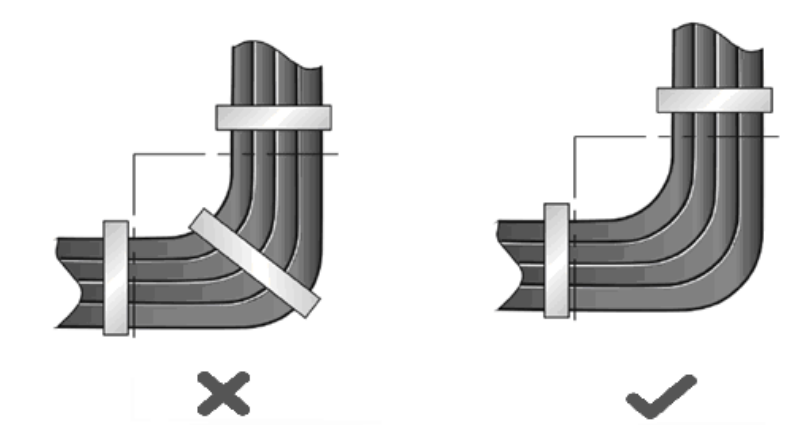

- Cables not to be assembled or the remaining parts of cables should be folded and placed in a proper position of the rack or cable management trough. The proper position refers to a position that does not affect the equipment running or damage the equipment or cables.
- Power cords must not be bundled on the guide rails of moving parts.
- The power cords connecting moving parts such as door grounding wires should be reserved with some

excess after being assembled to avoid suffering tension or stress. When a moving part reaches the installation position, the remaining cable part should not touch heat sources, sharp corners, or sharp edges. If heat sources must be touched, high-temperature cables should be used.

- When using screw threads to secure a cable lug, ensure that the bolt or screw is properly tightened and take measures to prevent it from loosening, as shown in [Figure 6-8](#).

Figure 6-8 Fastening Cables

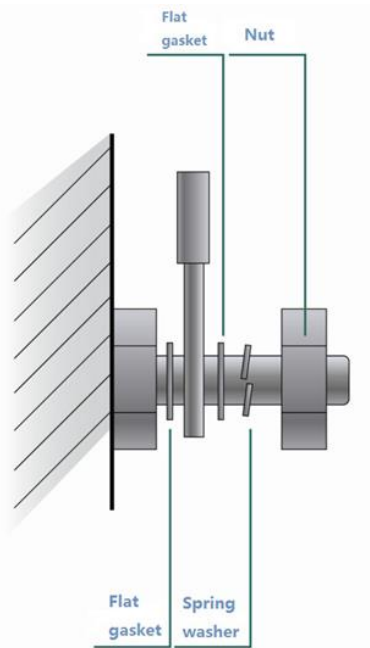

- Hard power cords should be secured near the cable termination area to prevent stress on the cable termination area and cables.
- Do not use tapping screws to secure cable lugs.
- Power cords of the same type and in the same cabling direction should be bundled up into cable bunches, with cables in cable bunches clean and straight.
- Bundle cables by using cable ties according to the following table.

Cable Bunch Diameter	Bundling Spacing
10 mm (0.39 in.)	80–150 mm (3.15–5.91 in.)
10–30 mm (0.39–1.18 in.)	150–200 mm (5.91–7.87 in.)
30 mm (1.18 in.)	200–300 mm (7.87–11.81 in.)

- Do not tie cables or bundles in a knot.
- For wiring terminal blocks (such as circuit breakers) with cord end terminals, the metal part of the cord end terminal should not be exposed outside the terminal block when assembled.

6.4 Site Selection

- The equipment room should be at least 5 km (3.11 miles) away from heavy pollution sources, such as smelters, coal mines, and thermal power plants. The equipment room should be at least 3.7 km (2.30 miles) away from medium pollution sources, such as the chemical factory, rubber factory, and electroplating factory. The equipment room should be at least 2 km (1.24 miles) away from light pollution sources, such as the food factory and leather plant. If the pollution source is unavoidable, the equipment room should be located on the windward side of the pollution source perennially with advanced protection.
- The equipment room should be at least 3.7 km (2.30 miles) away from the sea or salt lake. Otherwise, the equipment room must be sealed, with an air conditioner installed for temperature control. Saline soil cannot be used for construction. Otherwise, you should select equipment with advanced protection against severe environments.
- Do not build the equipment room in the proximity of livestock farms. Otherwise, the equipment room should be located on the windward side of the pollution source perennially. The previous livestock house or fertilizer warehouse cannot be used as the equipment room.
- The equipment room should be firm enough to withstand severe weather conditions such as windstorms, heavy rain, and dense dust. If the dust is unavoidable, keep the door and window away from the pollution source.
- The equipment falls into Class A. Therefore, the equipment room should be located away from the residential area. Otherwise, the equipment room should meet construction specifications to avoid noise and radio interference.
- Make sure the air vent of the equipment room is away from the sewage pipe, septic tank, and sewage treatment tank. Keep the equipment room under positive pressure to prevent corrosive gas from entering the equipment room to corrode components and circuit boards.
- Keep the equipment room away from industrial boilers and heating boilers.
- The equipment room should be on the second floor or higher. Otherwise, the equipment room floor should be 600 mm (23.62 in.) higher than the highest flood level ever recorded.
- Make sure no cracks or holes exist in the wall and floor. If there are cable entries in the wall or window, take proper sealing measures. Ensure that the wall is flat, wear-resistant, and dust-free, meeting standards for flame resistance, soundproofing, heat absorption, dust reduction, and electromagnetic shielding.
- Keep the door and the window closed to make the equipment room sealed.
- You are advised to use the steel door for soundproofing.
- Do not use sulfur-containing materials.
- Keep the air conditioner from blowing wind straight toward the equipment or blowing water drops from the window or air vent toward the equipment.

Contents

1 Overview	4
1.1 About the RG-ES207GS-AC-OD.....	4
1.2 Equipment Appearance	5
1.2.1 Front Panel.....	5
1.2.2 Bottom Cover Removal.....	6
1.2.3 Rear Panel	7
1.3 Cooling.....	8
1.4 Technical Specifications	8
2 Preparing for Installation	11
2.1 Package Contents.....	11
2.2 Safety Guidelines.....	11
2.2.1 General Precautions	11
2.2.2 Chassis-Lifting Guidelines	12
2.2.3 Electricity Safety	12
2.2.4 Preventing ESD Damage.....	13
2.2.5 Laser Safety	13
2.3 Site Requirements	14
2.3.1 Floor Loading	14
2.3.2 Airflow.....	14
2.3.3 Temperature and Humidity.....	14
2.3.4 Waterproof	14
2.3.5 Grounding	14
2.3.6 Preventing Electromagnetic Interference	14

2.3.7 Surge Protection	15
2.4 Tools	15
3 Installing the Switch	16
3.1 Installation Procedure	16
3.2 Before You Begin.....	16
3.3 Installation Precautions.....	17
3.4 Making Cables	17
3.5 Connecting Cables to the Equipment.....	18
3.6 Installing the Equipment	22
3.6.1 Pole Mount	22
3.6.2 Wall Mount	23
3.7 Bundling Cables.....	25
3.7.1 Precautions	25
3.7.2 Bundling Procedure	25
3.8 Verifying Installation.....	25
4 Commissioning.....	26
4.1 Power-on.....	26
4.2 Logging In to the Management Interface.....	26
5 Troubleshooting.....	27
5.1 General Troubleshooting Flowchart	27
5.2 Common Faults.....	27
6 Appendix.....	29
6.1 Connectors and Media.....	29
6.1.1 10Or100Or1000BASE-T Port	29

6.1.2 Optical Cable Connection	30
6.2 SFP Transceivers	30
6.3 Lightning Protection	33
6.3.1 Installing the AC Power Arrester (Power Strip with Surge Protection)	33
6.3.2 Installing the Ethernet Port Arrester	34
6.4 Recommended Cabling	35
6.4.1 Requirement for the Minimum Bend Radius of Cables	35
6.4.2 Precautions for Cable Bundling	35

1 Overview

1.1 About the RG-ES207GS-AC-OD

The RG-ES207GS-AC-OD Ethernet switch provides five 10/100/1000BASE-T ports, two GE SFP ports, one Reset button, and one power input port in the bottom cover. Ports 1–4 support Power over Ethernet (PoE) Out. Multiple LEDs are provided on the front panel. Designed with an IP65-rated housing, the switch is suitable for outdoor use and effectively protects against harsh weather and environmental conditions.

Figure1-1 RG-ES207GS-AC-OD Appearance

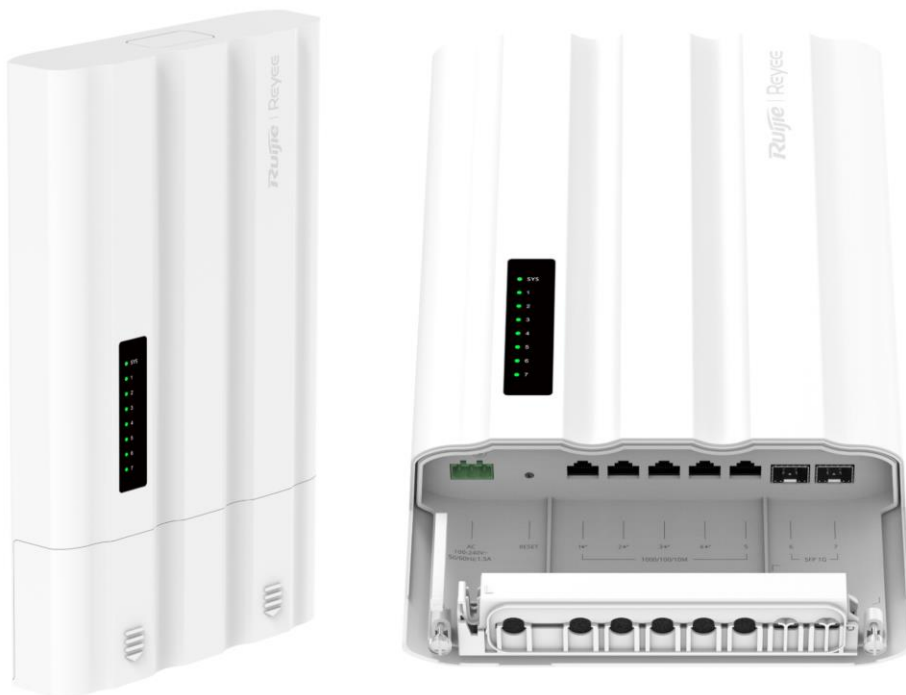

Note

- 1GE SFP port: Supports only 1GE SFP optical transceivers (not compatible with 100 Mbps optical cables).
 - 10/100/1000BASE-T port: Supports auto-negotiation at 10 Mbps, 100 Mbps, and 1000 Mbps.
-

1.2 Equipment Appearance

1.2.1 Front Panel

Figure1-2 Front Panel of the RG-ES207GS-AC-OD

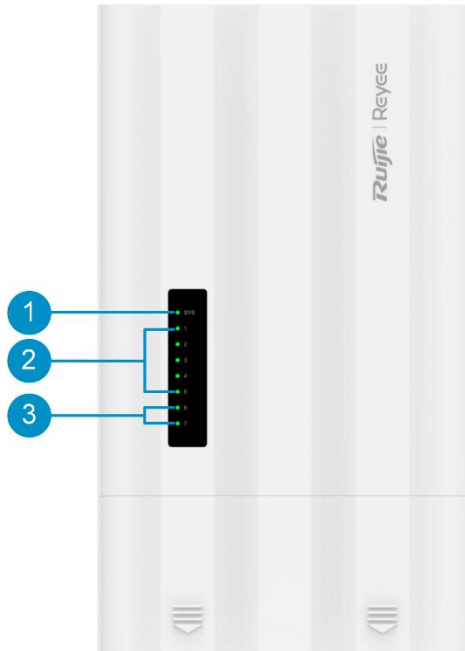
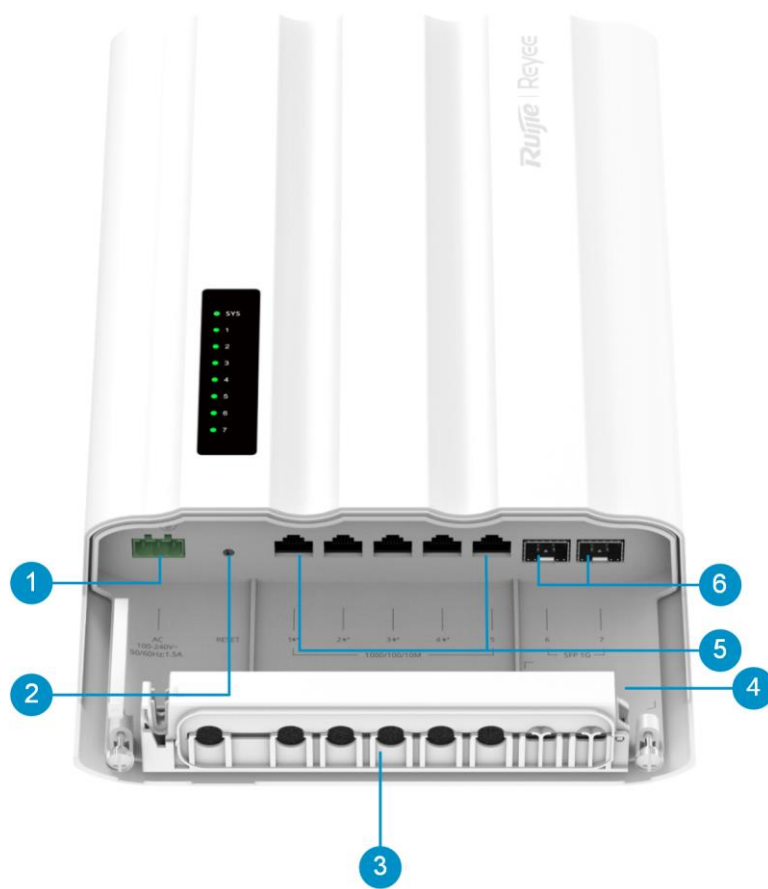

Table1-1 Components on the Front Panel

No.	Component	Silkscreen	Description
1	System status LED	SYS	<ul style="list-style-type: none"> ● Off: The switch is not powered on. ● Slow blinking green (0.5 Hz): The switch is operating normally but is not connected to Ruijie Cloud. ● Fast blinking green (10 Hz): The switch is upgrading or restarting, and is temporarily unavailable. ● Solid green: The switch is operating normally and connected to Ruijie Cloud. ● Slow blinking yellow (0.5 Hz): The PoE power is insufficient. ● Slow blinking red (0.5 Hz): A loop occurs on the switch with loop guard enabled.
2	RJ45 port LED	1–5	<ul style="list-style-type: none"> ● Off: The port is not connected. ● Solid green: The port is operating at 1000 Mbps, 100 Mbps, or 10 Mbps, but is not receiving or sending data. ● Blinking green: The port is operating at 1000 Mbps, 100 Mbps, or 10 Mbps, and is receiving or sending data.
3	SFP port LED	6, 7	<ul style="list-style-type: none"> ● Off: The port is not connected. ● Solid green: The port is operating at 1000 Mbps, but is not receiving or sending data. ● Blinking green: The port is operating at 1000 Mbps, and is receiving or sending data.

1.2.2 Bottom Cover Removal

Figure1-3 RG-ES207GS-AC-OD Bottom Cover Removal



Note

⚡+ indicates the PoE+ ports, which are compliant with IEEE 802.3at, and backward compatible with IEEE 802.3af.

Table1-2 Bottom Cover Removal

No.	Component	Silkscreen	Description
1	Power input port	AC	Three-core AC power input: left (N) — neutral, middle (L) — live, right — ground.
2	Reset button	RESET	<ul style="list-style-type: none"> ● Press and hold the button for less than 2 seconds. The switch is reset. ● Press and hold the button for 2–5 seconds. No action is performed. ● Press and hold the button for more than 5 seconds, and release the button until the system status LED starts blinking to restore factory settings and restart the switch.
3	Cable outlet	-	It prevents water and dust from entering the equipment.

No.	Component	Silkscreen	Description
4	3-in-1 device label	-	<p>This label contains the device SN, MAC address, and QR code.</p> <hr/> <p>⚠ Note:</p> <p>Before installation, take a photo of this label. After installation, use Ruijie Reyee App to scan the QR code and bind the equipment during initial setup.</p> <hr/>
5	RJ45 port	1–5	<p>10/100/1000BASE-T ports, with ports 1–4 supporting PoE Out.</p> <p>Note: You can view the PoE status only by logging in to the switch's eWeb.</p>
6	SFP port	6, 7	<p>1GE SFP port, supporting 1GE SFP transceiver (hot-swappable)</p>

1.2.3 Rear Panel

Figure1-4 Rear Panel of the RG-ES207GS-AC-OD

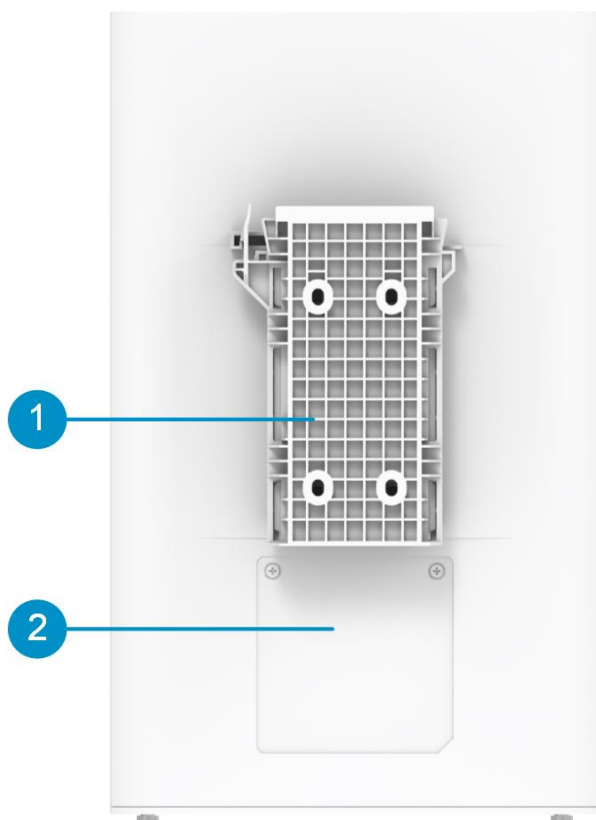

Table1-3 Components on the Rear Panel

No.	Component	Description
1	Mounting plate	Integrated mounting plate on the equipment. It is used to install clamps for pole mount or a mounting bracket for wall mount.
2	Nameplate	Located on the rear panel.

1.3 Cooling

The RG-ES207GS-AC-OD adopts fanless design and uses natural cooling. To ensure that the equipment works properly in the specified environment, maintain sufficient clearance around the equipment for air circulation and ventilation.

1.4 Technical Specifications

! Warning

- The equipment falls into Class A. Therefore, the equipment room should be located away from the residential area. Otherwise, the equipment room should meet construction specifications to avoid noise and radio interference.
- This equipment is not suitable for use in locations where children are likely to be present.
- Operation of this equipment in a residential environment could cause radio interference.
- Double pole/neutral fusing. Risk of electric shock. The circuit breaker is on the neutral wire of the grid power supply. Cut off the grid power supply to disconnect each phase conductor.

**Table1-4 Technical Specifications**

Parameter Type	Parameter Name	RG-ES207GS-AC-OD
System Specifications	Forwarding rate	10.41 Mpps
	Switching capacity	14 Gbps(bit/s)
	Flash memory	8 MB
Port Specifications	Total number of optical ports	2
	Total number of RJ45 ports	5

Parameter Type	Parameter Name	RG-ES207GS-AC-OD
	Number of 10/100/1000BASE-T ports	5
	Number of 1GE SFP ports	2
	Reset button	1
	LEDs	1 x system status LED 5 x Ethernet port LEDs 2 x SFP port LEDs
	DIP switch	NA
Power Supply and Consumption	Power supply	Fixed power supply
	Power input	220 V AC power supply: <ul style="list-style-type: none"> ● Rated input voltage: 100 V AC to 240 V AC, 50 Hz to 60 Hz ● Maximum input voltage: 90 V AC to 264 V AC, 47 Hz to 63 Hz ● Maximum input current: 1.5 A
	Maximum power consumption	4.8 W (with no PoE load) 70 W (with full PoE load)
	Number of PoE Out ports	4
	Number of PoE/PoE+ Out ports	4
	PoE Out standard	PoE/PoE+ (IEEE 802.3af/at)
	PoE power pins	1–2 (+), 3–6 (-)
	PoE budget per port	30 W
	PoE budget	60 W
Dimensions and Weight	Product dimensions (W x D x H)	328mm x 200mm x 62.8mm (12.91 in. x 7.87 in. x 2.47 in.)
	Weight	1.38 kg (3.04 lbs) (without packaging materials)
	Shipping weight	2.17 kg (4.78 lbs)
	Casing	Plastic
Interface	EEE	Yes
Environment and Reliability	Mounting options	Wall/Pole

Parameter Type	Parameter Name	RG-ES207GS-AC-OD
	Hot swapping of cables	Hot swapping supported by the service port and power connector
	Fan	Fanless design
	Cooling	Natural cooling
	MTBF	200,000 hours
	ESD protection	Air discharge: 8 kV Contact discharge: 6 kV
	Surge protection	Service port: ± 8 kV for common mode Power connector: ± 6 kV for common mode and ± 6 kV for differential mode
	Operating temperature	-30°C to $+65^{\circ}\text{C}$ (-22°F to 149°F)
	Storage temperature	-40°C to $+70^{\circ}\text{C}$ (-40°F to $+158^{\circ}\text{F}$)
	Operating humidity	10% RH to 90% RH (non-condensing)
	Storage humidity	5% RH to 95% RH (non-condensing)
	Altitude	-500 m to $+5,000$ m ($-1,640.42$ ft. to $+16,404.20$ ft.)
Certification and Regulatory Compliance	EMC	EN 55032 EN 61000-3-2 EN 61000-3-3 EN 55035 EN 300 386
	Safety compliance	EN 62368-1 IEC 62368-1
	Certification	CE, CB

2 Preparing for Installation

2.1 Package Contents

Table2-1 Package Contents

No.	Item	Quantity
1	RG-ES207GS-AC-OD switch	1
2	User Manual	1
3	Warranty Card	1
4	Terminal block	1
5	Expansion anchor	4
6	Hose clamp	2
7	Mounting bracket	1
8	ST4.2 x 19 mm screw	4

Note

The package contents are subject to the purchase contract, and actual delivery may vary. Please check the items carefully against the package contents or purchase contract. If you have any questions, please contact the distributor.

2.2 Safety Guidelines

Note

- To avoid personal injury or equipment damage, review the safety guidelines in this chapter before you begin the installation.
 - The following safety guidelines may not include all the potentially hazardous situations.
-

2.2.1 General Precautions

- Never operate the equipment in a wet environment, and avoid any liquids inside it. Keep the chassis clean and dust-free.
- Keep the equipment away from heat sources.
- Do not expose the equipment to high temperatures, dust, or harmful gases. Do not install the equipment in flammable or explosive environments. Keep the equipment away from sources of electromagnetic interference (EMI), such as large radar stations, radio stations, and substations. Do not subject the equipment to unstable voltage, vibration, or excessive noise.

- The installation site should be dry. Do not install the equipment in a place near the sea. Keep the equipment at least 500 m (1,640.42 ft.) away from the ocean and do not face it towards the sea breeze.
- The installation site should be free from water flooding, seepage, dripping, or condensation. The installation site should be selected according to network planning, communications equipment features, and considerations such as climate, hydrology, geology, earthquake, electrical power, and transportation.
- During installation and maintenance, do not wear loose clothing or ornament that may get caught in the chassis.
- Keep tools and accessories away from walk areas.

2.2.2 Chassis-Lifting Guidelines

- Avoid moving the equipment frequently.
- Turn off all power supplies and disconnect all cables before lifting or moving the equipment.

2.2.3 Electricity Safety

Warning

- Any deviation from standard or improper electrical operations can result in accidents such as fires or electric shocks, potentially causing severe or even fatal harm to both individuals and equipment.
 - Direct or indirect touch through a wet object on high-voltage and mains supply can bring a fatal danger.
 - Cut off the power supply before equipment maintenance.
-

- Always observe the local regulations and standards. Only qualified personnel should be allowed to operate the equipment.
- Carefully check the work area for potential hazards, including ungrounded power system, absent safety grounds, and damp floors.
- Locate the emergency power-off switch in the room before installation. In the case of an accident, cut off the power supply immediately.
- Never assume that power is connected to or disconnected from a circuit. Always check.
- Select the right leakage protector (also called "leakage current switch" or "leakage current breaker") for the power supply system. This equipment automatically disconnects the power supply in the event of leakage and the risk of electric shock. A leakage protector should meet the following requirements:
 - The rated leakage action current of each leakage protector must be at least twice the total maximum leakage current of all connected power supplies.

Example:

If a system has 16 identical power supplies, each with a maximum leakage current of 3.5 mA:

Total leakage current = $16 \times 3.5 \text{ mA} = 56 \text{ mA}$

For a 30 mA leakage protector:

Maximum number of power supplies per protector = $30 \text{ mA} / 2 / 3.5 \text{ mA} \approx 4$

Therefore, only four power supplies can be connected to one 30 mA leakage protector.

To support 16 power supplies, at least four 30 mA leakage protectors are required.

Always ensure:

Rated leakage operating current/2 > Total maximum leakage current of connected power supplies

- The rated leakage non-action current of a leakage protector should be 50% of the leakage action current. If the non-action current value is too small, the high sensitivity level can cause the circuit to break, leading to power cutoff and service interruption, even if the leakage current value is normal.

For example, if a leakage protector has a rated leakage action current of 30 mA, the rated leakage non-action current should be 15 mA. The leakage protector will not activate unless the leakage current exceeds 15 mA.

⚠ Caution

- To ensure personal safety, each leakage protector in the system must have a rated leakage action current equal to or below 30 mA, which is the recognized safety threshold for human body current. If the total leakage current of the system exceeds twice the 30 mA limit, the system must be equipped with two or more leakage protectors to maintain safety.
 - The leakage current values vary with equipment. For the leakage current value of each equipment model, see "Technical Specifications."
-

2.2.4 Preventing ESD Damage

- Ensure that the chassis is connected to earth ground.
- Maintain appropriate humidity conditions.
- Before installing any pluggable modules, wear an anti-ESD wrist strap and make sure that it is properly grounded.
- Avoid contact between the printed circuit boards and clothing. The anti-ESD wrist strap only protects the printed circuit boards from ESD voltages on the body. ESD voltages on clothing can still cause damage.

2.2.5 Laser Safety

The equipment supports various types of optical transceivers, which are Class 1 laser products.

Precautions:

- When an optical transceiver is working, ensure that its port is connected to an optical cable or covered by a dust cap to keep out dust and prevent it from burning your eyes.
- Do not stare into an optical port.

Figure2-1 Laser Product ID

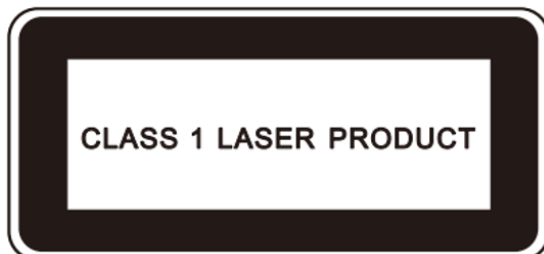

⚠ Caution

Do not approach or stare into an optical port under any circumstances. This may cause permanent damage to your eyes.

2.3 Site Requirements

To ensure the normal operation and prolonged service life of the equipment, the installation site must meet the following requirements.

2.3.1 Floor Loading

Evaluate the weight of the equipment and its accessories, and ensure that the installation site (such as a wall or a pole) can bear the weight.

2.3.2 Airflow

The equipment adopts natural cooling. Reserve a sufficient clearance around the equipment to ensure proper ventilation.

2.3.3 Temperature and Humidity

To ensure the normal operation and a prolonged service life of the equipment, maintain an appropriate temperature and humidity in the installation environment. Prolonged exposure to inappropriate temperature and humidity conditions can cause damage to the equipment.

- In an environment with high relative humidity, insulating materials are prone to poor insulation or even electricity leakage. Sometimes, high humidity may cause changes in the mechanical properties and cause rusting of metal parts.
- In an environment with low relative humidity, insulating gaskets may shrink, resulting in screw loosening.
- A high temperature can accelerate the aging process of insulation materials, greatly reducing the availability of the equipment and severely affecting its service life.

2.3.4 Waterproof

- The Ethernet cables and power cord are routed through the waterproof components before connecting to the equipment (see the following installation steps for details) to ensure waterproofing.
- The screw holes on the equipment are sealed using waterproof plugs or caps to ensure waterproof performance.

2.3.5 Grounding

A proper grounding system is crucial for ensuring stable and reliable operation, as well as preventing lightning strikes and interference. Carefully check the grounding conditions at the installation site according to the grounding requirements, and complete grounding properly based on the site situation.

2.3.6 Preventing Electromagnetic Interference

- Take interference prevention measures for the power supply system.
- Keep the equipment away from the grounding system or lightning protection grounding system of the power facility.

- Keep the equipment far away from high-frequency current equipment such as high-power radio transmitting stations and radar launchers.
- Take electromagnetic shielding measures when necessary.

2.3.7 Surge Protection

Although the equipment can guard against lightning strikes, strong lightning strikes may still damage the equipment. Take the following surge protection measures:

- Ensure that the neutral point of the AC power socket is in good contact with the ground.
- Install a power arrester in front of the power input end to enhance surge protection for the power supply.

2.4 Tools

Table2-2 Tools

Common Tools	Phillips screwdriver, flat-blade screwdriver, cables, diagonal pliers, cable ties, and grounding wires
Dedicated Tools	Anti-ESD gloves, wire stripper, crimping pliers, RJ45 crimping pliers, and wire cutter
Meter	Multimeter

 **Note**

The equipment is delivered without a toolkit. Prepare the preceding tools by yourself.

3 Installing the Switch

⚠ Caution

Before installing the equipment, ensure that guidelines and requirements in Chapter 2 have been met.

3.1 Installation Procedure

Figure3-1 Installation Flowchart

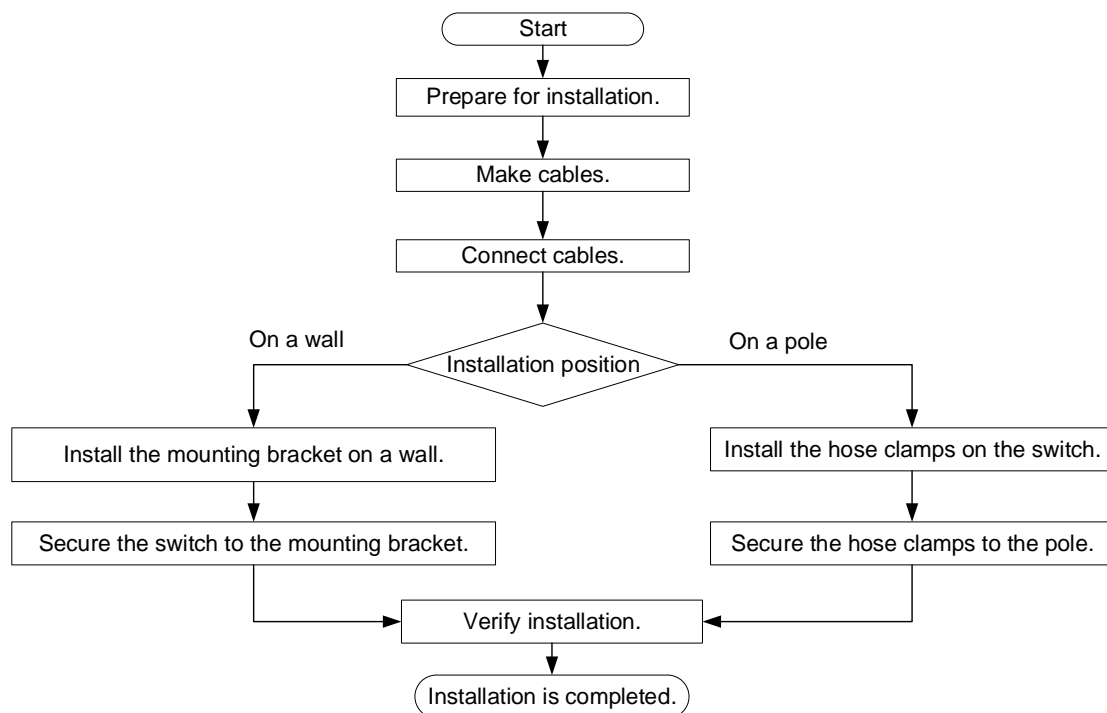

3.2 Before You Begin

Carefully plan and arrange the equipment installation position and cabling before installation. Confirm the following requirements before installation:

- The installation site provides sufficient space for heat dissipation.
- The installation site meets the temperature and humidity requirements.
- The power supply is available at the installation site, and its current meets the requirements.
- The power supply meets the requirements.
- The Ethernet cables have been deployed at the installation site.
- The installation site meets the site requirements of the equipment.

3.3 Installation Precautions

Outdoor switches can be installed on a pole or wall. The recommended diameter range of the pole is from 50 mm (1.97 in.) to 70 mm (2.75 in.). If the pole falls out of this range, you need to prepare other types of hose clamps with a thickness of no less than 2.5 mm (0.1 in.). The equipment must be installed by professionals, and the installation positions are determined by site surveys.

Before installation, ensure that the installation position meets the requirements in [3.2 Before You Begin](#) and pay attention to the following points:

- Do not power on the equipment during installation.
- Place the equipment in a well-ventilated environment.
- Do not subject the equipment to high temperatures.
- Keep the equipment away from high-voltage power cables.
- Do not expose the equipment to a thunderstorm or strong electric field.
- Cut off the power supply before cleaning the equipment.
- Do not open the enclosure when the equipment is working.
- Secure the equipment properly.
- Before installation, take a photo of the label inside the bottom cover. After installation, use Ruijie Reyee App to scan the QR code and bind the equipment during initial setup.

3.4 Making Cables

The power cord must be connected to the terminal block for the RG-ES207GS-AC-OD onsite.

⚠ Caution

The diameter of the power cord must be within the range of 6.1 mm to 6.9 mm (0.24 in. to 0.27 in.). Using thicker or thinner cables does not guarantee dustproof and waterproof performance.

- (1) Use a wire stripper to strip about 1 cm (0.39 in.) of the insulation layer off the power cord.

Figure3-2 Power Cord Stripping

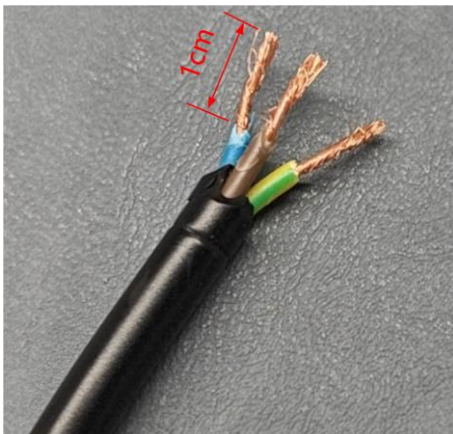

- (2) Use a flat-blade screwdriver to loosen the screws on the terminal block. Insert the wires of the power cord into the corresponding ports of the terminal block and tighten the screws on the terminal block. The neutral, live, and grounding wires of the power cord correspond to the markings (N, L, and ) on the power input port at the bottom of the switch, as shown in the following figure.

Figure3-3 Mapping Between Power Wires and Power Input Port



3.5 Connecting Cables to the Equipment

- (1) Loosen two captive screws at the bottom of the device.

Figure3-4 Connecting Cables to the Equipment (1)

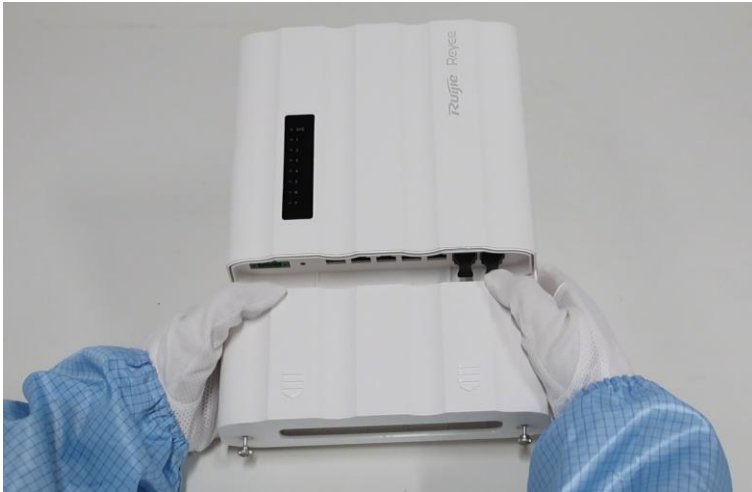

- (2) Press the upper end and sides of the bottom cover and slide it out.

Figure3-5 Connecting Cables to the Equipment (2)

- (3) Press the clip to open the upper cover.

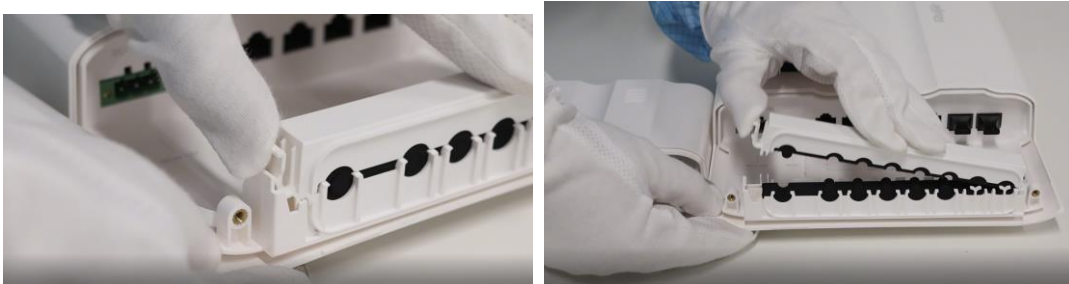
Figure3-6 Connecting Cables to the Equipment (3)

- (4) Lead the power cord, Ethernet cables, and optical cables through the cable holes at the bottom cover.

⚠ Caution

The diameter of a connected Ethernet cable must be within the range of 6.1 mm to 6.9 mm (0.24 in. to 0.27 in.). Using thicker or thinner cables does not guarantee dustproof and waterproof performance. The diameter of a fiber jumper used with the optical transceiver must be within the range of 2.8 mm to 3.2 mm (0.11 in. to 0.13 in.). Using thicker or thinner cables does not guarantee dustproof or waterproof performance.

Figure3-7 Connecting Cables to the Equipment (4)



- (5) Connect the power cord, Ethernet cables, and optical cables.
 - a. Connect the cables to the corresponding ports.

Figure3-8 Connecting Cables to the Equipment (5)

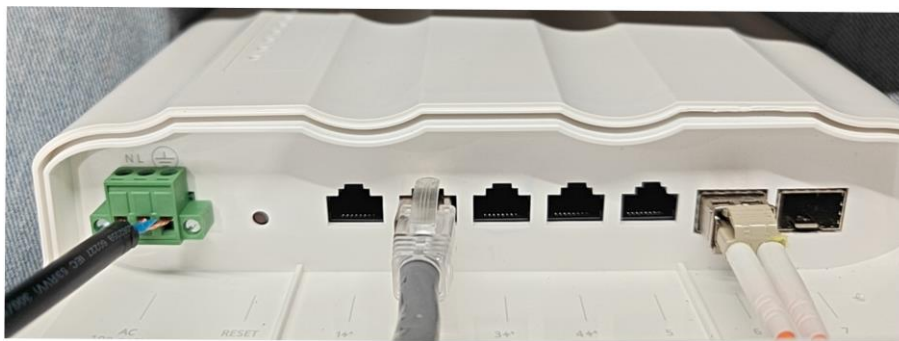

- b. Remove the peelable silicone fillers from the cable positions based on the cable positions and quantity.

Figure3-9 Connecting Cables to the Equipment (6)

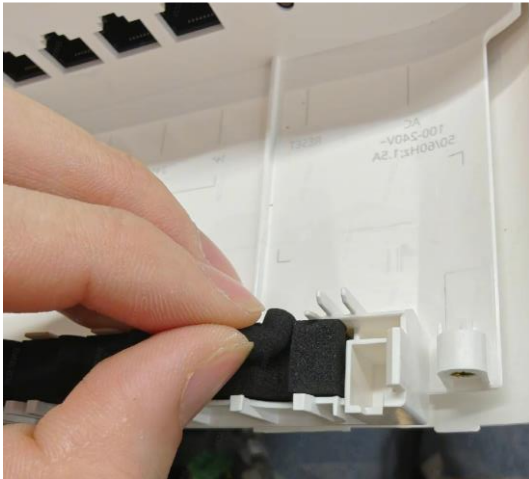

- c. Secure the cables in the grooves.

Figure3-10 Connecting Cables to the Equipment (7)

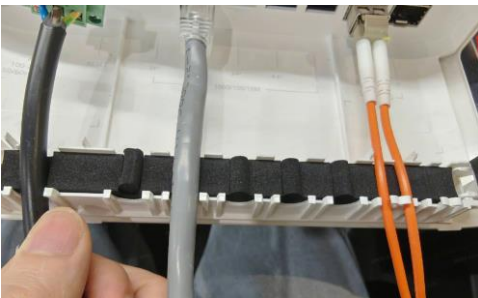

- (6) Close the cover.

Figure3-11 Connecting Cables to the Equipment (8)



- (7) Arrange the cables to ensure correct positioning and proper sealing.

Figure3-12 Connecting Cables to the Equipment (8)

(8) Install the bottom cover and tighten the captive screws.

Figure3-13 Connecting Cables to the Equipment (9)

3.6 Installing the Equipment

3.6.1 Pole Mount

- (1) Take two hose clamps out of the accessories, and loosen the fastening screws on the clamps until the end of the clamps is disengaged.
- (2) Thread the end of the clamps through the bracket holes on the rear of the equipment.

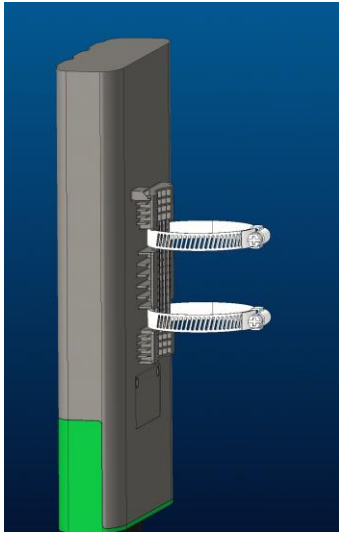
Figure3-14 Installing Clamps on the Rear of the Equipment

- (3) Install clamps at appropriate positions on the pole, and tighten the screws on the clamps to secure the equipment.

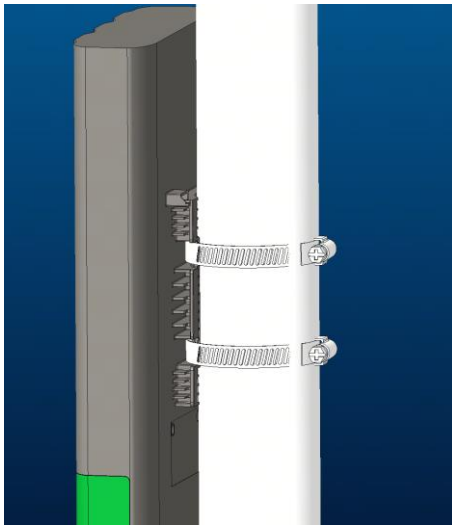
Figure3-15 Securing the Equipment to the Pole

3.6.2 Wall Mount

To mount the switch on a wall, use the delivered mounting bracket, ST4.2 x 19 mm screws, and expansion anchors. The steps are as follows:

- (1) Drill four screw holes (spacing: 30 mm [1.18 in.] horizontally and 78 mm [3.07 in.] vertically) on the wall at appropriate positions according to the hole spacing on the mounting bracket.

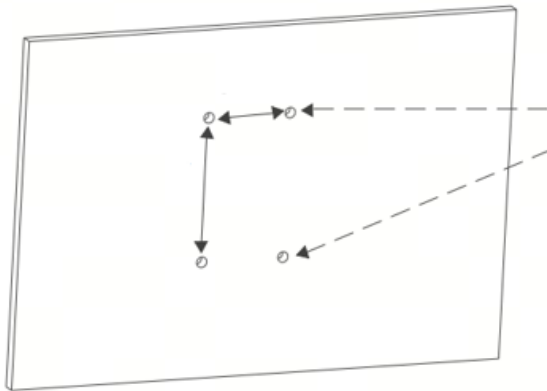
Figure3-16 Drilling Holes on the Wall

- (2) Insert the four expansion anchors into the holes.
- (3) Secure the mounting bracket to the wall with four ST4.2 x 19 mm screws.

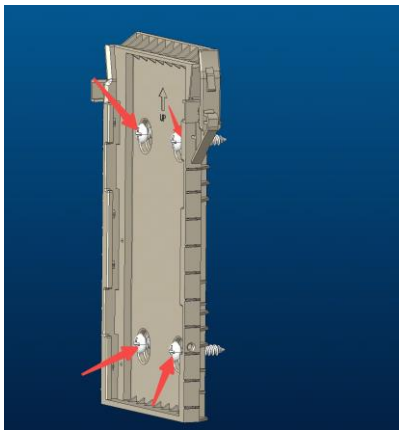
Figure3-17 Fastening the Mounting Bracket

- (4) Align the rear mounting plate of the equipment with the mounting bracket, and push the equipment downward.

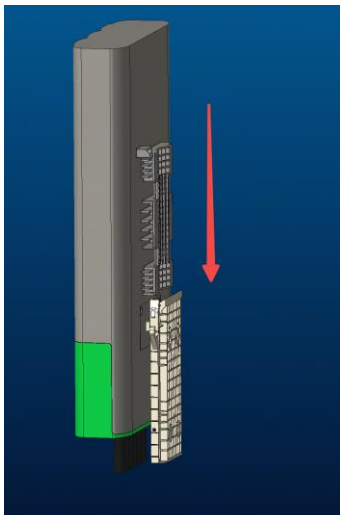
Figure3-18 Securing the Equipment

3.7 Bundling Cables

3.7.1 Precautions

- Bundle the power cord and other cables in an esthetically pleasing way.
- Make sure that the optical cables at the connectors have natural bends or bends of large radius.
- Do not bind optical cables and twisted pairs too tightly, as this may press the cables and affect their service life and transmission performance.

3.7.2 Bundling Procedure

- (1) Bind the drooping part of the optical cables and twisted pairs, and lead them to both sides of the chassis for convenience.
- (2) Bind the power cord closely along the bottom of the chassis, in a straight line wherever possible.

3.8 Verifying Installation

 **Caution**

Please turn off the power to avoid personal injury and damage to components caused by incorrect connection.

- Verify that the cables including power cords are properly connected.
- Verify that there is adequate clearance around the equipment.

4 Commissioning

4.1 Power-on

- (1) Checklist Before Power-on
 - The switch is properly grounded.
 - The power cord is properly connected.
 - The power supply voltage meets the requirement of the switch.
- (2) Checklist After Power-on (Recommended)
 - The switch LEDs are in the normal state.
 - Service ports can forward data properly.

4.2 Logging In to the Management Interface

- (1) Connect a PC to an Ethernet port on the switch through an Ethernet cable.
- (2) Set the IP address of the PC to 10.44.77.XXX (Range: 1–254, excluding 200).

Figure4-1 Changing the IP Address

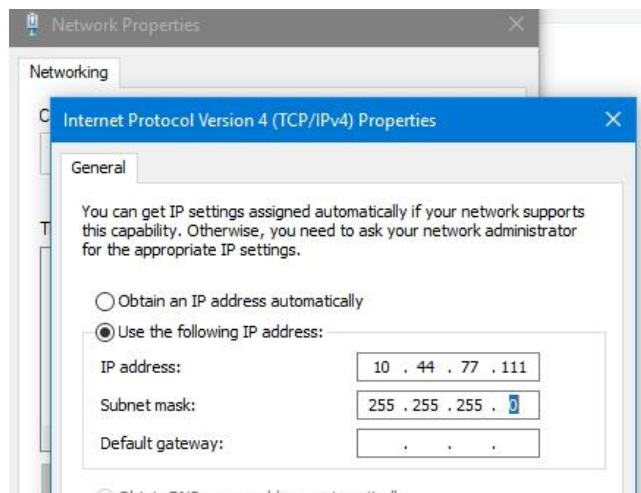

- (3) Open a browser, enter 10.44.77.200 in the address bar, and press Enter. On the login page, set a password and log in.
- (4) Perform equipment commissioning and configuration based on service requirements.

Note

For security purposes, you are advised to change the password regularly.

5 Troubleshooting

5.1 General Troubleshooting Flowchart

Note

You can determine whether each checking item in the process is normal based on the information provided in the previous chapters "Overview" and "Installing the Switch."

Figure5-1 General Troubleshooting Flowchart

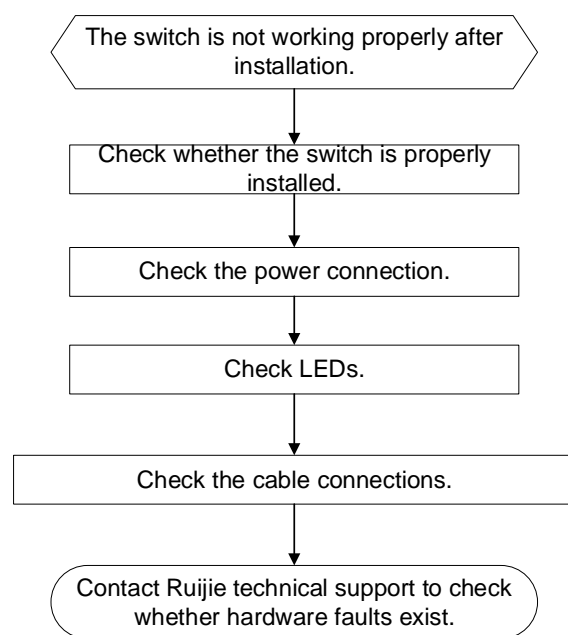

5.2 Common Faults

Table5-1 Common Faults and Troubleshooting

Symptom	Possible Cause	Suggested Action
The system status LED is off after the switch is powered on.	No power is supplied to the switch or the power cord is loosely connected.	Check whether the power supply is normal and whether the power cord is loosely connected to the switch.
An RJ45 port is disconnected or a frame sending/receiving error occurs.	The twisted pair is not connected properly.	Replace the twisted pair.
	The cable length exceeds 100 m (328.08 ft.).	Use an optical cable for data transmission or connect to an intermediate switch for relay.

Symptom	Possible Cause	Suggested Action
	The port is specially configured and does not work in the same mode as that of the interconnected switch.	Check whether the port is configured to work in the same mode as that of the interconnected switch.
An optical port is not reachable.	The transmit and receive ends are connected incorrectly.	Exchange the transmit and receive ends of the optical cable.
	The types of the interconnected optical transceivers do not match.	Replace with one compatible optical transceiver.
	The optical cable type does not meet the requirements.	Replace the optical cable with a qualified one.
	The optical cable length is beyond the allowed length marked on the optical transceiver.	Use an optical cable with the required length.
	The optical cable or connector is contaminated.	Clean the connector with a lint-free cloth or a cleaning pen.
The login password cannot be retrieved.	The password is forgotten, and the equipment is not connected to the network or Ruijie Cloud.	Press and hold the Reset button to restore to factory settings.
	If the equipment is connected to Ruijie Cloud or a network, its login password is updated to the project or global management password.	If the equipment is connected to the cloud, log in using the project management password. If the equipment is connected to a network, log in using the global management password.

6 Appendix

6.1 Connectors and Media

6.1.1 100r100Or1000BASE-T Port

The 10/100/1000BASE-T port supports auto-negotiation for 10 Mbps, 100 Mbps, and 1000 Mbps connections and also supports auto MDI/MDIX Crossover.

Compliant with IEEE 802.3ab, a 1000BASE-T port connects to a 100-ohm Category 5 (CAT5) or Category 5 Enhanced (CAT5e) Unshielded Twisted Pair (UTP), or recommended Shielded Twisted Pair (STP) cable with a maximum distance of 100 m (328.08 ft.).

The 1000BASE-T port requires that all four pairs of wires be connected for data transmission. [Figure6-1](#) shows twisted pair connections for the 1000BASE-T port.

Figure6-1 Twisted Pair Connections for a 1000BASE-T Port

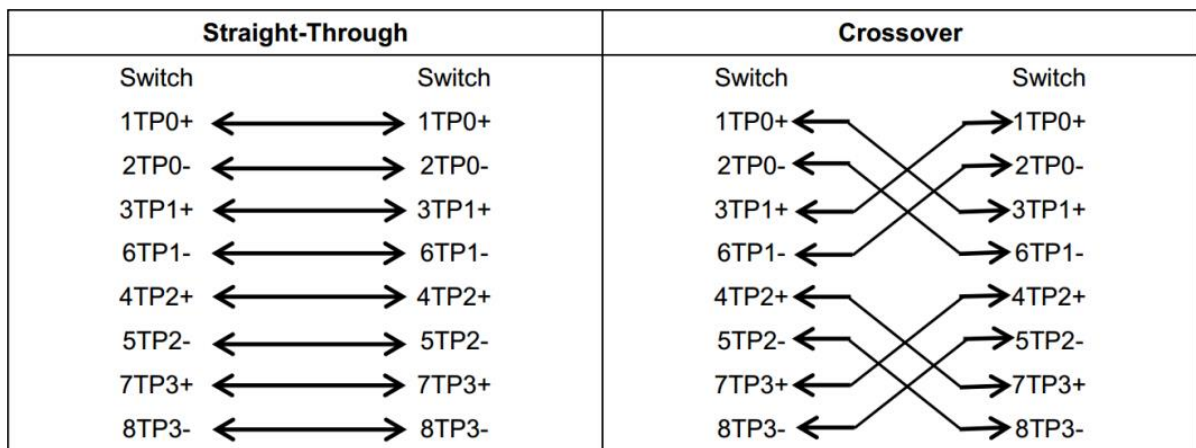

In addition to cables with the above-mentioned specifications, the 10/100BASE-T port can also be connected using 100-ohm CAT3, CAT4, and CAT5 cables at 10 Mbps or using 100-ohm CAT5 cables with a maximum distance of 100 m (328.08 ft.). The following table shows pin assignments for a 10/100BASE-T port.

Table6-1 10/100BASE-T Pin Assignment

Pin	Socket	Plug
1	Input Receive Data+	Output Transmit Data+
2	Input Receive Data-	Output Transmit Data-
3	Output Transmit Data+	Input Receive Data+
6	Output Transmit Data-	Input Receive Data-
4, 5, 7, and 8	Not Used	Not Used

The following table shows wiring of straight-through and crossover cables for a 10/100BASE-T port.

Figure6-2 Twisted Pair Connections for a 10/100BASE-T Port

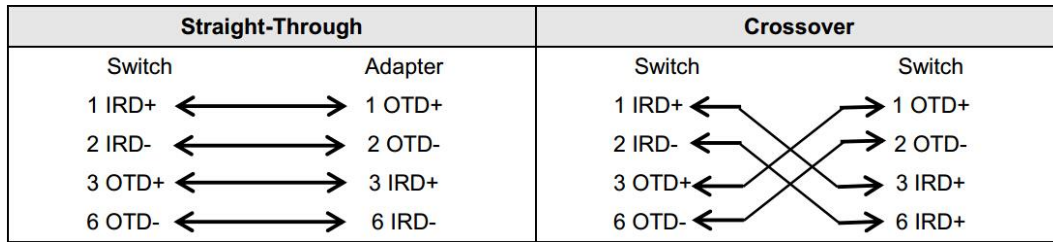

6.1.2 Optical Cable Connection

Select a single-mode fiber (SMF) or multimode fiber (MMF) for connections based on the type of the optical transceiver inserted into an optical port. [Figure6-3](#) shows the connections.

Figure6-3 Connecting the Optical Cables

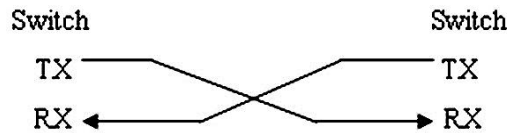

6.2 SFP Transceivers

Ruijie provides SFP transceivers (mini-GBIC) based on the port types. You can select one that suits your specific needs.

The RG-ES207GS-AC-OD is an outdoor switch and its operating temperature ranges from -30°C to +65°C (-22°F to +149°F). When the outdoor temperature is lower than 0°C (32°F) or higher than 40°C (104°F), you are advised to use an industrial-grade optical transceiver on the equipment. When the outdoor temperature ranges from 0°C (32°F) to 40°C (104°F), the following recommended optical transceivers can be used.

In addition to the following 1GE SFP transceivers, the 1GE copper transceiver Mini-GBIC-GT is also supported. This document provides models and technical specifications of some 1GE SFP transceivers for reference. For details about the technical specifications, see *Ruijie Transceiver Installation and Reference Guide*.

Table6-2 1GE Mini-GBIC (SFP) Models and Technical Specifications

Model	Wavelength (nm)	Fiber Type	DDM Supported (Yes/No)	Transmit Power (dBm)		Receive Power (dBm)	
				Min	Max	Min	Max
MINI-GBIC-SX-MM850	850	MMF	Yes	-9	-3	-20	-3
MINI-GBIC-LX-SM1310	1310	SMF	Yes	-9	-3	-26	0

Model	Wavelength (nm)	Fiber Type	DDM Supported (Yes/No)	Transmit Power (dBm)		Receive Power (dBm)	
				Min	Max	Min	Max
GE-SFP-LH40-SM1310-BIDI	1310TX/1550RX	SMF	Yes	-3	3	-25	0
GE-SFP-LH40-SM1550-BIDI	1550TX/1310RX	SMF	Yes	-3	3	-25	0
GE-SFP-LX20-SM1310-BIDI	1310TX/1550RX	SMF	Yes	-8	-3	-23	-3
GE-SFP-LX20-SM1550-BIDI	1550TX/1310RX	SMF	Yes	-8	-3	-23	-3
MINI-GBIC-LH40-SM1310	1310	SMF	Yes	-5	0	-25	-3
MINI-GBIC-ZX80-SM1550	1550	SMF	Yes	-3	3	-26	-3
GE-SFP-LX03-SM1310-BIDI-I	1310TX/1550RX	SMF	Yes	-9	-3	-22	-3
GE-SFP-LX03-SM1550-BIDI-I	1550TX/1310RX	SMF	Yes	-9	-3	-22	-3
SFP-MM850	850	MMF	Yes	-9.5	-3	-17	-3
SFP-SM1310	1310	SMF	Yes	-9	-3	-20	-3

Table6-3 1GE SFP Copper Transceivers

Standard	1000BASE-T SFP Module	DDM Supported (Yes/No)
1000BASE-T	Mini-GBIC-GT	No

Table6-4 Cabling Specifications of SFP Transceivers

SFP Transceiver Model	Port Type	Fiber Type	Core Size (μm)	Max Cabling Distance
SFP-SM1310	LC	SMF	9/125	10 km (6.21 miles)
MINI-GBIC-LX-SM1310	LC	SMF	9/125	10 km (6.21 miles)
GE-SFP-LH40-SM1310-BIDI	LC	SMF	9/125	40 km (24.85 miles)
GE-SFP-LH40-SM1550-BIDI	LC	SMF	9/125	40 km (24.85 miles)

SFP Transceiver Model	Port Type	Fiber Type	Core Size (µm)	Max Cabling Distance
GE-SFP-LX20-SM1310-BIDI	LC	SMF	9/125	20 km (12.43 miles)
GE-SFP-LX20-SM1550-BIDI	LC	SMF	9/125	20 km (12.43 miles)
MINI-GBIC-LH40-SM1310	LC	SMF	9/125	40 km (24.85 miles)
MINI-GBIC-ZX80-SM1550	LC	SMF	9/125	80 km (49.71 miles)
GE-SFP-LX03-SM1310-BIDI-I	LC	SMF	9/125	3 km (1.86 miles)
GE-SFP-LX03-SM1550-BIDI-I	LC	SMF	9/125	3 km (1.86 miles)
MINI-GBIC-SX-MM850	LC	MMF	62.5/125	275 m (902.23 ft.)
			50/125	550 m (1,804.46 ft.)
SFP-MM850	LC	MMF	62.5/125	275 m (902.23 ft.)
			50/125	550 m (1,804.46 ft.)
Mini-GBIC-GT	RJ45	CAT5 or better UTP or STP cable		100 m (328.08 ft.)

⚠ Caution

- For optical transceivers with a cabling distance of no less than 40 km (24.85 miles), install an optical attenuator to avoid overload on an optical receiver when using short-distance SMFs.
- An optical transceiver is a laser transmitter. Do not look into the light source to prevent it from burning your eyes.
- To keep the optical transceiver clean, make sure that the unused ports remain capped.

Table6-5 BIDI Optical Transceiver Pairing

Rate/Distance	Pairing Model
1000 Mbps/3 km (1.86 miles)	GE-SFP-LX03-SM1310-BIDI-I GE-SFP-LX03-SM1550-BIDI-I
1000 Mbps/20 km (12.43 miles)	GE-SFP-LX20-SM1310-BIDI GE-SFP-LX20-SM1550-BIDI
1000 Mbps/40 km (24.85 miles)	GE-SFP-LH40-SM1310-BIDI GE-SFP-LH40-SM1550-BIDI

⚠ Caution

BIDI optical transceivers must be used in pairs. For example, if GE-SFP-LX20-SM1310-BIDI is used at one end, GE-SFP-LX20-SM1550-BIDI must be used at the other end.

6.3 Lightning Protection

6.3.1 Installing the AC Power Arrester (Power Strip with Surge Protection)

When an alternating current (AC) power cord is introduced from outdoors and directly connected to the AC power port of the switch, the power port must be connected to an external power arrester to safeguard the switch against lightning strikes. The power arrester can be fixed on the rack, workbench, or wall in the equipment room by using cable ties and screws. AC power enters the power arrester before entering the switch.

Figure6-4 Power Arrester

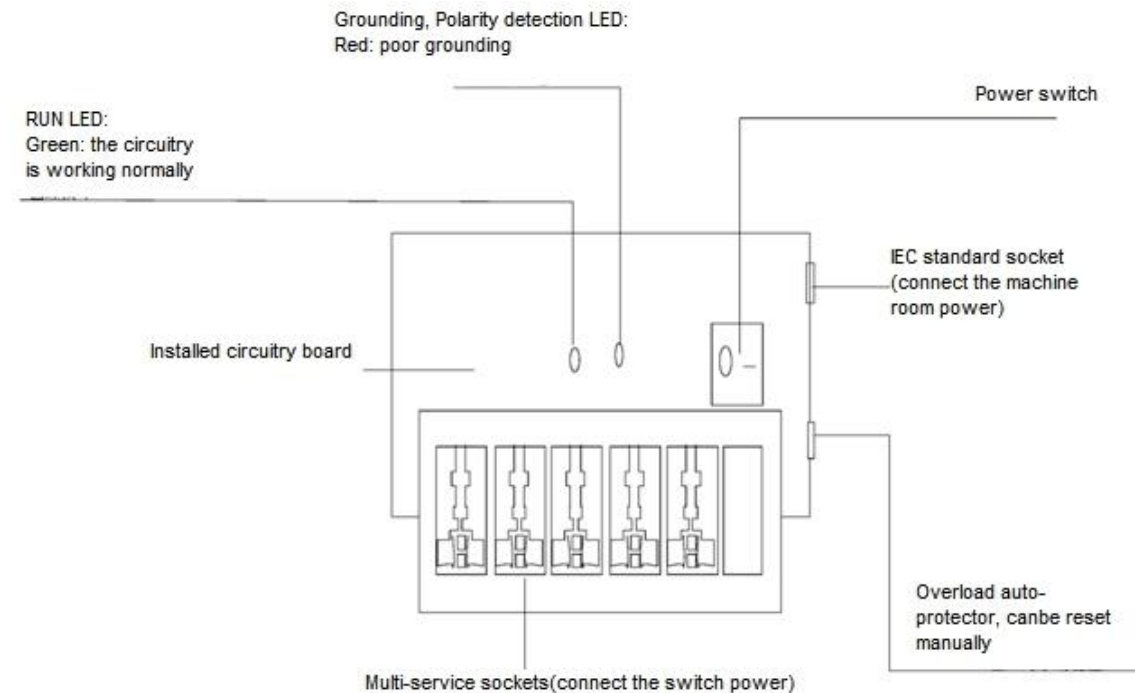

Caution

The power arrester is not delivered with the equipment. Please purchase it based on actual requirements.

Precautions during the installation:

- Make sure that the PE terminal of the power arrester is well grounded.
- After the AC power plug of the switch is connected to the socket of the power arrester, the lightning protection function is implemented only if the running status LED is green and the alarm LED is off.
- If the alarm LED on the power arrester is red, check whether it is caused by a poor grounding connection or by the reversed connection of the neutral and live wires. The detection method is as follows: Use a multimeter to measure the polarity of the power arrester when the alarm LED is red. If the neutral wire is on the left and the live wire is on the right (facing the socket), the PE terminal of the power arrester is not grounded. If not, the polarity of the power arrester should be reversed. In this case, open the power arrester and reverse its polarity. If the alarm LED is still red, the PE terminal of the power arrester is not grounded.

6.3.2 Installing the Ethernet Port Arrester

Please connect an Ethernet port arrester to the switch to prevent the damage by lightning strikes before connecting an outdoor Ethernet cable to the switch.

- Tools: Phillips screwdriver or flat-blade screwdriver, multimeter, and diagonal pliers
- Installation steps
 - a. Tear one side of the protective paper for the double-sided adhesive tape and paste the tape to the enclosure of the Ethernet port arrester. Tear the other side of the protective paper for the double-sided adhesive tape and paste the Ethernet port arrester to the switch enclosure. The paste position for the Ethernet port arrester should be as close to the grounding lug of the switch as possible.
 - b. Based on the distance between the grounding lug of the switch and the Ethernet port arrester, cut the grounding cable of the Ethernet port arrester and firmly tighten the grounding cable to the grounding lug of the switch.
 - c. Use a multimeter to check whether the grounding cable for the arrester is in good contact with the grounding lug and the enclosure of the switch.
 - d. Connect the Ethernet port arrester by using an adapter cable (note that the external Ethernet cable is connected to the IN end, while the adapter cable connected to the switch is connected to the OUT end) and check whether the module LED is normal.
 - e. Use a nylon cable tie to bind the cables.

Figure6-5 Installing an Ethernet Port Arrester

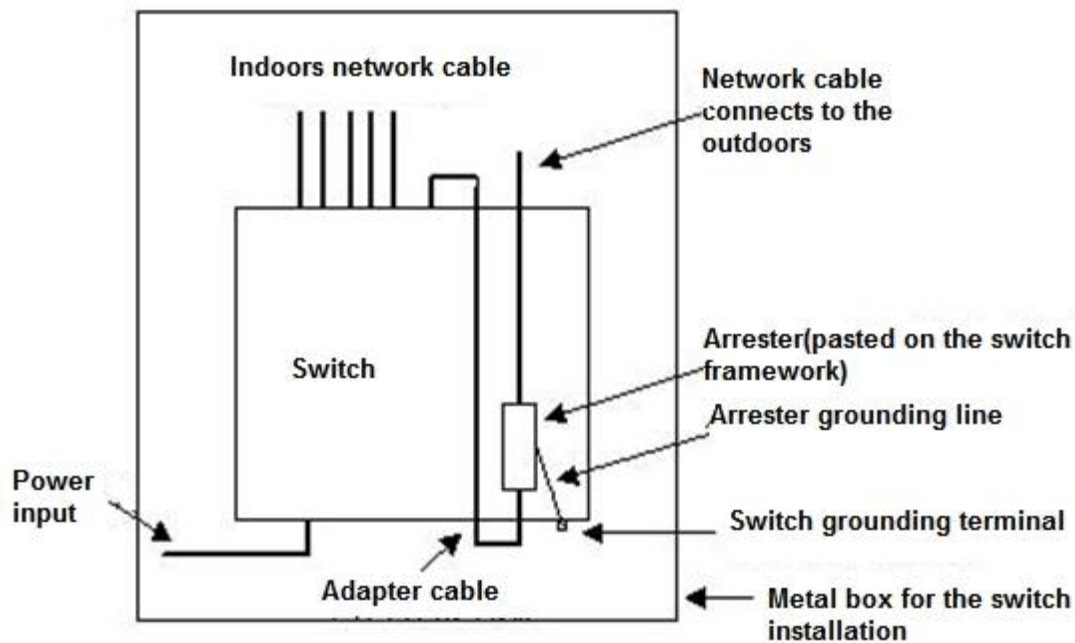

⚠ Caution

- The Ethernet port arrester is only for a 10 Mbps, 100 Mbps, or 1000 Mbps RJ45 port.

- The Ethernet port arrester is not delivered with the equipment. Please purchase it based on actual requirements. The user manual for Ethernet port arresters contains technical parameters and maintenance and installation instructions. Carefully read this manual during installation.
-

Pay attention to the following situations during the actual installation to avoid influencing the performance of an Ethernet port arrester:

- The arrester is incorrectly connected to the cables. Connect the external Ethernet cable to the IN end and connect the Ethernet port of the switch to the OUT end.
- The Ethernet port arrester is incorrectly grounded. The grounding cable of the arrester should be as short as possible to ensure that it is in good contact with the grounding lug of the switch. Use a multimeter to confirm the contact condition after grounding.
- Not all Ethernet ports are installed with Ethernet port arresters. If outdoor Ethernet cables connect the switch ports to the peer equipment, Ethernet port arresters need to be installed on all the ports for the purpose of lightning protection.

6.4 Recommended Cabling

When the switch is installed in a standard 19-inch cabinet, secure the cables around the cable management brackets. Top cabling or bottom cabling is adopted according to the actual situation in the equipment room. All adapted connectors should be placed at the bottom of the rack in an orderly manner instead of outside the rack that is easy to touch. Power cords are routed beside the rack. Top cabling or bottom cabling is adopted according to the actual situation in the equipment room, such as the positions of the DC power distribution box, AC socket, or lightning protection box.

6.4.1 Requirement for the Minimum Bend Radius of Cables

- The bend radius of a fixed power cord, Ethernet cable, and flat cable should be over five times greater than their respective external diameters. The bend radius of these cables that are often bent or plugged should be over seven times greater than their respective external diameters.
- The bend radius of a fixed common coaxial cable should be over seven times greater than its external diameter. The bend radius of these cables that are often bent or plugged should be over 10 times greater than their respective external diameters.
- The minimum bend radius of a high-speed cable, such as an SFP+ cable, should be 5 times the overall diameter of the cable. If the cable is constantly bent, plugged or unplugged, the bend radius should be 10 times the overall diameter.
- The minimum bend radius of optical cables should meet the following requirements.
 - The diameter of the optical cable tray should be no less than 25 times greater than that of the optical cable.
 - When an optical cable is moved, its bend radius should be no less than 20 times greater than its diameter.
 - During cabling of an optical cable, its bend radius should be no less than 10 times greater than its diameter.

6.4.2 Precautions for Cable Bundling

- Before cables are bundled, mark labels and stick the labels to cables wherever appropriate.

- Cables should be neatly and properly bundled in the rack without twisting or bending, as shown in [Figure6-6](#).

Figure6-6 Bundling Cables (1)

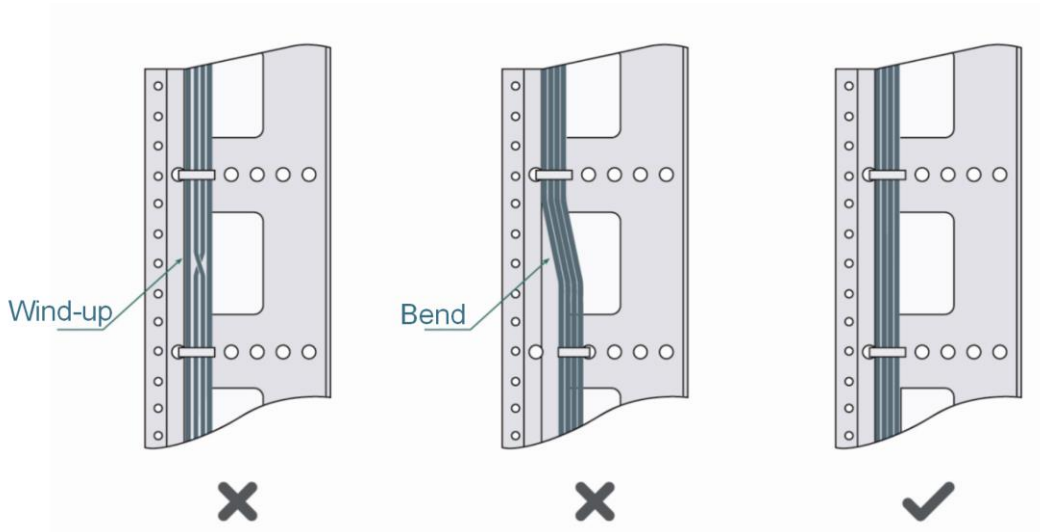

- Cables of different types (such as power cords, signal cables, and grounding wires) should be separated in cabling and bundling. Mixed bundling is not allowed. When they are close to each other, you are advised to adopt crossover cabling. In the case of parallel cabling, maintain a minimum distance of 30 mm (1.18 in.) between power cords and signal cables.
- The cable management brackets and cabling troughs inside and outside the rack should be smooth without sharp corners.
- The metal holes traversed by cables should have a smooth and fully rounded surface or an insulated lining.
- Use cable ties to bundle cables properly. Please do not connect two or more cable ties to bundle cables.
- After bundling up cables with cable ties, cut off the remaining part. The cut should be smooth and trim without sharp corners, as shown in [Figure6-7](#).

Figure6-7 Bundling Cables (2)

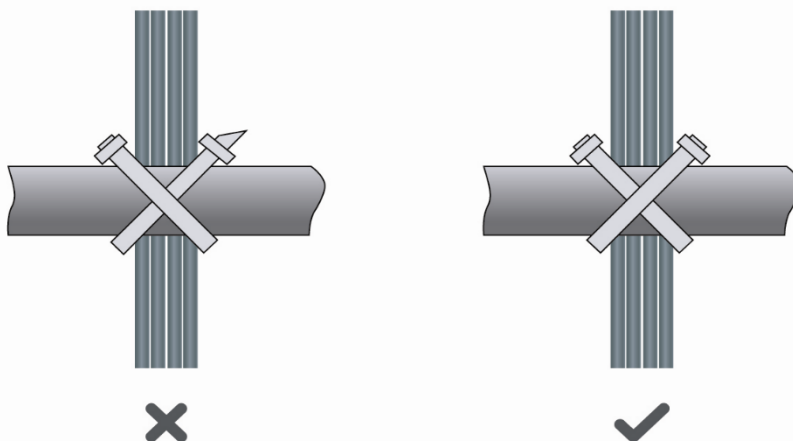

- When cables need to be bent, bundle them first but do not tie cables within the bend. Otherwise, stress may be generated on the cables and cause the wires inside to break, as shown in [Figure6-8](#).

Figure6-8 Bundling Cables (3)

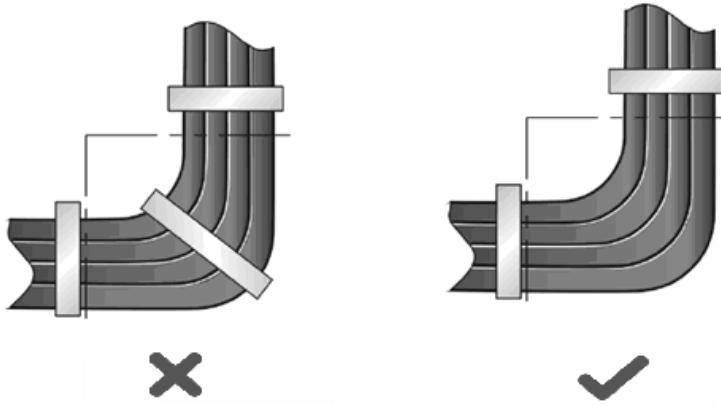

- Cables not to be assembled or the remaining parts of cables should be folded and placed in a proper position of the rack or cable management trough. The proper position refers to a position that does not affect the equipment running or damage the equipment or cables.
- Power cords must not be bundled on the guide rails of moving parts.
- The power cords connecting moving parts such as door grounding wires should be reserved with some excess after being assembled to avoid suffering tension or stress. When a moving part reaches the installation position, the remaining cable part should not touch heat sources, sharp corners, or sharp edges. If heat sources must be touched, high-temperature cables should be used.
- When using screw threads to secure a cable lug, ensure that the bolt or screw is properly tightened and take measures to prevent it from loosening, as shown in [Figure6-9](#).

Figure6-9 Fastening Cables

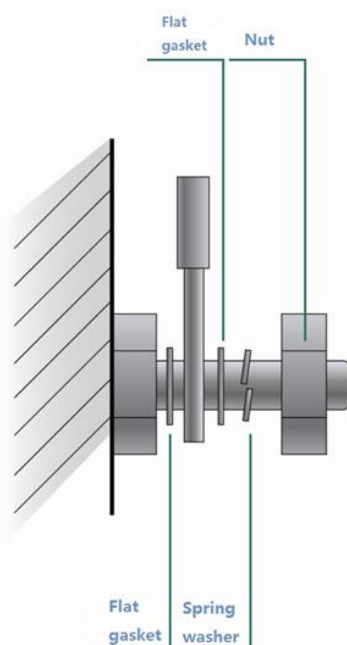

- Hard power cords should be secured near the cable termination area to prevent stress on the cable termination area and cables.
- Do not use tapping screws to secure cable lugs.
- Power cords of the same type and in the same cabling direction should be bundled up into cable bunches, with cables in cable bunches clean and straight.
- Bundle cables by using cable ties according to the following table.

Cable Bunch Diameter	Bundling Spacing
10 mm (0.39 in.)	80–150 mm (3.15–5.91 in.)
10–30 mm (0.39–1.18 in.)	150–200 mm (5.91–7.87 in.)
30 mm (1.18 in.)	200–300 mm (7.87–11.81 in.)

- Do not tie cables or bundles in a knot.
- For wiring terminal blocks (such as circuit breakers) with cord end terminals, the metal part of the cord end terminal should not be exposed outside the terminal block when assembled.

Contents

1 Overview	4
1.1 About the RG-ES207GS-HP.....	4
1.2 Equipment Appearance	4
1.2.1 Front Panel.....	4
1.2.2 Rear Panel	5
1.2.3 LEDs	6
1.3 Cooling.....	7
1.4 Technical Specifications	7
2 Preparing for Installation	11
2.1 Package Contents.....	11
2.2 Safety Guidelines.....	11
2.2.1 General Precautions	11
2.2.2 Chassis-Lifting Guidelines	11
2.2.3 Electricity Safety	12
2.2.4 Preventing ESD Damage.....	13
2.2.5 Laser Safety	13
2.3 Site Requirements	13
2.3.1 Floor Loading	13
2.3.2 Airflow.....	13
2.3.3 Space	14
2.3.4 Temperature and Humidity.....	14
2.3.5 Cleanliness.....	14

2.3.6 Grounding	15
2.3.7 Preventing Electromagnetic Interference	15
2.3.8 Surge Protection	15
2.3.9 Installation Site.....	16
2.4 Tools	16
3 Installing the Switch	17
3.1 Before You Begin.....	17
3.2 Installing the Switch	17
3.2.1 Wall Mount	17
3.2.2 Workbench Mount.....	18
3.3 Grounding the Equipment.....	18
3.4 Connecting Cables.....	19
3.5 Bundling Cables.....	19
3.5.1 Precautions	19
3.5.2 Bundling Procedure	19
3.6 Verifying Installation.....	19
4 Commissioning.....	21
4.1 Power-on.....	21
4.2 Logging In to the Management Interface.....	21
5 Troubleshooting.....	22
5.1 General Troubleshooting Flowchart	22
5.2 Common Faults.....	22
6 Appendix.....	24
6.1 Connectors and Media.....	24

6.1.1 10Or100Or1000BASE-T Port	24
6.1.2 Optical Cable Connection	25
6.2 SFP Transceivers	25
6.3 Lightning Protection	28
6.3.1 Installing the AC Power Arrester (Power Strip with Surge Protection)	28
6.3.2 Installing the Ethernet Port Arrester	29
6.4 Recommended Cabling	30
6.4.1 Requirement for the Minimum Bend Radius of Cables	30
6.4.2 Precautions for Cable Bundling	31
6.5 Site Selection	33

1 Overview

1.1 About the RG-ES207GS-HP

The RG-ES207GS-HP Ethernet switch provides six 10/100/1000BASE-T ports, one 1GE SFP port, one Reset button, and several LEDs on the front panel, along with a 54 V DC power port, a DIP switch, and a grounding stud on the rear panel. Ports 1–4 support Power over Ethernet (PoE) Out.

Figure 1-1 RG-ES207GS-HP Appearance

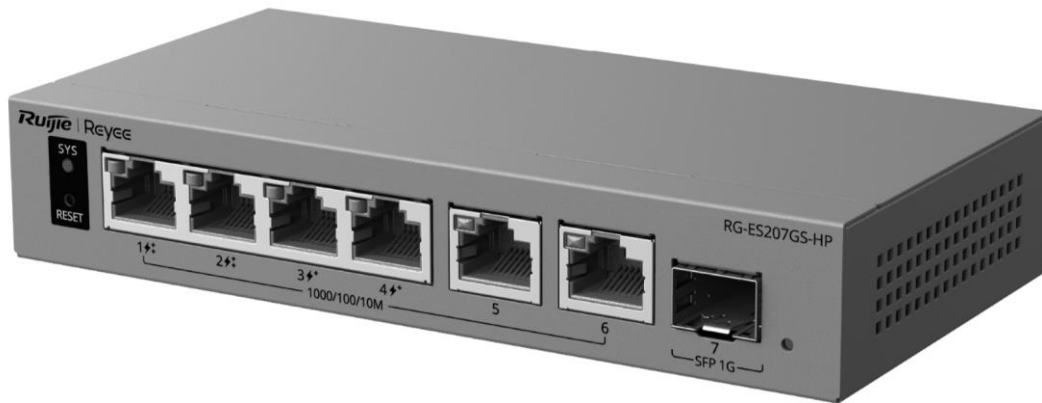

Note

- 1GE SFP port: Supports only 1GE SFP optical transceivers (not compatible with 100 Mbps optical cables).
 - 10/100/1000BASE-T port: Supports auto-negotiation at 10 Mbps, 100 Mbps, and 1000 Mbps.
-

1.2 Equipment Appearance

1.2.1 Front Panel

Figure 1-2 Front Panel of the RG-ES207GS-HP

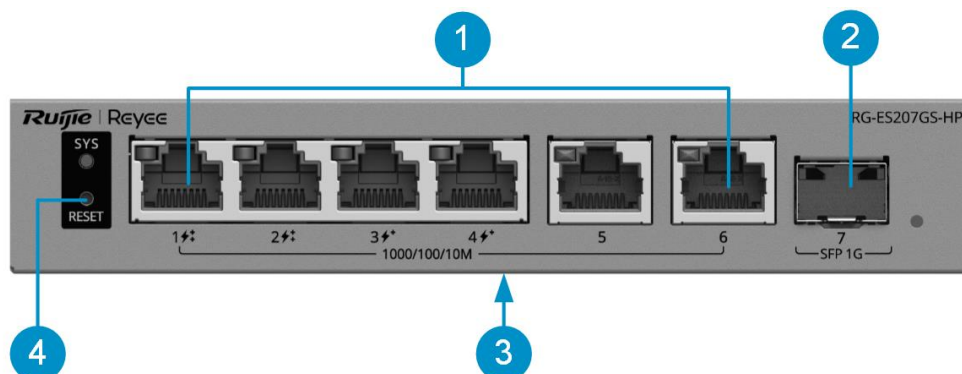

Note



-  indicates the PoE++ ports, which are compliant with IEEE 802.3bt, and backward compatible with IEEE 802.3af and IEEE 802.3at.
-  indicates the PoE+ ports, which are compliant with IEEE 802.3at, and backward compatible with IEEE 802.3af.

Table 1-1 Components on the Front Panel

No.	Component	Silkscreen	Description
1	RJ45 port	1–6	10/100/1000BASE-T ports: (1) Ports 1 and 2 support PoE, PoE+, and PoE++. (2) Ports 3 and 4 support PoE and PoE+. (3) Ports 5 and 6 do not support PoE.
2	SFP port	7	1GE SFP port, supporting 1GE SFP transceiver (hot-swappable)
3	Nameplate	-	It is located at the bottom of the switch.
4	Reset button	RESET	<ul style="list-style-type: none"> ● Press and hold the button for less than 2 seconds. The switch is reset. ● Press and hold the button for 2–5 seconds. No action is performed. ● Press and hold the button for more than 5 seconds, and release the button until the system status LED starts blinking to restore factory settings and restart the switch.

Note

For details about LEDs on the front panel, see "LEDs."

1.2.2 Rear Panel

Figure 1-3 Rear Panel of the RG-ES207GS-HP

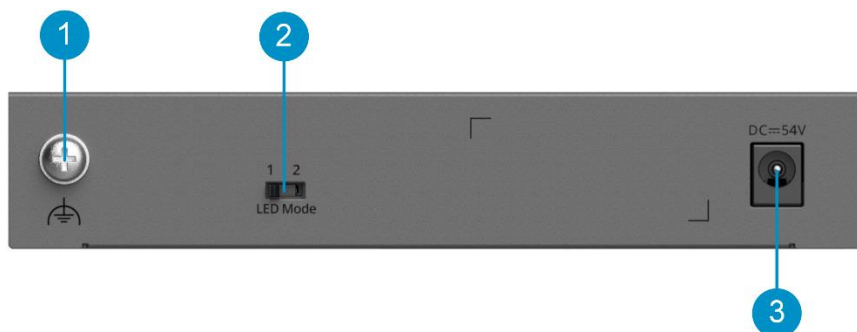

Table 1-2 Components on the Rear Panel

No.	Component	Description
1	Grounding stud	It is connected to a grounding wire.
2	DIP switch	Toggle the DIP switch to change the LED modes of ports 1–4. <ul style="list-style-type: none"> LED mode 1 (switching mode): When the DIP switch is toggled to the left, the port LEDs display the data transmission status. LED mode 2 (PoE mode): When the switch is toggled to the right, the port LEDs display the PoE status.
3	DC power port	It is connected to a 54 V DC power source to supply power to the switch. The matching DC power connector has an outer diameter of 5.5 mm (0.22 in.), an inner diameter of 2.1 mm (0.08 in.), and a depth of 10 mm (0.39 in.).

1.2.3 LEDs

Figure 1-4 RG-ES207GS-HP LEDs

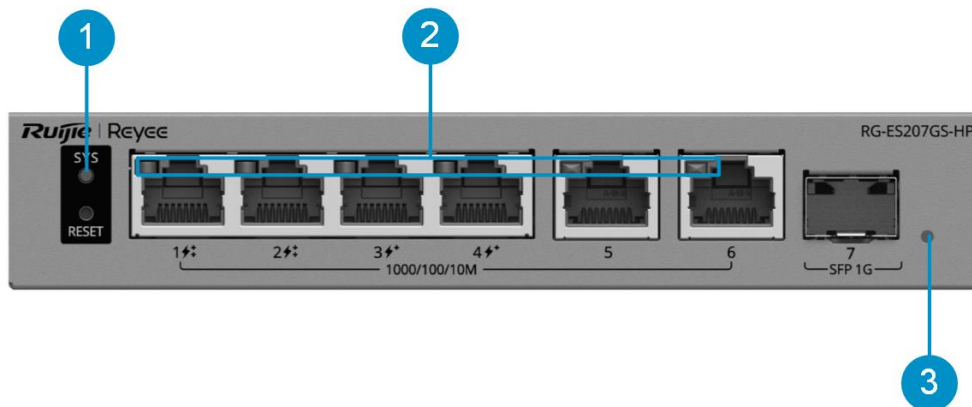

Table 1-3 LEDs

No.	Component	Silkscreen	Description
1	System status LED	SYS	<ul style="list-style-type: none"> Off: The switch is not powered on. Slow blinking green (0.5 Hz): The switch is operating normally but is not connected to Ruijie Cloud. Fast blinking green (10 Hz): The switch is upgrading or restarting, and is temporarily unavailable. Solid green: The switch is operating normally and connected to Ruijie Cloud. Slow blinking yellow (0.5 Hz): The PoE power is insufficient. Slow blinking red (0.5 Hz): A loop occurs on the switch with loop guard enabled.
2	RJ45 port LED	-	LEDs of ports 1–4 support switching mode and PoE mode, which can be switched by toggling the DIP switch on the rear of the switch.

No.	Component	Silkscreen	Description
			<p>LEDs of ports 5 and 6 support only switching mode.</p> <ul style="list-style-type: none"> ● Switching mode: <ul style="list-style-type: none"> ○ Off: The port is not connected. ○ Solid green: The port is operating at 1000 Mbps, 100 Mbps, or 10 Mbps, but is not receiving or sending data. ○ Blinking green: The port is operating at 1000 Mbps, 100 Mbps, or 10 Mbps, and is receiving or sending data. ● PoE mode: <ul style="list-style-type: none"> ○ Off: PoE is disabled on the port. ○ Solid green: PoE is enabled on the port. ○ Blinking green: PoE overload occurs on the port.
3	SFP port LED	-	<ul style="list-style-type: none"> ● Off: The port is not connected. ● Solid green: The port is operating at 1000 Mbps, but is not receiving or sending data. ● Blinking green: The port is operating at 1000 Mbps, and is receiving or sending data.

1.3 Cooling

The RG-ES207GS-HP adopts fanless design and uses natural cooling. To ensure that the equipment works properly in the specified environment, a minimum clearance of 10 cm (3.94 in.) must be maintained around the equipment for air circulation and ventilation.

1.4 Technical Specifications

Warning

- This equipment is not suitable for use in locations where children are likely to be present.
- Operation of this equipment in a residential environment could cause radio interference.

Table 1-4 Technical Specifications

Parameter Type	Parameter Name	RG-ES207GS-HP
System Specifications	Forwarding rate	10.41 Mpps
	Switching capacity	14 Gbps(bit/s)
	Flash memory	8 MB
Port Specifications	Total number of optical ports	1
	Total number of RJ45 ports	6

Parameter Type	Parameter Name	RG-ES207GS-HP
	Number of 10/100/1000BASE-T ports	6
	Number of 1GE SFP ports	1
	Reset button	1
	LEDs	1 x system status LED 6 x Ethernet port LEDs 1 x SFP port LED
	DIP switch	LED mode switch toggled to left (Mode 1): The port LED status indicates the status of traffic transmission. Solid green means that the port is link up, while blinking green means that the port is transmitting and receiving data. LED mode switch toggled to right (Mode 2): The port LED status indicates the PoE status. Solid green means that the port is supplying power, while blinking green means that the port is in power overload state.
Power Supply and Consumption	Power supply	<ul style="list-style-type: none"> ● DC power adapter
	Power input	DC adapter: <ul style="list-style-type: none"> ● Rated input voltage: 100 V AC to 240 V AC, 50 Hz to 60 Hz ● Maximum input voltage: 90 V AC to 264 V AC, 47 Hz to 63 Hz ● Rated input current: 2 A Output : <ul style="list-style-type: none"> ● Rated output voltage: 54 V DC ● Maximum output current: 2.5 A
	Maximum power consumption	5 W (with no PoE load) 125 W (with full PoE load)
	Number of PoE Out ports	4

Parameter Type	Parameter Name	RG-ES207GS-HP
	Number of PoE/PoE+ Out ports	4
	Number of PoE/PoE+/PoE++ Out ports	2
	PoE Out standard	Port 1-2 : PoE/PoE+/PoE++ (IEEE 802.3af/at/bt) Port 3-4 : PoE/PoE+ (IEEE 802.3af/at)
	PoE power pins	Port 1-2 : 1-2 (-), 3-6 (+), 4-5 (+), 7-8 (-) Ports 3-4: 1-2 (+), 3-6 (-)
	PoE budget per port	Port 1-2: 90 W Port 3-4: 30 W
	PoE budget	120 W
Dimensions and Weight	Product dimensions (W x D x H)	155mm x 78mm x 28mm (6.10 in. x 3.07 in. x 1.10 in.)
	Weight	0.29 kg (0.64 lbs) (without packaging materials)
	Shipping weight	1.2 kg (2.65 lbs)
	Casing	Metal
Interface	EEE	Yes
Environment and Reliability	Mounting options	Wall/Desk
	Hot swapping of cables	Hot swapping supported by the service port and power connector
	Fan	Fanless design
	Cooling	Natural cooling
	MTBF	200,000 hours
	ESD protection	Air discharge: 8 kV Contact discharge: 6 kV
	Surge protection	Service port: ± 6 kV for common mode

Parameter Type	Parameter Name	RG-ES207GS-HP
		Power connector: ± 4 kV for common mode and ± 2 kV for differential mode
	Operating temperature	0°C to +40°C (32°F to 104°F)
	Storage temperature	-40°C to +70°C (-40°F to +158°F)
	Operating humidity	10% RH to 90% RH (non-condensing)
	Storage humidity	5% RH to 95% RH (non-condensing)
	Altitude	-500 m to +5,000 m (-1,640.42 ft. to +16,404.20 ft.)
Certification and Regulatory Compliance	EMC	EN 55032 EN 61000-3-2 EN 61000-3-3 EN 55035 EN 300 386
	Safety compliance	EN 62368-1 IEC 62368-1
	Certification	CE,CB

2 Preparing for Installation

2.1 Package Contents

Table 2-1 Package Contents

No.	Item	Quantity
1	RG-ES207GS-HP switch	1
2	User Manual	1
3	Warranty Card	1
4	Power adapter	1
5	Power cord	1

Note

The package contents are subject to the purchase contract, and actual delivery may vary. Please check the items carefully against the package contents or purchase contract. If you have any questions, please contact the distributor.

2.2 Safety Guidelines

Note

- To avoid personal injury or equipment damage, review the safety guidelines in this chapter before you begin the installation.
 - The following safety guidelines may not include all the potentially hazardous situations.
-

2.2.1 General Precautions

- Never operate the equipment in a wet environment, and avoid any liquids inside it. Keep the chassis clean and dust-free.
- Keep the equipment away from heat sources.
- Keep the equipment away from walk areas.
- During installation and maintenance, do not wear loose clothing or ornament that may get caught in the chassis.
- Keep tools and accessories away from walk areas.

2.2.2 Chassis-Lifting Guidelines

- Avoid moving the equipment frequently.
- Turn off all power supplies and disconnect all cables before lifting or moving the equipment.

2.2.3 Electricity Safety

Warning

- Any deviation from standard or improper electrical operations can result in accidents such as fires or electric shocks, potentially causing severe or even fatal harm to both individuals and equipment.
 - Direct or indirect touch through a wet object on high-voltage and mains supply can bring a fatal danger.
-

- Always observe the local regulations and standards. Only qualified personnel should be allowed to operate the equipment.
- Carefully check the work area for potential hazards, including ungrounded power system, absent safety grounds, and damp floors.
- Locate the emergency power-off switch in the room before installation. In the case of an accident, cut off the power supply immediately.
- Never assume that power is connected to or disconnected from a circuit. Always check.
- Select the right leakage protector (also called "leakage current switch" or "leakage current breaker") for the power supply system. This equipment automatically disconnects the power supply in the event of leakage and the risk of electric shock. A leakage protector should meet the following requirements:
 - The rated leakage action current of each leakage protector must be at least twice the total maximum leakage current of all connected power supplies.

Example:

If a system has 16 identical power supplies, each with a maximum leakage current of 3.5 mA:

Total leakage current = $16 \times 3.5 \text{ mA} = 56 \text{ mA}$

For a 30 mA leakage protector:

Maximum number of power supplies per protector = $30 \text{ mA} / 3.5 \text{ mA} \approx 4$

Therefore, only four power supplies can be connected to one 30 mA leakage protector.

To support 16 power supplies, at least four 30 mA leakage protectors are required.

Always ensure:

Rated leakage operating current/2 > Total maximum leakage current of connected power supplies

- The rated leakage non-action current of a leakage protector should be 50% of the leakage action current. If the non-action current value is too small, the high sensitivity level can cause the circuit to break, leading to power cutoff and service interruption, even if the leakage current value is normal.

For example, if a leakage protector has a rated leakage action current of 30 mA, the rated leakage non-action current should be 15 mA. The leakage protector will not activate unless the leakage current exceeds 15 mA.

Caution

- To ensure personal safety, each leakage protector in the system must have a rated leakage action current equal to or below 30 mA, which is the recognized safety threshold for human body current. If the total leakage current of the system exceeds twice the 30 mA limit, the system must be equipped with two or more leakage protectors to maintain safety.
 - The leakage current values vary with equipment. For the leakage current value of each equipment model, see "Technical Specifications."
-

2.2.4 Preventing ESD Damage

- Ensure that the chassis is connected to earth ground.
- Keep the site as dust free as possible.
- Maintain appropriate humidity conditions.
- Before installing any pluggable modules, wear an anti-ESD wrist strap and make sure that it is properly grounded.
- Avoid contact between the printed circuit boards and clothing. The anti-ESD wrist strap only protects the printed circuit boards from ESD voltages on the body. ESD voltages on clothing can still cause damage.

2.2.5 Laser Safety

The equipment supports various types of optical transceivers, which are Class 1 laser products.

Precautions:

- When an optical transceiver is working, ensure that its port is connected to an optical cable or covered by a dust cap to keep out dust and prevent it from burning your eyes.
- Do not stare into an optical port.

Figure 2-1 Laser Product ID



⚠ Caution

Do not approach or stare into an optical port under any circumstances. This may cause permanent damage to your eyes.

2.3 Site Requirements

The equipment must be installed indoors for normal operation and prolonged service life.

The installation site must meet the following requirements.

2.3.1 Floor Loading

Assess the combined weight of the equipment and its accessories, such as chassis and power modules, and verify that the floor under the rack can bear the weight.

2.3.2 Airflow

The equipment adopts natural cooling. Reserve a sufficient clearance around the equipment to ensure proper ventilation.

2.3.3 Space

Do not install the equipment against a wall. Instead, maintain a minimum clearance of 10 cm (3.94 in.) around the equipment for heat dissipation and equipment maintenance.

2.3.4 Temperature and Humidity

To ensure the normal operation and a prolonged service life of the equipment, maintain an appropriate temperature and humidity in the installation environment.

Prolonged exposure to inappropriate temperature and humidity conditions can cause damage to the equipment.

- In an environment with high relative humidity, insulating materials are prone to poor insulation or even electricity leakage.
- In an environment with low relative humidity, insulating gaskets may shrink, resulting in screw loosening.
- In a dry environment, static electricity is more likely to occur, posing a risk to the internal circuits of equipment.
- A high temperature can accelerate the aging process of insulation materials, greatly reducing the availability of the equipment and severely affecting its service life.

2.3.5 Cleanliness

Dust poses a significant hazard to the equipment. Dust on the enclosure causes electrostatic adhesion, leading to poor contact of the metallic joints. Electrostatic adhesion is more likely to occur in an indoor environment with relatively low humidity, not only affecting the service life of the equipment, but also causing communication faults. The following table lists the requirements for dust concentration and particle size in the equipment room.

Table 2-2 Requirements for Dust

Particle Diameter	Unit	Concentration
≥ 0.5 μm	Particles/m ³	≤ 3.5 × 10 ⁶
≥ 5 μm	Particles/m ³	≤ 3.5 × 10 ⁶

Apart from dust, there are also requirements on the salt, acid, and sulfide in the air of the equipment room. These harmful substances will accelerate metal corrosion and component aging. Therefore, the equipment room should be properly protected against harmful gases, such as sulfur dioxide, hydrogen sulfide, nitrogen dioxide, and chlorine gas. The following table lists the limits on harmful gases.

Table 2-3 Requirements for Gases

Gas	Average (mg/m ³)	Maximum (mg/m ³)
Sulfur dioxide (SO ₂)	0.3	1.0
Hydrogen sulfide (H ₂ S)	0.1	0.5
Nitrogen dioxide (NO ₂)	0.5	1.0
Chlorine gas (Cl ₂)	0.1	0.3

Note

Average refers to the average value of harmful gases measured in a week. **Maximum** refers to the upper limit of harmful gases measured in a week for up to 30 minutes every day.

2.3.6 Grounding

A proper grounding system is crucial for ensuring stable and reliable operation, as well as preventing lightning strikes and interference. Carefully check the grounding conditions at the installation site according to the grounding requirements, and complete grounding properly based on the site situation.

- Safety Grounding

Ensure that the power distribution system is securely grounded if the equipment uses the AC power supply. Otherwise, electric shocks may occur when the insulation resistance between the power module and the chassis decreases.

Caution

- The building should provide a protective ground connection to ensure that the equipment is connected to a protective ground.
 - Verify that the AC socket is reliably connected to the protective grounding system of the building. If not, a protective grounding wire should be used to connect the protective grounding lug of the AC socket to the protective grounding system of the building.
-

- Lightning Grounding

The lightning protection system is an independent system composed of a lightning rod, a downlead conductor, and a connector connected to the grounding system. The grounding system is typically used for power reference grounding and safety grounding. Lightning grounding is required only for facilities, and is not required for the equipment.

- EMC Grounding

Electromagnetic compatibility (EMC) grounding includes shielded grounding, filter grounding, noise and interference suppression, and level reference.

2.3.7 Preventing Electromagnetic Interference

- Take interference prevention measures for the power supply system.
- Keep the equipment away from the grounding system or lightning protection grounding system of the power facility.
- Keep the equipment far away from high-frequency current equipment such as high-power radio transmitting stations and radar launchers.
- Take electromagnetic shielding measures when necessary.

2.3.8 Surge Protection

Although the equipment can guard against lightning strikes, strong lightning strikes may still damage the equipment. Take the following surge protection measures:

- Ensure that the grounding wire is in good contact with the ground.

- Ensure that the neutral point of the AC power socket is in good contact with the ground.
- Install a power arrester in front of the power input end to enhance surge protection for the power supply.

2.3.9 Installation Site

Regardless of whether the equipment is installed on a wall or a workbench, ensure that the following conditions are met:

- Maintain a proper clearance around the equipment for heat dissipation.
- Alternatively, place the equipment on a clean workbench. The installation of air conditioners is recommended in hot areas.

2.4 Tools

Table 2-4 Tools

Common Tools	Phillips screwdriver, cables, cage nuts, diagonal pliers, cable ties, and grounding wires
Dedicated Tools	Anti-ESD gloves, wire stripper, crimping pliers, RJ45 crimping pliers, and wire cutter
Meter	Multimeter

 **Note**

The equipment is delivered without a toolkit. Prepare the preceding tools by yourself.

3 Installing the Switch

⚠ Caution

Before installing the equipment, ensure that guidelines and requirements in Chapter 2 have been met.

3.1 Before You Begin

- The installation site provides sufficient space for heat dissipation.
- The installation site meets the temperature and humidity requirements.
- The power supply is available at the installation site, and its current meets the requirements.
- The Ethernet cables have been deployed at the installation site.
- Locate the emergency power-off switch in the room before installation. In the case of an accident, cut off the power supply immediately.

3.2 Installing the Switch

3.2.1 Wall Mount

i Note

- You need to prepare two M3 screws and two plastic expansion anchors for wall mounting.
 - For wall mounting, install the equipment only on concrete or other non-flammable surfaces.
-

The steps for wall mounting a switch are as follows:

- (1) Drill two holes at suitable positions on the wall with a spacing of 112.6 mm (4.43 in.). The hole diameter and depth depend on the specifications of the purchased plastic expansion anchors.
- (2) Insert two plastic expansion anchors into the drilled holes, and then screw two M3 screws into the plastic expansion anchors.

i Note

- Ensure that the distance between the inner side of the screw heads and the outer edge of the plastic expansion anchors is at least 2.5 mm (0.1 in.) to securely mount the equipment onto the screws.
 - The equipment appearance shown in the installation diagram is for reference only.
-

- (3) Mount the equipment on the two M3 screws, as shown in the following figure.

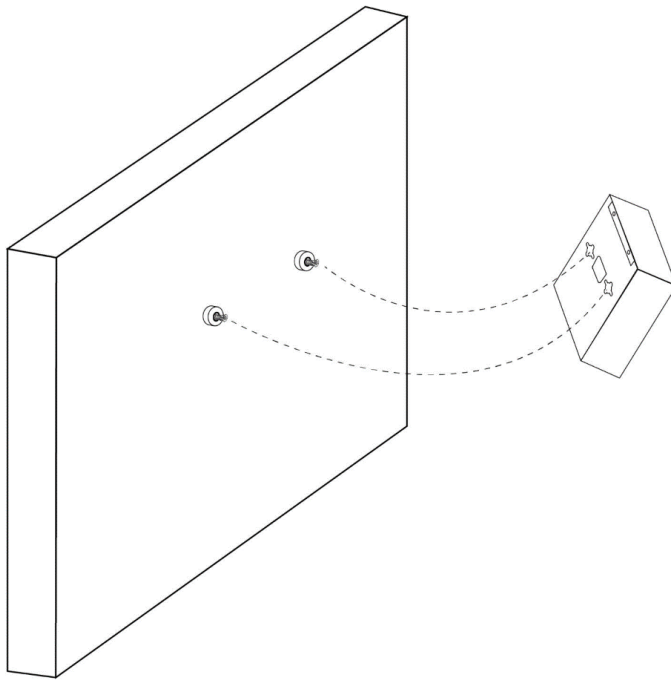
Figure 3-1 Mounting the Switch on a Wall

3.2.2 Workbench Mount

If wall mounting is not feasible, place the switch on a clean workbench and choose a location where it is unlikely to be touched, to ensure the safety and stability of the switch.

3.3 Grounding the Equipment

Note

- If the equipment is installed on a workbench, connect the grounding wire to the nearest grounding bar or grounding point based on the onsite situation.
 - The grounding wire is not delivered with the equipment and needs to be purchased by the customer.
-

The equipment has a grounding stud on the rear panel. You are advised to connect the system grounding wire to it before using the equipment.

- (1) Purchase a grounding wire and connect one end to the grounding stud at the rear of the equipment.
 - (2) Connect the other end of the grounding wire to the nearest grounding bar or grounding point.
-

Caution

- To avoid personal injury and equipment damage, connect the switch to earth ground properly. The grounding resistance between the chassis and the ground should be less than 1 ohm.
 - The O&M personnel should verify whether the AC socket is reliably connected to the protective ground of the building. If not, the O&M personnel should use a protective grounding wire to connect the protective grounding lug of the AC socket to the protective ground of the building.
 - The power socket should be installed near the equipment and easily accessible.
 - During the equipment installation, connect the grounding wire first and disconnect it last.
-

- The sectional area of a grounding wire should be determined according to the possible maximum current. Grounding wires with good conductors should be used.
 - Do not use bare wires.
-

3.4 Connecting Cables

Caution

- All cables must be routed indoors. Take surge protection measures if they need to be routed outdoors.
 - When connecting an optical cable, connect the transmit (TX) port on the local equipment to the receive (RX) port on the peer equipment, and vice versa.
-

After the switch is installed, connect the switch to other equipment according to the following steps:

- (1) Connect the power cord delivered with the switch to the power strip.
- (2) Connect the RJ45 connector of a twisted pair to an Ethernet port on the switch, and the other end to downlink equipment.
- (3) Insert an optical transceiver into the optical port first according to the panel identification. Then connect a single-mode fiber (SMF) or multimode fiber (MMF) to the corresponding optical transceiver, during which the transmitting and receiving ends of the optical cable should be distinguished.

3.5 Bundling Cables

3.5.1 Precautions

- Bundle the power cord and other cables in an esthetically pleasing way.
- Make sure that the optical cables at the connectors have natural bends or bends of large radius.
- Do not bind optical cables and twisted pairs too tightly, as this may press the cables and affect their service life and transmission performance.

3.5.2 Bundling Procedure

- (1) Bind the drooping part of the optical cables and twisted pairs, and lead them to both sides of the chassis for convenience.
- (2) Bind the power cord closely along the bottom of the chassis, in a straight line wherever possible.

3.6 Verifying Installation

Caution

Please turn off the power to avoid personal injury and damage to components caused by incorrect connection.

- Verify that the grounding wire is connected.
- Verify that the cables including power cords are properly connected.
- Verify that cables connected to ports are routed indoors.
- Verify that the surge protection socket and Ethernet port arrester are installed, if outdoor cabling exists.

- Verify that there is a minimum clearance of 10 cm (3.94 in.) around the switch.

4 Commissioning

4.1 Power-on

- (1) Checklist Before Power-on
 - The switch is properly grounded.
 - The power cord is properly connected.
 - The power supply voltage meets the requirement of the switch.
- (2) Checklist After Power-on (Recommended)
 - The switch LEDs are in the normal state.
 - Service ports can forward data properly.

4.2 Logging In to the Management Interface

- (1) Connect a PC to an Ethernet port on the switch through an Ethernet cable.
- (2) Set the IP address of the PC to 10.44.77.XXX (Range: 1–254, excluding 200).

Figure 4-1 Changing the IP Address

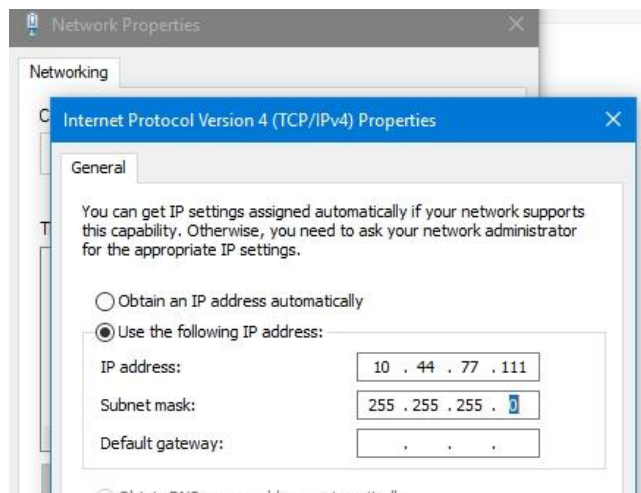

- (3) Open a browser, enter 10.44.77.200 in the address bar, and press Enter. On the login page, set a password and log in.
- (4) Perform equipment commissioning and configuration based on service requirements.

Note

For security purposes, you are advised to change the password regularly.

5 Troubleshooting

5.1 General Troubleshooting Flowchart

Note

You can determine whether each checking item in the process is normal based on the information provided in the previous chapters "Overview" and "Installing the Switch."

Figure 5-1 General Troubleshooting Flowchart

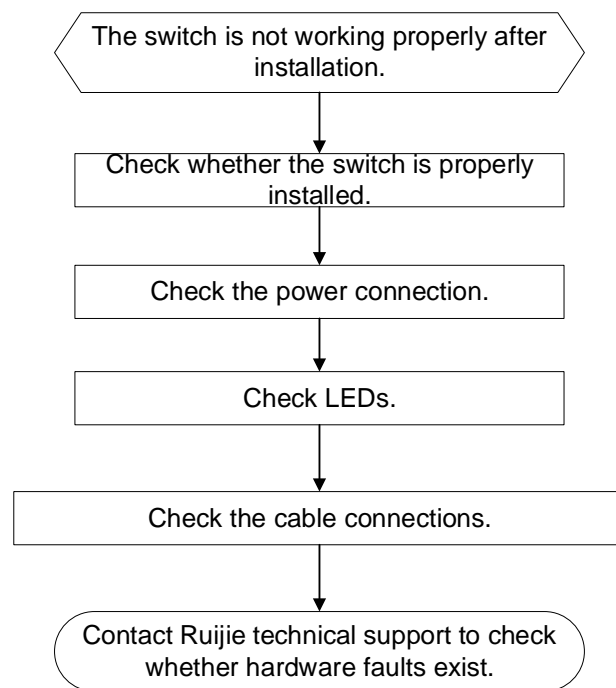

5.2 Common Faults

Table 5-1 Common Faults and Troubleshooting

Symptom	Possible Cause	Suggested Action
The system status LED is off after the switch is powered on.	No power is supplied to the switch or the power cord is loosely connected.	Check whether the power socket in the equipment room is normal and whether the power cord is loosely connected to the switch.
An RJ45 port is disconnected or a frame	The twisted pair is not connected properly.	Replace the twisted pair.

Symptom	Possible Cause	Suggested Action
sending/receiving error occurs.	The cable length exceeds 100 m (328.08 ft.).	Use an optical cable for data transmission or connect to an intermediate switch for relay.
	The port is specially configured and does not work in the same mode as that of the interconnected switch.	Check whether the port is configured to work in the same mode as that of the interconnected switch.
An optical port is not reachable.	The transmit and receive ends are connected incorrectly.	Exchange the transmit and receive ends of the optical cable.
	The types of the interconnected optical transceivers do not match.	Replace with one compatible optical transceiver.
	The optical cable type does not meet the requirements.	Replace the optical cable with a qualified one.
	The optical cable length is beyond the allowed length marked on the optical transceiver.	Use an optical cable with the required length.
	The optical cable or connector is contaminated.	Clean the connector with a lint-free cloth or a cleaning pen.
The login password cannot be retrieved.	The password is forgotten, and the equipment is not connected to the network or Ruijie Cloud.	Press and hold the Reset button to restore to factory settings.
	If the equipment is connected to Ruijie Cloud or a network, its login password is updated to the project or global management password.	If the equipment is connected to the cloud, log in using the project management password. If the equipment is connected to a network, log in using the global management password.
The Ethernet ports are transmitting and receiving frames normally, but their LEDs are off.	<p>The status of the Ethernet port LEDs is incorrectly displayed.</p> <p>The DIP switch is set to LED mode 2. As a result, the Ethernet port LEDs display the PoE status, but PoE is disabled on the ports.</p>	Set the DIP switch to LED mode 1 so that the Ethernet port LEDs display the data receiving and sending status.

6 Appendix

6.1 Connectors and Media

6.1.1 100r100Or1000BASE-T Port

The 10/100/1000BASE-T port supports auto-negotiation for 10 Mbps, 100 Mbps, and 1000 Mbps connections and also supports auto MDI/MDIX Crossover.

Compliant with IEEE 802.3ab, a 1000BASE-T port connects to a 100-ohm Category 5 (CAT5) or Category 5 Enhanced (CAT5e) Unshielded Twisted Pair (UTP), or recommended Shielded Twisted Pair (STP) cable with a maximum distance of 100 m (328.08 ft.).

The 1000BASE-T port requires that all four pairs of wires be connected for data transmission. [Figure 6-1](#) shows twisted pair connections for the 1000BASE-T port.

Figure 6-1 Twisted Pair Connections for a 1000BASE-T Port

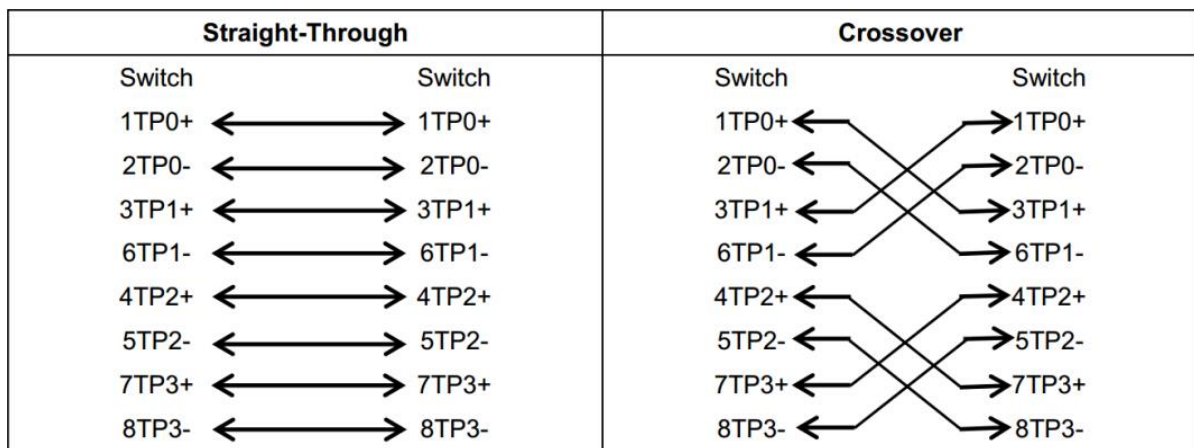

In addition to cables with the above-mentioned specifications, the 10/100BASE-T port can also be connected using 100-ohm CAT3, CAT4, and CAT5 cables at 10 Mbps or using 100-ohm CAT5 cables with a maximum distance of 100 m (328.08 ft.). The following table shows pin assignments for a 10/100BASE-T port.

Table 6-1 10/100BASE-T Pin Assignment

Pin	Socket	Plug
1	Input Receive Data+	Output Transmit Data+
2	Input Receive Data-	Output Transmit Data-
3	Output Transmit Data+	Input Receive Data+
6	Output Transmit Data-	Input Receive Data-
4, 5, 7, and 8	Not Used	Not Used

The following table shows wiring of straight-through and crossover cables for a 10/100BASE-T port.

Figure 6-2 Twisted Pair Connections for a 10/100BASE-T Port

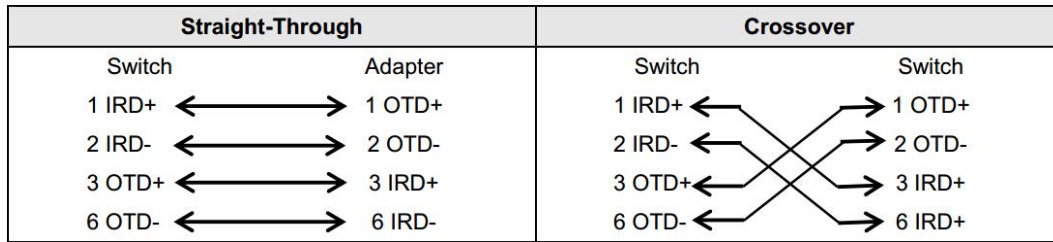

6.1.2 Optical Cable Connection

Select a single-mode fiber (SMF) or multimode fiber (MMF) for connections based on the type of the optical transceiver inserted into an optical port. [Figure 6-3](#) shows the connections.

Figure 6-3 Connecting the Optical Cables

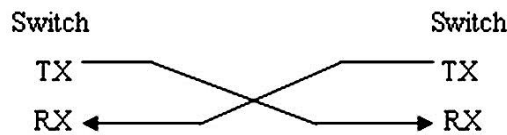

6.2 SFP Transceivers

Ruijie provides SFP transceivers (mini-GBIC) based on the port types. You can select one that suits your specific needs. In addition to the following 1GE SFP transceivers, the 1GE copper transceiver Mini-GBIC-GT is also supported. This document provides models and technical specifications of some 1GE SFP transceivers for reference. For details about the technical specifications, see *Ruijie Transceiver Installation and Reference Guide*.

Table 6-2 1GE Mini-GBIC (SFP) Models and Technical Specifications

Model	Wavelength (nm)	Fiber Type	DDM Support (Yes/No)	Transmit Power (dBm)		Receive Power (dBm)	
				Min	Max	Min	Max
MINI-GBIC-SX-MM850	850	MMF	Yes	-9	-3	-20	-3
MINI-GBIC-LX-SM1310	1310	SMF	Yes	-9	-3	-26	0
GE-SFP-LH40-SM1310-BIDI	1310TX/1550RX	SMF	Yes	-3	3	-25	0
GE-SFP-LH40-SM1550-BIDI	1550TX/1310RX	SMF	Yes	-3	3	-25	0
GE-SFP-LX20-SM1310-BIDI	1310TX/1550RX	SMF	Yes	-8	-3	-23	-3

Model	Wavelength (nm)	Fiber Type	DDM Supported (Yes/No)	Transmit Power (dBm)		Receive Power (dBm)	
				Min	Max	Min	Max
GE-SFP-LX20-SM1550-BIDI	1550TX/1310RX	SMF	Yes	-8	-3	-23	-3
MINI-GBIC-LH40-SM1310	1310	SMF	Yes	-5	0	-25	-3
MINI-GBIC-ZX80-SM1550	1550	SMF	Yes	-3	3	-26	-3
GE-SFP-LX03-SM1310-BIDI-I	1310TX/1550RX	SMF	Yes	-9	-3	-22	-3
GE-SFP-LX03-SM1550-BIDI-I	1550TX/1310RX	SMF	Yes	-9	-3	-22	-3
SFP-MM850	850	MMF	Yes	-9.5	-3	-17	-3
SFP-SM1310	1310	SMF	Yes	-9	-3	-20	-3

Table 6-3 1GE SFP Copper Transceivers

Standard	1000BASE-T SFP Module	DDM Supported (Yes/No)
1000BASE-T	Mini-GBIC-GT	No

Table 6-4 Cabling Specifications of SFP Transceivers

SFP Transceiver Model	Port Type	Fiber Type	Core Size (μm)	Max Cabling Distance
SFP-SM1310	LC	SMF	9/125	10 km (6.21 miles)
MINI-GBIC-LX-SM1310	LC	SMF	9/125	10 km (6.21 miles)
GE-SFP-LH40-SM1310-BIDI	LC	SMF	9/125	40 km (24.85 miles)
GE-SFP-LH40-SM1550-BIDI	LC	SMF	9/125	40 km (24.85 miles)
GE-SFP-LX20-SM1310-BIDI	LC	SMF	9/125	20 km (12.43 miles)
GE-SFP-LX20-SM1550-BIDI	LC	SMF	9/125	20 km (12.43 miles)

SFP Transceiver Model	Port Type	Fiber Type	Core Size (µm)	Max Cabling Distance
				miles)
MINI-GBIC-LH40-SM1310	LC	SMF	9/125	40 km (24.85 miles)
MINI-GBIC-ZX80-SM1550	LC	SMF	9/125	80 km (49.71 miles)
GE-SFP-LX03-SM1310-BIDI-I	LC	SMF	9/125	3 km (1.86 miles)
GE-SFP-LX03-SM1550-BIDI-I	LC	SMF	9/125	3 km (1.86 miles)
MINI-GBIC-SX-MM850	LC	MMF	62.5/125	275 m (902.23 ft.)
			50/125	550 m (1,804.46 ft.)
SFP-MM850	LC	MMF	62.5/125	275 m (902.23 ft.)
			50/125	550 m (1,804.46 ft.)
Mini-GBIC-GT	RJ45 Ethernet cable	CAT5 or better UTP or STP cable		100 m (328.08 ft.)

⚠ Caution

- For optical transceivers with a cabling distance of no less than 40 km (24.85 miles), install an optical attenuator to avoid overload on an optical receiver when using short-distance SMFs.
- An optical transceiver is a laser transmitter. Do not look into the light source to prevent it from burning your eyes.
- To keep the optical transceiver clean, make sure that the unused ports remain capped.

Table 6-5 BIDI Optical Transceiver Pairing

Rate/Distance	Pairing Model
1000 Mbps/3 km (1.86 miles)	GE-SFP-LX03-SM1310-BIDI-I GE-SFP-LX03-SM1550-BIDI-I
1000 Mbps/20 km (12.43 miles)	GE-SFP-LX20-SM1310-BIDI GE-SFP-LX20-SM1550-BIDI
1000 Mbps/40 km (24.85 miles)	GE-SFP-LH40-SM1310-BIDI GE-SFP-LH40-SM1550-BIDI

⚠ Caution

BIDI optical transceivers must be used in pairs. For example, if GE-SFP-LX20-SM1310-BIDI is used at one end, GE-SFP-LX20-SM1550-BIDI must be used at the other end.

6.3 Lightning Protection

6.3.1 Installing the AC Power Arrester (Power Strip with Surge Protection)

When an alternating current (AC) power cord is introduced from outdoors and directly connected to the AC power port of the switch, the power port must be connected to an external power arrester to safeguard the switch against lightning strikes. The power arrester can be fixed on the rack, workbench, or wall in the equipment room by using cable ties and screws. AC power enters the power arrester before entering the switch.

Figure 6-4 Power Arrester

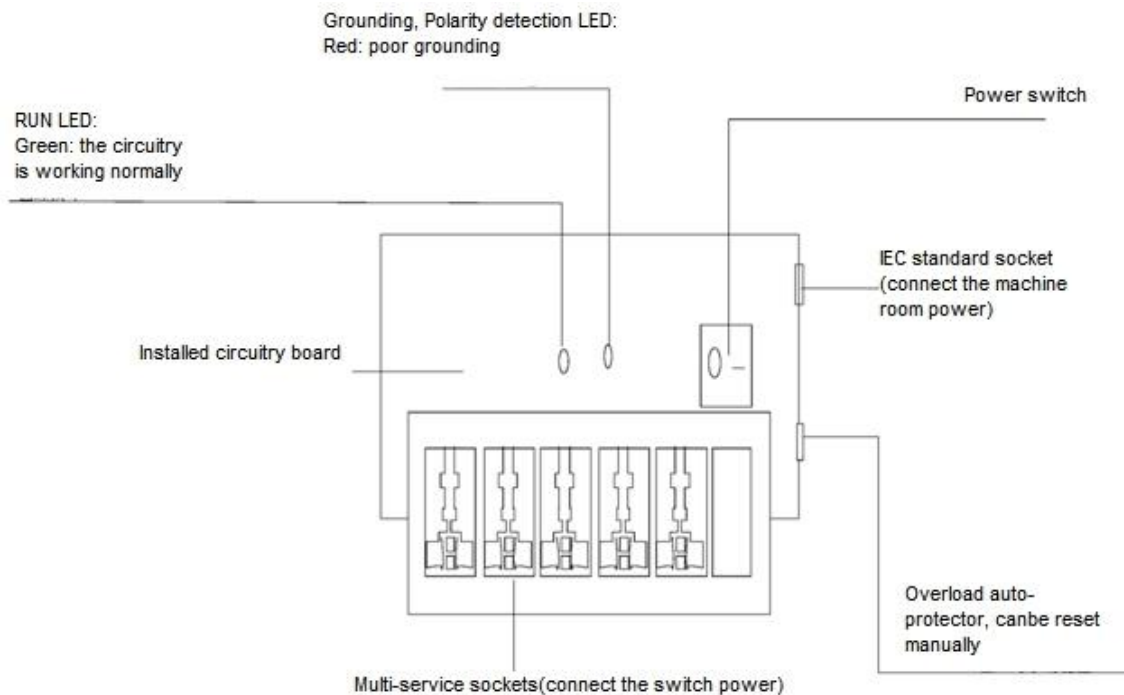

⚠ Caution

The power arrester is not delivered with the equipment. Please purchase it based on actual requirements.

Precautions during the installation:

- Make sure that the PE terminal of the power arrester is well grounded.
- After the AC power plug of the switch is connected to the socket of the power arrester, the lightning protection function is implemented only if the running status LED is green and the alarm LED is off.
- If the alarm LED on the power arrester is red, check whether it is caused by a poor grounding connection or by the reversed connection of the neutral and live wires. The detection method is as follows: Use a multimeter

to measure the polarity of the power arrester when the alarm LED is red. If the neutral wire is on the left and the live wire is on the right (facing the socket), the PE terminal of the power arrester is not grounded. If not, the polarity of the power arrester should be reversed. In this case, open the power arrester and reverse its polarity. If the alarm LED is still red, the PE terminal of the power arrester is not grounded.

6.3.2 Installing the Ethernet Port Arrester

Please connect an Ethernet port arrester to the switch to prevent the damage by lightning strikes before connecting an outdoor Ethernet cable to the switch.

- Tools: Phillips screwdriver or flat-blade screwdriver, multimeter, and diagonal pliers
- Installation steps
 - a Tear one side of the protective paper for the double-sided adhesive tape and paste the tape to the enclosure of the Ethernet port arrester. Tear the other side of the protective paper for the double-sided adhesive tape and paste the Ethernet port arrester to the switch enclosure. The paste position for the Ethernet port arrester should be as close to the grounding lug of the switch as possible.
 - b Based on the distance between the grounding lug of the switch and the Ethernet port arrester, cut the grounding cable of the Ethernet port arrester and firmly tighten the grounding cable to the grounding lug of the switch.
 - c Use a multimeter to check whether the grounding cable for the arrester is in good contact with the grounding lug and the enclosure of the switch.
 - d Connect the Ethernet port arrester by using an adapter cable (note that the external Ethernet cable is connected to the IN end, while the adapter cable connected to the switch is connected to the OUT end) and check whether the module LED is normal.
 - e Use a nylon cable tie to bind the cables.

Figure 6-5 Installing an Ethernet Port Arrester

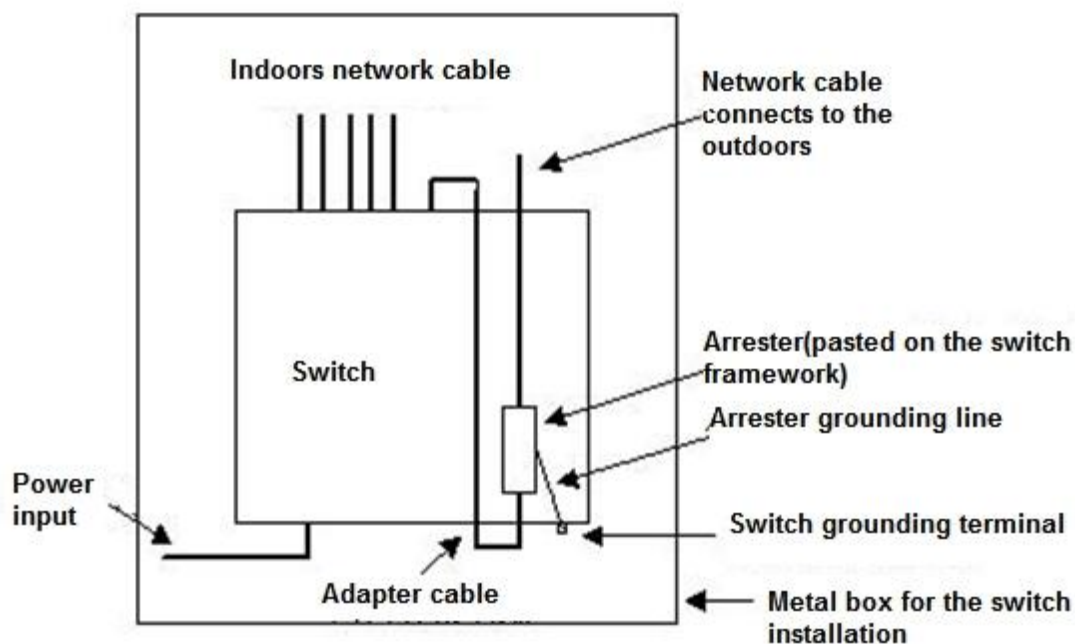

⚠ Caution

- The Ethernet port arrester is only for a 10 Mbps, 100 Mbps, or 1000 Mbps RJ45 port.
 - The Ethernet port arrester is not delivered with the equipment. Please purchase it based on actual requirements. The user manual for Ethernet port arresters contains technical parameters and maintenance and installation instructions. Carefully read this manual during installation.
-

Pay attention to the following situations during the actual installation to avoid influencing the performance of an Ethernet port arrester:

- The arrester is incorrectly connected to the cables. Connect the external Ethernet cable to the IN end and connect the Ethernet port of the switch to the OUT end.
- The Ethernet port arrester is incorrectly grounded. The grounding cable of the arrester should be as short as possible to ensure that it is in good contact with the grounding lug of the switch. Use a multimeter to confirm the contact condition after grounding.
- Not all Ethernet ports are installed with Ethernet port arresters. If outdoor Ethernet cables connect the switch ports to the peer equipment, Ethernet port arresters need to be installed on all the ports for the purpose of lightning protection.

6.4 Recommended Cabling

When the switch is installed in a standard 19-inch cabinet, secure the cables around the cable management brackets. Top cabling or bottom cabling is adopted according to the actual situation in the equipment room. All adapted connectors should be placed at the bottom of the rack in an orderly manner instead of outside the rack that is easy to touch. Power cords are routed beside the rack. Top cabling or bottom cabling is adopted according to the actual situation in the equipment room, such as the positions of the DC power distribution box, AC socket, or lightning protection box.

6.4.1 Requirement for the Minimum Bend Radius of Cables

- The bend radius of a fixed power cord, Ethernet cable, and flat cable should be over five times greater than their respective external diameters. The bend radius of these cables that are often bent or plugged should be over seven times greater than their respective external diameters.
- The bend radius of a fixed common coaxial cable should be over seven times greater than its external diameter. The bend radius of these cables that are often bent or plugged should be over 10 times greater than their respective external diameters.
- The minimum bend radius of a high-speed cable, such as an SFP+ cable, should be 5 times the overall diameter of the cable. If the cable is constantly bent, plugged or unplugged, the bend radius should be 10 times the overall diameter.
- The minimum bend radius of optical cables should meet the following requirements.
 - The diameter of the optical cable tray should be no less than 25 times greater than that of the optical cable.
 - When an optical cable is moved, its bend radius should be no less than 20 times greater than its diameter.
 - During cabling of an optical cable, its bend radius should be no less than 10 times greater than its

diameter.

6.4.2 Precautions for Cable Bundling

- Before cables are bundled, mark labels and stick the labels to cables wherever appropriate.
- Cables should be neatly and properly bundled in the rack without twisting or bending, as shown in [Figure 6-6](#).

Figure 6-6 Bundling Cables (1)

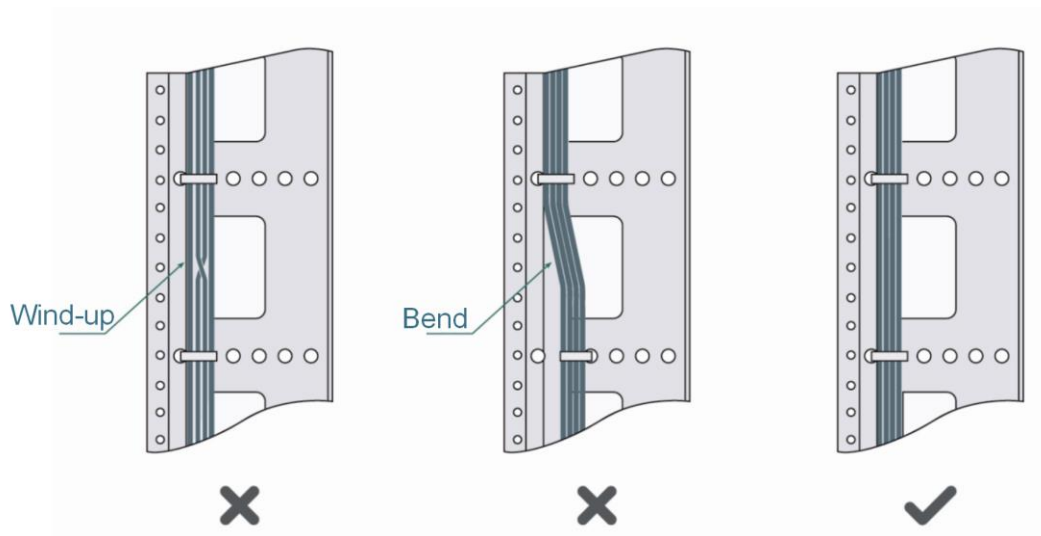

- Cables of different types (such as power cords, signal cables, and grounding wires) should be separated in cabling and bundling. Mixed bundling is not allowed. When they are close to each other, you are advised to adopt crossover cabling. In the case of parallel cabling, maintain a minimum distance of 30 mm (1.18 in.) between power cords and signal cables.
- The cable management brackets and cabling troughs inside and outside the rack should be smooth without sharp corners.
- The metal holes traversed by cables should have a smooth and fully rounded surface or an insulated lining.
- Use cable ties to bundle cables properly. Please do not connect two or more cable ties to bundle cables.
- After bundling up cables with cable ties, cut off the remaining part. The cut should be smooth and trim without sharp corners, as shown in [Figure 6-7](#).

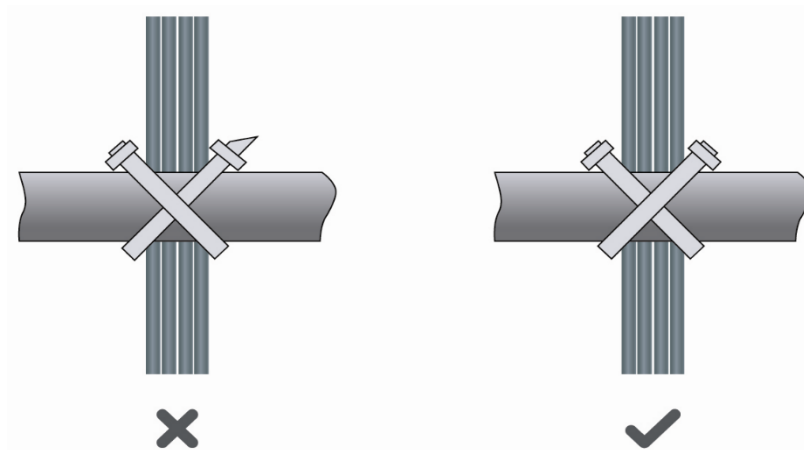
Figure 6-7 Bundling Cables (2)

- When cables need to be bent, bundle them first but do not tie cables within the bend. Otherwise, stress may be generated on the cables and cause the wires inside to break, as shown in [Figure 6-8](#).

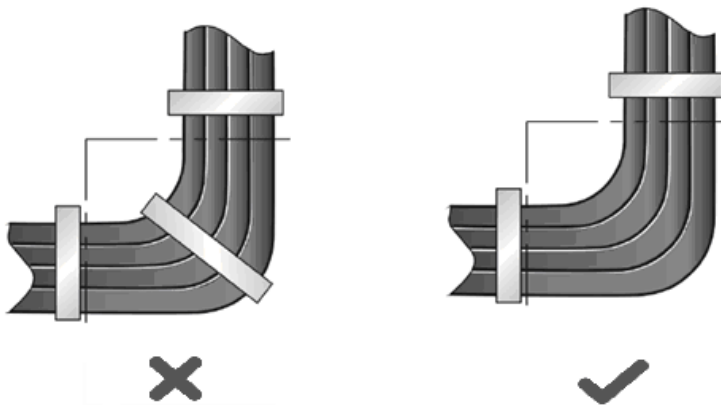
Figure 6-8 Bundling Cables (3)

- Cables not to be assembled or the remaining parts of cables should be folded and placed in a proper position of the rack or cable management trough. The proper position refers to a position that does not affect the equipment running or damage the equipment or cables.
- Power cords must not be bundled on the guide rails of moving parts.
- The power cords connecting moving parts such as door grounding wires should be reserved with some excess after being assembled to avoid suffering tension or stress. When a moving part reaches the installation position, the remaining cable part should not touch heat sources, sharp corners, or sharp edges. If heat sources must be touched, high-temperature cables should be used.
- When using screw threads to secure a cable lug, ensure that the bolt or screw is properly tightened and take measures to prevent it from loosening, as shown in [Figure 6-9](#).

Figure 6-9 Fastening Cables

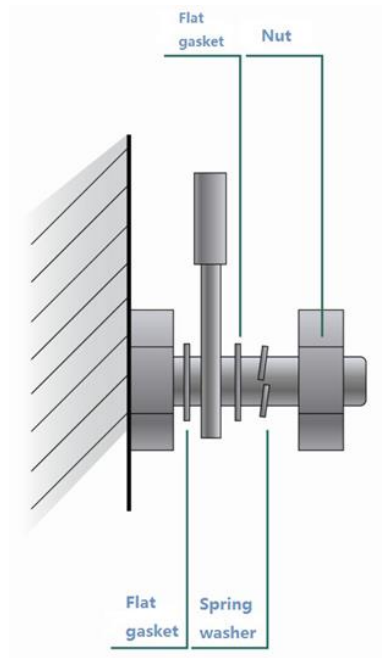

- Hard power cords should be secured near the cable termination area to prevent stress on the cable termination area and cables.
- Do not use tapping screws to secure cable lugs.
- Power cords of the same type and in the same cabling direction should be bundled up into cable bunches, with cables in cable bunches clean and straight.
- Bundle cables by using cable ties according to the following table.

Cable Bunch Diameter	Bundling Spacing
10 mm (0.39 in.)	80–150 mm (3.15–5.91 in.)
10–30 mm (0.39–1.18 in.)	150–200 mm (5.91–7.87 in.)
30 mm (1.18 in.)	200–300 mm (7.87–11.81 in.)

- Do not tie cables or bundles in a knot.
- For wiring terminal blocks (such as circuit breakers) with cord end terminals, the metal part of the cord end terminal should not be exposed outside the terminal block when assembled.

6.5 Site Selection

- The equipment room should be at least 5 km (3.11 miles) away from heavy pollution sources, such as smelters, coal mines, and thermal power plants. The equipment room should be at least 3.7 km (2.30 miles) away from medium pollution sources, such as the chemical factory, rubber factory, and electroplating factory. The equipment room should be at least 2 km (1.24 miles) away from light pollution sources, such as the food factory and leather plant. If the pollution source is unavoidable, the equipment room should be located on

the windward side of the pollution source perennially with advanced protection.

- The equipment room should be at least 3.7 km (2.30 miles) away from the sea or salt lake. Otherwise, the equipment room must be sealed, with an air conditioner installed for temperature control. Saline soil cannot be used for construction. Otherwise, you should select equipment with advanced protection against severe environments.
- Do not build the equipment room in the proximity of livestock farms. Otherwise, the equipment room should be located on the windward side of the pollution source perennially. The previous livestock house or fertilizer warehouse cannot be used as the equipment room.
- The equipment room should be firm enough to withstand severe weather conditions such as windstorms, heavy rain, and dense dust. If the dust is unavoidable, keep the door and window away from the pollution source.
- The equipment falls into Class A. Therefore, the equipment room should be located away from the residential area. Otherwise, the equipment room should meet construction specifications to avoid noise and radio interference.
- Make sure the air vent of the equipment room is away from the sewage pipe, septic tank, and sewage treatment tank. Keep the equipment room under positive pressure to prevent corrosive gas from entering the equipment room to corrode components and circuit boards.
- Keep the equipment room away from industrial boilers and heating boilers.
- The equipment room should be on the second floor or higher. Otherwise, the equipment room floor should be 600 mm (23.62 in.) higher than the highest flood level ever recorded.
- Make sure no cracks or holes exist in the wall and floor. If there are cable entries in the wall or window, take proper sealing measures. Ensure that the wall is flat, wear-resistant, and dust-free, meeting standards for flame resistance, soundproofing, heat absorption, dust reduction, and electromagnetic shielding.
- Keep the door and the window closed to make the equipment room sealed.
- You are advised to use the steel door for soundproofing.
- Do not use sulfur-containing materials.
- Keep the air conditioner from blowing wind straight toward the equipment or blowing water drops from the window or air vent toward the equipment.

Contents

1 Overview	4
1.1 About the RG-ES207GS-LP	4
1.2 Equipment Appearance	4
1.2.1 Front Panel.....	4
1.2.2 Rear Panel	5
1.2.3 LEDs	6
1.3 Cooling.....	7
1.4 Technical Specifications	7
2 Preparing for Installation	10
2.1 Package Contents.....	10
2.2 Safety Guidelines.....	10
2.2.1 General Precautions	10
2.2.2 Chassis-Lifting Guidelines	10
2.2.3 Electricity Safety	11
2.2.4 Preventing ESD Damage.....	12
2.2.5 Laser Safety	12
2.3 Site Requirements	12
2.3.1 Floor Loading	12
2.3.2 Airflow.....	12
2.3.3 Space	13
2.3.4 Temperature and Humidity.....	13
2.3.5 Cleanliness.....	13

2.3.6	Grounding	14
2.3.7	Preventing Electromagnetic Interference	14
2.3.8	Surge Protection	14
2.3.9	Installation Site.....	15
2.4	Tools	15
3	Installing the Switch	16
3.1	Before You Begin.....	16
3.2	Installing the Switch	16
3.2.1	Wall Mount	16
3.2.2	Workbench Mount.....	17
3.3	Grounding the Equipment.....	17
3.4	Connecting Cables.....	18
3.5	Bundling Cables.....	18
3.5.1	Precautions	18
3.5.2	Bundling Procedure	18
3.6	Verifying Installation.....	18
4	Commissioning.....	20
4.1	Power-On.....	20
4.2	Logging In to the Management Interface.....	20
5	Troubleshooting.....	21
5.1	General Troubleshooting Flowchart	21
5.2	Common Faults.....	21
6	Appendix.....	23
6.1	Connectors and Media.....	23

6.1.1 10Or100Or1000BASE-T Port	23
6.1.2 Optical Cable Connection	24
6.2 SFP Transceivers	24
6.3 Lightning Protection	27
6.3.1 Installing the AC Power Arrester (Power Strip with Surge Protection)	27
6.3.2 Installing the Ethernet Port Arrester	28
6.4 Recommended Cabling	29
6.4.1 Requirement for the Minimum Bend Radius of Cables	29
6.4.2 Precautions for Cable Bundling	29
6.5 Site Selection	32

1 Overview

1.1 About the RG-ES207GS-LP

The RG-ES207GS-LP Ethernet switch provides six 10/100/1000BASE-T ports, one 1GE SFP port, one Reset button, and several LEDs on the front panel, along with a 54 V DC power port, a DIP switch, and a grounding stud on the rear panel. Ports 1–4 support Power over Ethernet (PoE) Out.

Figure 1-1 RG-ES207GS-LP Appearance

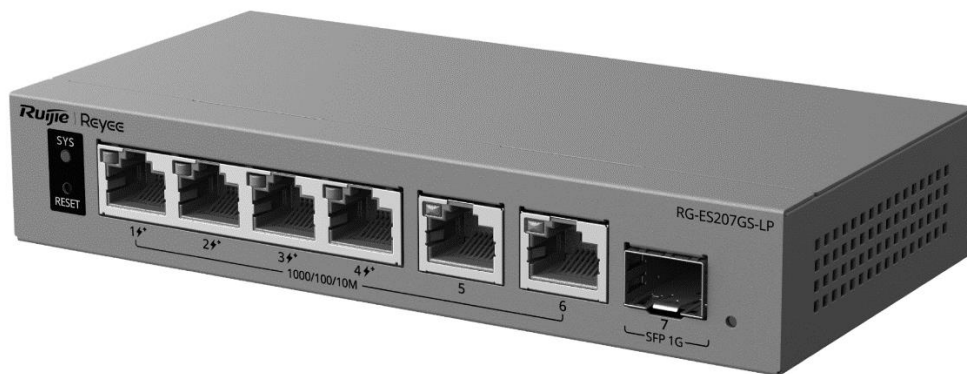

Note

- 1GE SFP port: Supports only 1GE SFP optical transceivers (not compatible with 100 Mbps optical cables).
 - 10/100/1000BASE-T port: Supports auto-negotiation at 10 Mbps, 100 Mbps, and 1000 Mbps.
-

1.2 Equipment Appearance

1.2.1 Front Panel

Figure 1-2 Front Panel of the RG-ES207GS-LP

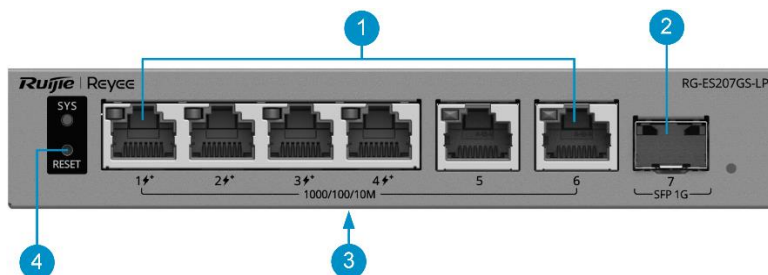

Note

⚡+ indicates the PoE+ ports, which are compliant with IEEE 802.3at, and backward compatible with IEEE 802.3af.

Table 1-1 Components on the Front Panel

No.	Component	Silkscreen	Description
1	RJ45 port	1–6	10/100/1000BASE-T ports, with ports 1–4 supporting PoE Out.
2	SFP port	7	1GE SFP port, supporting 1GE SFP transceiver (hot-swappable)
3	Nameplate	-	It is located at the bottom of the switch.
4	Reset button	RESET	<ul style="list-style-type: none"> Press and hold the button for less than 2 seconds. The switch is reset. Press and hold the button for 2–5 seconds. No action is performed. Press and hold the button for more than 5 seconds, and release the button until the system status LED starts blinking to restore factory settings and restart the switch.

Note

For details about LEDs on the front panel, see "LEDs."

1.2.2 Rear Panel

Figure 1-3 Rear Panel of the RG-ES207GS-LP

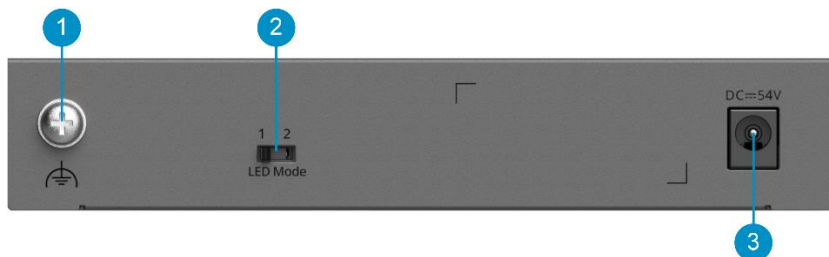

Table 1-2 Components on the Rear Panel

No.	Component	Description
1	Grounding stud	It is connected to a grounding wire.
2	DIP switch	Toggle the DIP switch to change the LED modes of ports 1–4. <ul style="list-style-type: none"> LED mode 1 (switching mode): When the DIP switch is toggled to the left, the port LEDs display the data transmission status. LED mode 2 (PoE mode): When the switch is toggled to the right, the port LEDs display the PoE status.

No.	Component	Description
3	DC power port	It is connected to a 54 V DC power source to supply power to the switch. The matching DC power connector has an outer diameter of 5.5 mm (0.22 in.), an inner diameter of 2.1 mm (0.08 in.), and a depth of 10 mm (0.39 in.).

1.2.3 LEDs

Figure 1-4 RG-ES207GS-LP LEDs

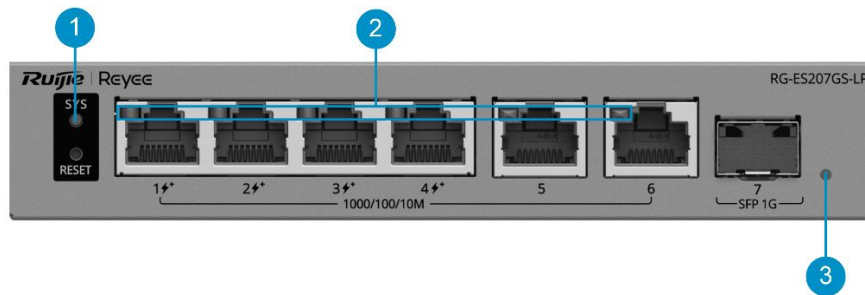

Table 1-3 LEDs

No.	Component	Silkscreen	Description
1	System status LED	SYS	<ul style="list-style-type: none"> ● Off: The switch is not powered on. ● Slow blinking green (0.5 Hz): The switch is operating normally but is not connected to Ruijie Cloud. ● Fast blinking green (10 Hz): The switch is upgrading or restarting, and is temporarily unavailable. ● Solid green: The switch is operating normally and connected to Ruijie Cloud. ● Slow blinking yellow (0.5 Hz): The PoE power is insufficient. ● Slow blinking red (0.5 Hz): A loop occurs on the switch with loop guard enabled.
2	RJ45 port LED	-	<p>LEDs of ports 1–4 support switching mode and PoE mode, which can be switched by toggling the DIP switch on the rear of the switch. LEDs of ports 5 and 6 support only switching mode.</p> <ul style="list-style-type: none"> ● Switching mode: <ul style="list-style-type: none"> ○ Off: The port is not connected. ○ Solid green: The port is operating at 1000 Mbps, 100 Mbps, or 10 Mbps, but is not receiving or sending data. ○ Blinking green: The port is operating at 1000 Mbps, 100 Mbps, or 10 Mbps, and is receiving or sending data. ● PoE mode: <ul style="list-style-type: none"> ○ Off: PoE is disabled on the port. ○ Solid green: PoE is enabled on the port. ○ Blinking green: PoE overload occurs on the port.

No.	Component	Silkscreen	Description
3	SFP port LED	-	<ul style="list-style-type: none"> ● Off: The port is not connected. ● Solid green: The port is operating at 1000 Mbps, but is not receiving or sending data. ● Blinking green: The port is operating at 1000 Mbps, and is receiving or sending data.

1.3 Cooling

The RG-ES207GS-LP adopts fanless design and uses natural cooling. To ensure that the equipment works properly in the specified environment, a minimum clearance of 10 cm (3.94 in.) must be maintained around the equipment for air circulation and ventilation.

1.4 Technical Specifications

Warning

- This equipment is not suitable for use in locations where children are likely to be present.
- Operation of this equipment in a residential environment could cause radio interference.

Table 1-4 Technical Specifications

Parameter Type	Parameter Name	RG-ES207GS-LP
System Specifications	Forwarding rate	10.41 Mpps
	Switching capacity	14 Gbps(bit/s)
	Flash memory	8 MB
Port Specifications	Total number of optical ports	1
	Total number of RJ45 ports	6
	Number of 10/100/1000BASE-T ports	6
	Number of 1GE SFP ports	1
	Reset button	1
	LEDs	1 x system status LED 6 x Ethernet port LEDs 1 x SFP port LED
	DIP switch	LED mode switch toggled to left (Mode 1): The port LED status indicates the status of traffic

Parameter Type	Parameter Name	RG-ES207GS-LP
		<p>transmission. Solid green means that the port is link up, while blinking green means that the port is transmitting and receiving data.</p> <p>LED mode switch toggled to right (Mode 2): The port LED status indicates the PoE status. Solid green means that the port is supplying power, while blinking green means that the port is in power overload state.</p>
Power Supply and Consumption	Power supply	<ul style="list-style-type: none"> ● DC power adapter
	Power input	<p>DC adapter:</p> <ul style="list-style-type: none"> ● Rated input voltage: 100 V AC to 240 V AC, 50 Hz to 60 Hz ● Maximum input voltage: 90 V AC to 264 V AC, 47 Hz to 63 Hz ● Rated input current: 1.5 A <p>Output :</p> <ul style="list-style-type: none"> ● Rated output voltage: 54 V DC ● Maximum output current: 1.2 A
	Maximum power consumption	<p>4 W (with no PoE load)</p> <p>44 W (with full PoE load)</p>
	Number of PoE Out ports	4
	Number of PoE/PoE+ Out ports	4
	PoE Out standard	PoE/PoE+ (IEEE 802.3af/at)
	PoE power pins	1–2 (+), 3–6 (-)
	PoE budget per port	30 W
	PoE budget	40 W
Dimensions and Weight	Product dimensions (W x D x H)	<p>155mm x 78mm x 28mm</p> <p>(6.10 in. x 3.07 in. x 1.10 in.)</p>
	Weight	0.29 kg (0.64 lbs) (without packaging materials)
	Shipping weight	1.12 kg (2.47 lbs)
	Casing	Metal
Interface	EEE	Yes

Parameter Type	Parameter Name	RG-ES207GS-LP
Environment and Reliability	Mounting options	Wall/Desk
	Hot swapping of cables	Hot swapping supported by the service port and power connector
	Fan	Fanless design
	Cooling	Natural cooling
	MTBF	200,000 hours
	ESD protection	Air discharge: 8 kV Contact discharge: 6 kV
	Surge protection	Service port: ± 6 kV for common mode Power connector: ± 4 kV for common mode and ± 2 kV for differential mode
	Operating temperature	0°C to +40°C (32°F to 104°F)
	Storage temperature	-40°C to +70°C (-40°F to +158°F)
	Operating humidity	10% RH to 90% RH (non-condensing)
	Storage humidity	5% RH to 95% RH (non-condensing)
Altitude	-500 m to +5,000 m (-1,640.42 ft. to +16,404.20 ft.)	
Certification and Regulatory Compliance	EMC	EN 55032 EN 61000-3-2 EN 61000-3-3 EN 55035 EN 300 386
	Safety compliance	EN 62368-1 IEC 62368-1
	Certification	CE,CB

2 Preparing for Installation

2.1 Package Contents

Table 2-1 Package Contents

No.	Item	Quantity
1	RG-ES207GS-LP switch	1
2	User Manual	1
3	Warranty Card	1
4	Power adapter	1
5	Power cord	1

Note

The package contents are subject to the purchase contract, and actual delivery may vary. Please check the items carefully against the package contents or purchase contract. If you have any questions, please contact the distributor.

2.2 Safety Guidelines

Note

- To avoid personal injury or equipment damage, review the safety guidelines in this chapter before you begin the installation.
 - The following safety guidelines may not include all the potentially hazardous situations.
-

2.2.1 General Precautions

- Never operate the equipment in a wet environment, and avoid any liquids inside it. Keep the chassis clean and dust-free.
- Keep the equipment away from heat sources.
- Keep the equipment away from walk areas.
- During installation and maintenance, do not wear loose clothing or ornament that may get caught in the chassis.
- Keep tools and accessories away from walk areas.

2.2.2 Chassis-Lifting Guidelines

- Avoid moving the equipment frequently.
- Turn off all power supplies and disconnect all cables before lifting or moving the equipment.

2.2.3 Electricity Safety

Warning

- Any deviation from standard or improper electrical operations can result in accidents such as fires or electric shocks, potentially causing severe or even fatal harm to both individuals and equipment.
 - Direct or indirect touch through a wet object on high-voltage and mains supply can bring a fatal danger.
-

- Always observe the local regulations and standards. Only qualified personnel should be allowed to operate the equipment.
- Carefully check the work area for potential hazards, including ungrounded power system, absent safety grounds, and damp floors.
- Locate the emergency power-off switch in the room before installation. In the case of an accident, cut off the power supply immediately.
- Never assume that power is connected to or disconnected from a circuit. Always check.
- Select the right leakage protector (also called "leakage current switch" or "leakage current breaker") for the power supply system. This equipment automatically disconnects the power supply in the event of leakage and the risk of electric shock. A leakage protector should meet the following requirements:
 - The rated leakage action current of each leakage protector must be at least twice the total maximum leakage current of all connected power supplies.

Example:

If a system has 16 identical power supplies, each with a maximum leakage current of 3.5 mA:

Total leakage current = $16 \times 3.5 \text{ mA} = 56 \text{ mA}$

For a 30 mA leakage protector:

Maximum number of power supplies per protector = $30 \text{ mA} / 3.5 \text{ mA} \approx 4$

Therefore, only four power supplies can be connected to one 30 mA leakage protector.

To support 16 power supplies, at least four 30 mA leakage protectors are required.

Always ensure:

Rated leakage operating current/2 > Total maximum leakage current of connected power supplies

- The rated leakage non-action current of a leakage protector should be 50% of the leakage action current. If the non-action current value is too small, the high sensitivity level can cause the circuit to break, leading to power cutoff and service interruption, even if the leakage current value is normal.

For example, if a leakage protector has a rated leakage action current of 30 mA, the rated leakage non-action current should be 15 mA. The leakage protector will not activate unless the leakage current exceeds 15 mA.

Caution

- To ensure personal safety, each leakage protector in the system must have a rated leakage action current equal to or below 30 mA, which is the recognized safety threshold for human body current. If the total leakage current of the system exceeds twice the 30 mA limit, the system must be equipped with two or more leakage protectors to maintain safety.
 - The leakage current values vary with equipment. For the leakage current value of each equipment model, see "Technical Specifications."
-

2.2.4 Preventing ESD Damage

- Ensure that the chassis is connected to earth ground.
- Keep the site as dust free as possible.
- Maintain appropriate humidity conditions.
- Before installing any pluggable modules, wear an anti-ESD wrist strap and make sure that it is properly grounded.
- Avoid contact between the printed circuit boards and clothing. The anti-ESD wrist strap only protects the printed circuit boards from ESD voltages on the body. ESD voltages on clothing can still cause damage.

2.2.5 Laser Safety

The equipment supports various types of optical transceivers, which are Class 1 laser products.

Precautions:

- When an optical transceiver is working, ensure that its port is connected to an optical cable or covered by a dust cap to keep out dust and prevent it from burning your eyes.
- Do not stare into an optical port.

Figure 2-1 Laser Product ID



Caution

Do not approach or stare into an optical port under any circumstances. This may cause permanent damage to your eyes.

2.3 Site Requirements

The equipment must be installed indoors for normal operation and prolonged service life.

The installation site must meet the following requirements.

2.3.1 Floor Loading

Assess the combined weight of the equipment and its accessories, such as chassis and power modules, and verify that the floor under the rack can bear the weight.

2.3.2 Airflow

The equipment adopts natural cooling. Reserve a sufficient clearance around the equipment to ensure proper ventilation.

2.3.3 Space

Do not install the equipment against a wall. Instead, maintain a minimum clearance of 10 cm (3.94 in.) around the equipment for heat dissipation and equipment maintenance.

2.3.4 Temperature and Humidity

To ensure the normal operation and a prolonged service life of the equipment, maintain an appropriate temperature and humidity in the installation environment.

Prolonged exposure to inappropriate temperature and humidity conditions can cause damage to the equipment.

- In an environment with high relative humidity, insulating materials are prone to poor insulation or even electricity leakage.
- In an environment with low relative humidity, insulating gaskets may shrink, resulting in screw loosening.
- In a dry environment, static electricity is more likely to occur, posing a risk to the internal circuits of equipment.
- A high temperature can accelerate the aging process of insulation materials, greatly reducing the availability of the equipment and severely affecting its service life.

2.3.5 Cleanliness

Dust poses a significant hazard to the equipment. Dust on the enclosure causes electrostatic adhesion, leading to poor contact of the metallic joints. Electrostatic adhesion is more likely to occur in an indoor environment with relatively low humidity, not only affecting the service life of the equipment, but also causing communication faults. The following table lists the requirements for dust concentration and particle size in the equipment room.

Table 2-2 Requirements for Dust

Particle Diameter	Unit	Concentration
≥ 0.5 μm	Particles/m ³	≤ 3.5 × 10 ⁶
≥ 5 μm	Particles/m ³	≤ 3.5 × 10 ⁶

Apart from dust, there are also requirements on the salt, acid, and sulfide in the air of the equipment room. These harmful substances will accelerate metal corrosion and component aging. Therefore, the equipment room should be properly protected against harmful gases, such as sulfur dioxide, hydrogen sulfide, nitrogen dioxide, and chlorine gas. The following table lists the limits on harmful gases.

Table 2-3 Requirements for Gases

Gas	Average (mg/m ³)	Maximum (mg/m ³)
Sulfur dioxide (SO ₂)	0.3	1.0
Hydrogen sulfide (H ₂ S)	0.1	0.5
Nitrogen dioxide (NO ₂)	0.5	1.0
Chlorine gas (Cl ₂)	0.1	0.3

Note

Average refers to the average value of harmful gases measured in a week. **Maximum** refers to the upper limit of harmful gases measured in a week for up to 30 minutes every day.

2.3.6 Grounding

A proper grounding system is crucial for ensuring stable and reliable operation, as well as preventing lightning strikes and interference. Carefully check the grounding conditions at the installation site according to the grounding requirements, and complete grounding properly based on the site situation.

- Safety Grounding

Ensure that the power distribution system is securely grounded if the equipment uses the AC power supply. Otherwise, electric shocks may occur when the insulation resistance between the power module and the chassis decreases.

Caution

- The building should provide a protective ground connection to ensure that the equipment is connected to a protective ground.
 - Verify that the AC socket is reliably connected to the protective grounding system of the building. If not, a protective grounding wire should be used to connect the protective grounding lug of the AC socket to the protective grounding system of the building.
-

- Lightning Grounding

The lightning protection system is an independent system composed of a lightning rod, a downlead conductor, and a connector connected to the grounding system. The grounding system is typically used for power reference grounding and safety grounding. Lightning grounding is required only for facilities, and is not required for the equipment.

- EMC Grounding

Electromagnetic compatibility (EMC) grounding includes shielded grounding, filter grounding, noise and interference suppression, and level reference.

2.3.7 Preventing Electromagnetic Interference

- Take interference prevention measures for the power supply system.
- Keep the equipment away from the grounding system or lightning protection grounding system of the power facility.
- Keep the equipment far away from high-frequency current equipment such as high-power radio transmitting stations and radar launchers.
- Take electromagnetic shielding measures when necessary.

2.3.8 Surge Protection

Although the equipment can guard against lightning strikes, strong lightning strikes may still damage the equipment. Take the following surge protection measures:

- Ensure that the grounding wire is in good contact with the ground.

- Ensure that the neutral point of the AC power socket is in good contact with the ground.
- Install a power arrester in front of the power input end to enhance surge protection for the power supply.

2.3.9 Installation Site

Regardless of whether the equipment is installed on a wall or a workbench, ensure that the following conditions are met:

- Maintain a proper clearance around the equipment for heat dissipation.
- Alternatively, place the equipment on a clean workbench. The installation of air conditioners is recommended in hot areas.

2.4 Tools

Table 2-4 Tools

Common Tools	Phillips screwdriver, cables, cage nuts, diagonal pliers, cable ties, and grounding wires
Dedicated Tools	Anti-ESD gloves, wire stripper, crimping pliers, RJ45 crimping pliers, and wire cutter
Meter	Multimeter

 **Note**

The equipment is delivered without a toolkit. Prepare the preceding tools by yourself.

3 Installing the Switch

⚠ Caution

Before installing the equipment, ensure that guidelines and requirements in Chapter 2 have been met.

3.1 Before You Begin

- The installation site provides sufficient space for heat dissipation.
- The installation site meets the temperature and humidity requirements.
- The power supply is available at the installation site, and its current meets the requirements.
- The Ethernet cables have been deployed at the installation site.
- Locate the emergency power-off switch in the room before installation. In the case of an accident, cut off the power supply immediately.

3.2 Installing the Switch

3.2.1 Wall Mount

i Note

- You need to prepare two M3 screws and two plastic expansion anchors for wall mounting.
 - For wall mounting, install the equipment only on concrete or other non-flammable surfaces.
-

The steps for wall mounting a switch are as follows:

- (1) Drill two holes at suitable positions on the wall with a spacing of 112.6 mm (4.43 in.). The hole diameter and depth depend on the specifications of the purchased plastic expansion anchors.
- (2) Insert two plastic expansion anchors into the drilled holes, and then screw two M3 screws into the plastic expansion anchors.

i Note

- Ensure that the distance between the inner side of the screw heads and the outer edge of the plastic expansion anchors is at least 2.5 mm (0.1 in.) to securely mount the equipment onto the screws.
 - The equipment appearance shown in the installation diagram is for reference only.
-

- (3) Mount the equipment on the two M3 screws, as shown in the following figure.

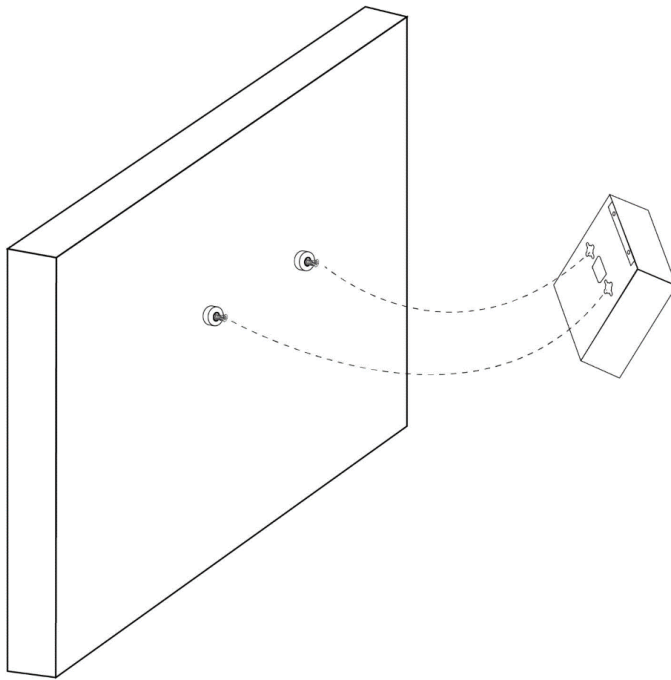
Figure 3-1 Mounting the Switch on a Wall

3.2.2 Workbench Mount

If wall mounting is not feasible, place the switch on a clean workbench and choose a location where it is unlikely to be touched, to ensure the safety and stability of the switch.

3.3 Grounding the Equipment

Note

- If the equipment is installed on a workbench, connect the grounding wire to the nearest grounding bar or grounding point based on the onsite situation.
 - The grounding wire is not delivered with the equipment and needs to be purchased by the customer.
-

The equipment has a grounding stud on the rear panel. You are advised to connect the system grounding wire to it before using the equipment.

- (1) Purchase a grounding wire and connect one end to the grounding stud at the rear of the equipment.
 - (2) Connect the other end of the grounding wire to the nearest grounding bar or grounding point.
-

Caution

- To avoid personal injury and equipment damage, connect the switch to earth ground properly. The grounding resistance between the chassis and the ground should be less than 1 ohm.
 - The O&M personnel should verify whether the AC socket is reliably connected to the protective ground of the building. If not, the O&M personnel should use a protective grounding wire to connect the protective grounding lug of the AC socket to the protective ground of the building.
 - The power socket should be installed near the equipment and easily accessible.
 - During the equipment installation, connect the grounding wire first and disconnect it last.
-

- The sectional area of a grounding wire should be determined according to the possible maximum current. Grounding wires with good conductors should be used.
 - Do not use bare wires.
-

3.4 Connecting Cables

Caution

- All cables must be routed indoors. Take surge protection measures if they need to be routed outdoors.
 - When connecting an optical cable, connect the transmit (TX) port on the local equipment to the receive (RX) port on the peer equipment, and vice versa.
-

After the switch is installed, connect the switch to other equipment according to the following steps:

- (1) Connect the power cord delivered with the switch to the power strip.
- (2) Connect the RJ45 connector of a twisted pair to an Ethernet port on the switch, and the other end to downlink equipment.
- (3) Insert an optical transceiver into the optical port first according to the panel identification. Then connect a single-mode fiber (SMF) or multimode fiber (MMF) to the corresponding optical transceiver, during which the transmitting and receiving ends of the optical cable should be distinguished.

3.5 Bundling Cables

3.5.1 Precautions

- Bundle the power cord and other cables in an esthetically pleasing way.
- Make sure that the optical cables at the connectors have natural bends or bends of large radius.
- Do not bind optical cables and twisted pairs too tightly, as this may press the cables and affect their service life and transmission performance.

3.5.2 Bundling Procedure

- (1) Bind the drooping part of the optical cables and twisted pairs, and lead them to both sides of the chassis for convenience.
- (2) Bind the power cord closely along the bottom of the chassis, in a straight line wherever possible.

3.6 Verifying Installation

Caution

Please turn off the power to avoid personal injury and damage to components caused by incorrect connection.

- Verify that the grounding wire is connected.
- Verify that the cables including power cords are properly connected.
- Verify that cables connected to ports are routed indoors.

- Verify that the surge protection socket and Ethernet port arrester are installed, if outdoor cabling exists.
- Verify that there is a minimum clearance of 10 cm (3.94 in.) around the switch.

4 Commissioning

4.1 Power-On

- (1) Checklist Before Power-on
 - The switch is properly grounded.
 - The power cord is properly connected.
 - The power supply voltage meets the requirement of the switch.
- (2) Checklist After Power-on (Recommended)
 - The switch LEDs are in the normal state.
 - Service ports can forward data properly.

4.2 Logging In to the Management Interface

- (1) Connect a PC to an Ethernet port on the switch through an Ethernet cable.
- (2) Set the IP address of the PC to 10.44.77.XXX (Range: 1–254, excluding 200).

Figure 4-1 Changing the IP Address

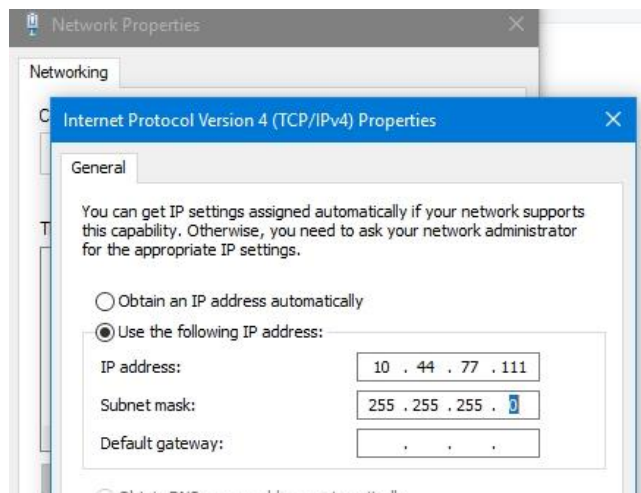

- (3) Open a browser, enter 10.44.77.200 in the address bar, and press Enter. On the login page, set a password and log in.
- (4) Perform equipment commissioning and configuration based on service requirements.

Note

For security purposes, you are advised to change the password regularly.

5 Troubleshooting

5.1 General Troubleshooting Flowchart

Note

You can determine whether each checking item in the process is normal based on the information provided in the previous chapters "Overview" and "Installing the Switch."

Figure 5-1 General Troubleshooting Flowchart

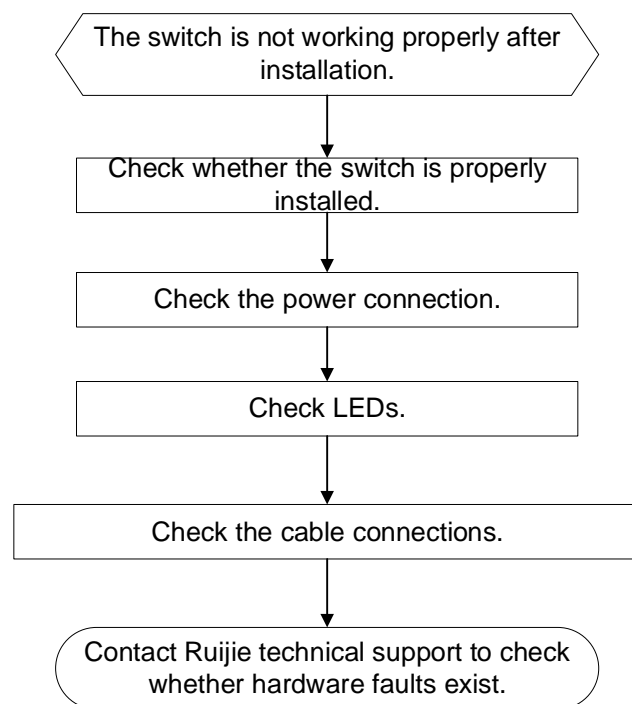

5.2 Common Faults

Table 5-1 Common Faults and Troubleshooting

Symptom	Possible Cause	Suggested Action
The system status LED is off after the switch is powered on.	No power is supplied to the switch or the power cord is loosely connected.	Check whether the power socket in the equipment room is normal and whether the power cord is loosely connected to the switch.
An RJ45 port is disconnected or a frame	The twisted pair is not connected properly.	Replace the twisted pair.

Symptom	Possible Cause	Suggested Action
sending/receiving error occurs.	The cable length exceeds 100 m (328.08 ft.).	Use an optical cable for data transmission or connect to an intermediate switch for relay.
	The port is specially configured and does not work in the same mode as that of the interconnected switch.	Check whether the port is configured to work in the same mode as that of the interconnected switch.
An optical port is not reachable.	The transmit and receive ends are connected incorrectly.	Exchange the transmit and receive ends of the optical cable.
	The types of the interconnected optical transceivers do not match.	Replace with one compatible optical transceiver.
	The optical cable type does not meet the requirements.	Replace the optical cable with a qualified one.
	The optical cable length is beyond the allowed length marked on the optical transceiver.	Use an optical cable with the required length.
	The optical cable or connector is contaminated.	Clean the connector with a lint-free cloth or a cleaning pen.
The login password cannot be retrieved.	The password is forgotten, and the equipment is not connected to the network or Ruijie Cloud.	Press and hold the Reset button to restore to factory settings.
	If the equipment is connected to Ruijie Cloud or a network, its login password is updated to the project or global management password.	If the equipment is connected to the cloud, log in using the project management password. If the equipment is connected to a network, log in using the global management password.
The Ethernet ports are transmitting and receiving frames normally, but their LEDs are off.	<p>The status of the Ethernet port LEDs is incorrectly displayed.</p> <p>The DIP switch is set to LED mode 2. As a result, the Ethernet port LEDs display the PoE status, but PoE is disabled on the ports.</p>	Set the DIP switch to LED mode 1 so that the Ethernet port LEDs display the data receiving and sending status.

6 Appendix

6.1 Connectors and Media

6.1.1 100r100Or1000BASE-T Port

The 10/100/1000BASE-T port supports auto-negotiation for 10 Mbps, 100 Mbps, and 1000 Mbps connections and also supports auto MDI/MDIX Crossover.

Compliant with IEEE 802.3ab, a 1000BASE-T port connects to a 100-ohm Category 5 (CAT5) or Category 5 Enhanced (CAT5e) Unshielded Twisted Pair (UTP), or recommended Shielded Twisted Pair (STP) cable with a maximum distance of 100 m (328.08 ft.).

The 1000BASE-T port requires that all four pairs of wires be connected for data transmission. [Figure 6-1](#) shows twisted pair connections for the 1000BASE-T port.

Figure 6-1 Twisted Pair Connections for a 1000BASE-T Port

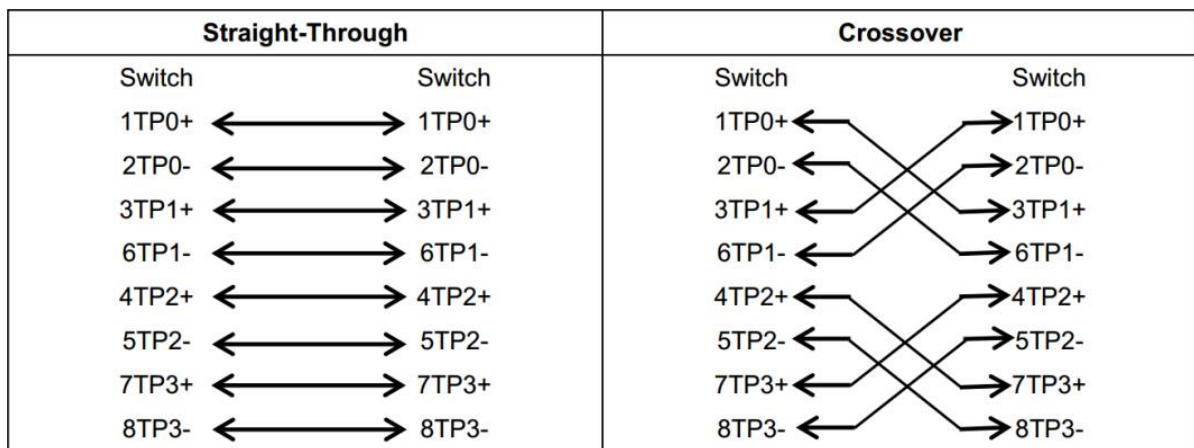

In addition to cables with the above-mentioned specifications, the 10/100BASE-T port can also be connected using 100-ohm CAT3, CAT4, and CAT5 cables at 10 Mbps or using 100-ohm CAT5 cables with a maximum distance of 100 m (328.08 ft.). The following table shows pin assignments for a 10/100BASE-T port.

Table 6-1 10/100BASE-T Pin Assignment

Pin	Socket	Plug
1	Input Receive Data+	Output Transmit Data+
2	Input Receive Data-	Output Transmit Data-
3	Output Transmit Data+	Input Receive Data+
6	Output Transmit Data-	Input Receive Data-
4, 5, 7, and 8	Not Used	Not Used

The following table shows wiring of straight-through and crossover cables for a 10/100BASE-T port.

Figure 6-2 Twisted Pair Connections for a 10/100BASE-T Port

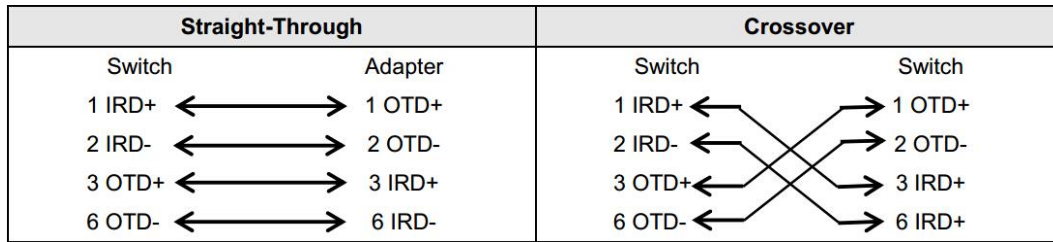

6.1.2 Optical Cable Connection

Select a single-mode fiber (SMF) or multimode fiber (MMF) for connections based on the type of the optical transceiver inserted into an optical port. [Figure 6-3](#) shows the connections.

Figure 6-3 Connecting the Optical Cables

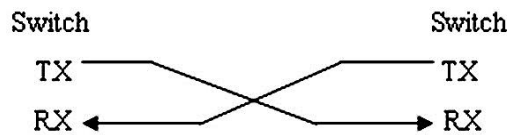

6.2 SFP Transceivers

Ruijie provides SFP transceivers (mini-GBIC) based on the port types. You can select one that suits your specific needs. In addition to the following 1GE SFP transceivers, the 1GE copper transceiver Mini-GBIC-GT is also supported. This document provides models and technical specifications of some 1GE SFP transceivers for reference. For details about the technical specifications, see *Ruijie Transceiver Installation and Reference Guide*.

Table 6-2 1GE Mini-GBIC (SFP) Models and Technical Specifications

Model	Wavelength (nm)	Fiber Type	DDM Supported (Yes/No)	Transmit Power (dBm)		Receive Power (dBm)	
				Min	Max	Min	Max
MINI-GBIC-SX-MM850	850	MMF	Yes	-9	-3	-20	-3
MINI-GBIC-LX-SM1310	1310	SMF	Yes	-9	-3	-26	0
GE-SFP-LH40-SM1310-BIDI	1310TX/1550RX	SMF	Yes	-3	3	-25	0
GE-SFP-LH40-SM1550-BIDI	1550TX/1310RX	SMF	Yes	-3	3	-25	0

Model	Wavelength (nm)	Fiber Type	DDM Supported (Yes/No)	Transmit Power (dBm)		Receive Power (dBm)	
				Min	Max	Min	Max
GE-SFP-LX20-SM1310-BIDI	1310TX/1550RX	SMF	Yes	-8	-3	-23	-3
GE-SFP-LX20-SM1550-BIDI	1550TX/1310RX	SMF	Yes	-8	-3	-23	-3
MINI-GBIC-LH40-SM1310	1310	SMF	Yes	-5	0	-25	-3
MINI-GBIC-ZX80-SM1550	1550	SMF	Yes	-3	3	-26	-3
GE-SFP-LX03-SM1310-BIDI-I	1310TX/1550RX	SMF	Yes	-9	-3	-22	-3
GE-SFP-LX03-SM1550-BIDI-I	1550TX/1310RX	SMF	Yes	-9	-3	-22	-3
SFP-MM850	850	MMF	Yes	-9.5	-3	-17	-3
SFP-SM1310	1310	SMF	Yes	-9	-3	-20	-3

Table 6-3 1GE SFP Copper Transceivers

Standard	1000BASE-T SFP Module	DDM Supported (Yes/No)
1000BASE-T	Mini-GBIC-GT	No

Table 6-4 Cabling Specifications of SFP Transceivers

SFP Transceiver Model	Port Type	Fiber Type	Core Size (μm)	Max Cabling Distance
SFP-SM1310	LC	SMF	9/125	10 km (6.21 miles)
MINI-GBIC-LX-SM1310	LC	SMF	9/125	10 km (6.21 miles)
GE-SFP-LH40-SM1310-BIDI	LC	SMF	9/125	40 km (24.85 miles)
GE-SFP-LH40-SM1550-BIDI	LC	SMF	9/125	40 km (24.85 miles)
GE-SFP-LX20-SM1310-BIDI	LC	SMF	9/125	20 km (12.43 miles)
GE-SFP-LX20-SM1550-BIDI	LC	SMF	9/125	20 km (12.43 miles)
MINI-GBIC-LH40-SM1310	LC	SMF	9/125	40 km (24.85 miles)
MINI-GBIC-ZX80-SM1550	LC	SMF	9/125	80 km (49.71 miles)

SFP Transceiver Model	Port Type	Fiber Type	Core Size (µm)	Max Cabling Distance
GE-SFP-LX03-SM1310-BIDI-I	LC	SMF	9/125	3 km (1.86 miles)
GE-SFP-LX03-SM1550-BIDI-I	LC	SMF	9/125	3 km (1.86 miles)
MINI-GBIC-SX-MM850	LC	MMF	62.5/125	275 m (902.23 ft.)
			50/125	550 m (1,804.46 ft.)
SFP-MM850	LC	MMF	62.5/125	275 m (902.23 ft.)
			50/125	550 m (1,804.46 ft.)
Mini-GBIC-GT	RJ45 Ethernet cable	CAT5 or better UTP or STP cable		100 m (328.08 ft.)

⚠ Caution

- For optical transceivers with a cabling distance of no less than 40 km (24.85 miles), install an optical attenuator to avoid overload on an optical receiver when using short-distance SMFs.
- An optical transceiver is a laser transmitter. Do not look into the light source to prevent it from burning your eyes.
- To keep the optical transceiver clean, make sure that the unused ports remain capped.

Table 6-5 BIDI Optical Transceiver Pairing

Rate/Distance	Pairing Model
1000 Mbps/3 km (1.86 miles)	GE-SFP-LX03-SM1310-BIDI-I GE-SFP-LX03-SM1550-BIDI-I
1000 Mbps/20 km (12.43 miles)	GE-SFP-LX20-SM1310-BIDI GE-SFP-LX20-SM1550-BIDI
1000 Mbps/40 km (24.85 miles)	GE-SFP-LH40-SM1310-BIDI GE-SFP-LH40-SM1550-BIDI

⚠ Caution

BIDI optical transceivers must be used in pairs. For example, if GE-SFP-LX20-SM1310-BIDI is used at one end, GE-SFP-LX20-SM1550-BIDI must be used at the other end.

6.3 Lightning Protection

6.3.1 Installing the AC Power Arrester (Power Strip with Surge Protection)

When an alternating current (AC) power cord is introduced from outdoors and directly connected to the AC power port of the switch, the power port must be connected to an external power arrester to safeguard the switch against lightning strikes. The power arrester can be fixed on the rack, workbench, or wall in the equipment room by using cable ties and screws. AC power enters the power arrester before entering the switch.

Figure 6-4 Power Arrester

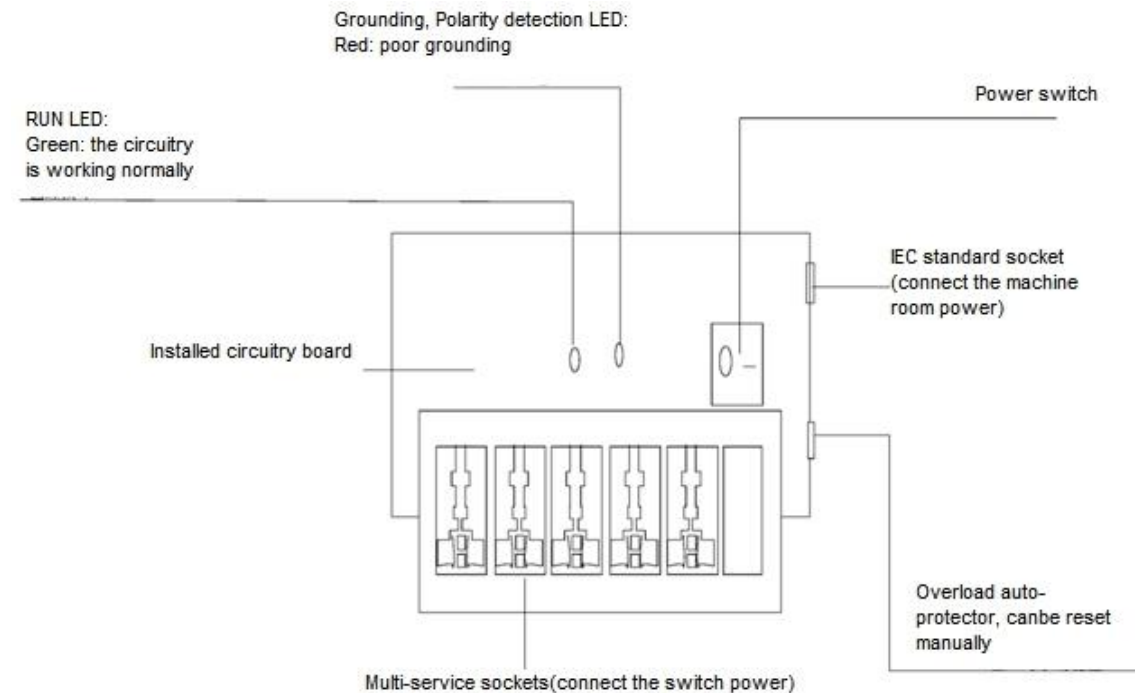

Caution

The power arrester is not delivered with the equipment. Please purchase it based on actual requirements.

Precautions during the installation:

- Make sure that the PE terminal of the power arrester is well grounded.
- After the AC power plug of the switch is connected to the socket of the power arrester, the lightning protection function is implemented only if the running status LED is green and the alarm LED is off.
- If the alarm LED on the power arrester is red, check whether it is caused by a poor grounding connection or by the reversed connection of the neutral and live wires. The detection method is as follows: Use a multimeter to measure the polarity of the power arrester when the alarm LED is red. If the neutral wire is on the left and the live wire is on the right (facing the socket), the PE terminal of the power arrester is not grounded. If not, the polarity of the power arrester should be reversed. In this case, open the power arrester and reverse its polarity. If the alarm LED is still red, the PE terminal of the power arrester is not grounded.

6.3.2 Installing the Ethernet Port Arrester

Please connect an Ethernet port arrester to the switch to prevent the damage by lightning strikes before connecting an outdoor Ethernet cable to the switch.

- Tools: Phillips screwdriver or flat-blade screwdriver, multimeter, and diagonal pliers
- Installation steps
 - a Tear one side of the protective paper for the double-sided adhesive tape and paste the tape to the enclosure of the Ethernet port arrester. Tear the other side of the protective paper for the double-sided adhesive tape and paste the Ethernet port arrester to the switch enclosure. The paste position for the Ethernet port arrester should be as close to the grounding lug of the switch as possible.
 - b Based on the distance between the grounding lug of the switch and the Ethernet port arrester, cut the grounding cable of the Ethernet port arrester and firmly tighten the grounding cable to the grounding lug of the switch.
 - c Use a multimeter to check whether the grounding cable for the arrester is in good contact with the grounding lug and the enclosure of the switch.
 - d Connect the Ethernet port arrester by using an adapter cable (note that the external Ethernet cable is connected to the IN end, while the adapter cable connected to the switch is connected to the OUT end) and check whether the module LED is normal.
 - e Use a nylon cable tie to bind the cables.

Figure 6-5 Installing an Ethernet Port Arrester

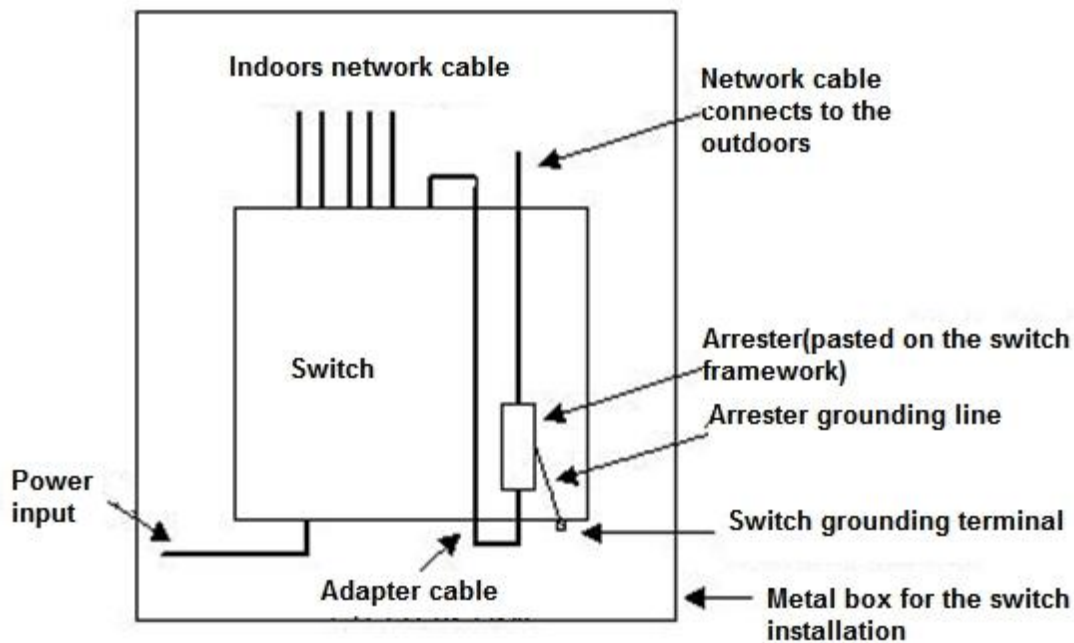

⚠ Caution

- The Ethernet port arrester is only for a 10 Mbps, 100 Mbps, or 1000 Mbps RJ45 port.

- The Ethernet port arrester is not delivered with the equipment. Please purchase it based on actual requirements. The user manual for Ethernet port arresters contains technical parameters and maintenance and installation instructions. Carefully read this manual during installation.
-

Pay attention to the following situations during the actual installation to avoid influencing the performance of an Ethernet port arrester:

- The arrester is incorrectly connected to the cables. Connect the external Ethernet cable to the IN end and connect the Ethernet port of the switch to the OUT end.
- The Ethernet port arrester is incorrectly grounded. The grounding cable of the arrester should be as short as possible to ensure that it is in good contact with the grounding lug of the switch. Use a multimeter to confirm the contact condition after grounding.
- Not all Ethernet ports are installed with Ethernet port arresters. If outdoor Ethernet cables connect the switch ports to the peer equipment, Ethernet port arresters need to be installed on all the ports for the purpose of lightning protection.

6.4 Recommended Cabling

When the switch is installed in a standard 19-inch cabinet, secure the cables around the cable management brackets. Top cabling or bottom cabling is adopted according to the actual situation in the equipment room. All adapted connectors should be placed at the bottom of the rack in an orderly manner instead of outside the rack that is easy to touch. Power cords are routed beside the rack. Top cabling or bottom cabling is adopted according to the actual situation in the equipment room, such as the positions of the DC power distribution box, AC socket, or lightning protection box.

6.4.1 Requirement for the Minimum Bend Radius of Cables

- The bend radius of a fixed power cord, Ethernet cable, and flat cable should be over five times greater than their respective external diameters. The bend radius of these cables that are often bent or plugged should be over seven times greater than their respective external diameters.
- The bend radius of a fixed common coaxial cable should be over seven times greater than its external diameter. The bend radius of these cables that are often bent or plugged should be over 10 times greater than their respective external diameters.
- The minimum bend radius of a high-speed cable, such as an SFP+ cable, should be 5 times the overall diameter of the cable. If the cable is constantly bent, plugged or unplugged, the bend radius should be 10 times the overall diameter.
- The minimum bend radius of optical cables should meet the following requirements.
 - The diameter of the optical cable tray should be no less than 25 times greater than that of the optical cable.
 - When an optical cable is moved, its bend radius should be no less than 20 times greater than its diameter.
 - During cabling of an optical cable, its bend radius should be no less than 10 times greater than its diameter.

6.4.2 Precautions for Cable Bundling

- Before cables are bundled, mark labels and stick the labels to cables wherever appropriate.

- Cables should be neatly and properly bundled in the rack without twisting or bending, as shown in [Figure 6-6](#).

Figure 6-6 Bundling Cables (1)

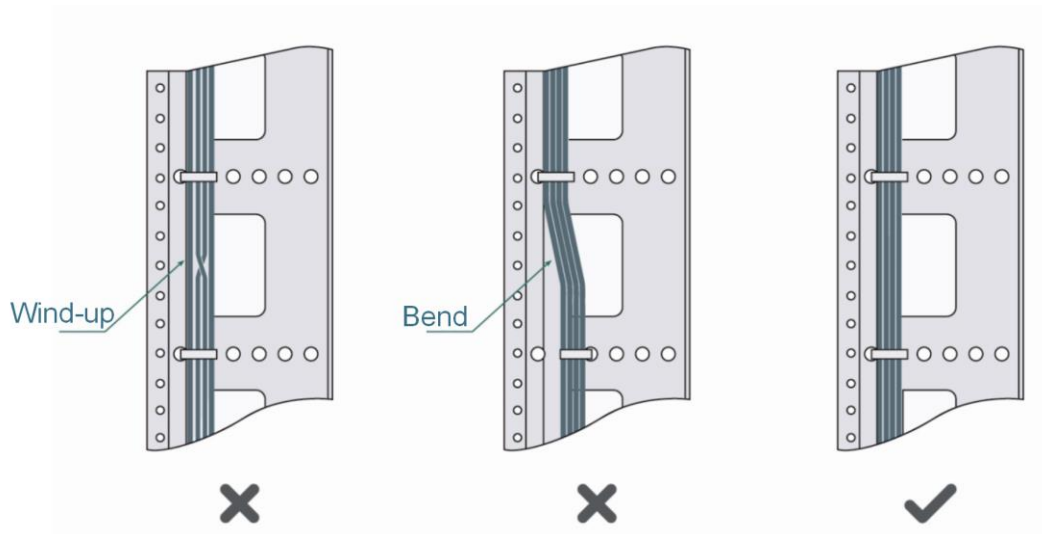

- Cables of different types (such as power cords, signal cables, and grounding wires) should be separated in cabling and bundling. Mixed bundling is not allowed. When they are close to each other, you are advised to adopt crossover cabling. In the case of parallel cabling, maintain a minimum distance of 30 mm (1.18 in.) between power cords and signal cables.
- The cable management brackets and cabling troughs inside and outside the rack should be smooth without sharp corners.
- The metal holes traversed by cables should have a smooth and fully rounded surface or an insulated lining.
- Use cable ties to bundle cables properly. Please do not connect two or more cable ties to bundle cables.
- After bundling up cables with cable ties, cut off the remaining part. The cut should be smooth and trim without sharp corners, as shown in [Figure 6-7](#).

Figure 6-7 Bundling Cables (2)

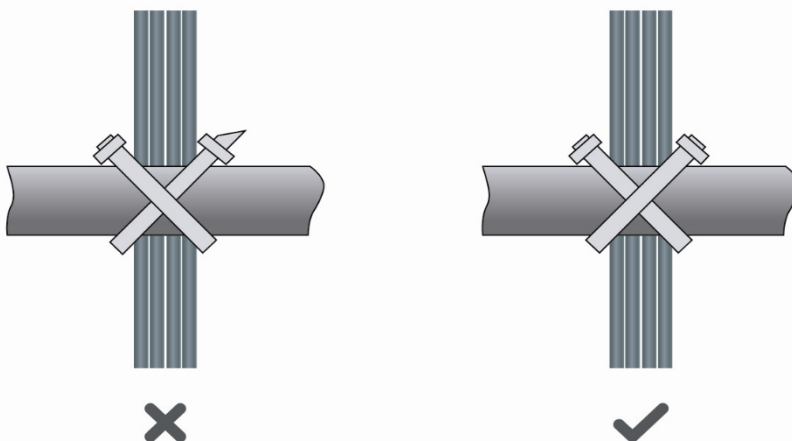

- When cables need to be bent, bundle them first but do not tie cables within the bend. Otherwise, stress may be generated on the cables and cause the wires inside to break, as shown in [Figure 6-8](#).

Figure 6-8 Bundling Cables (3)

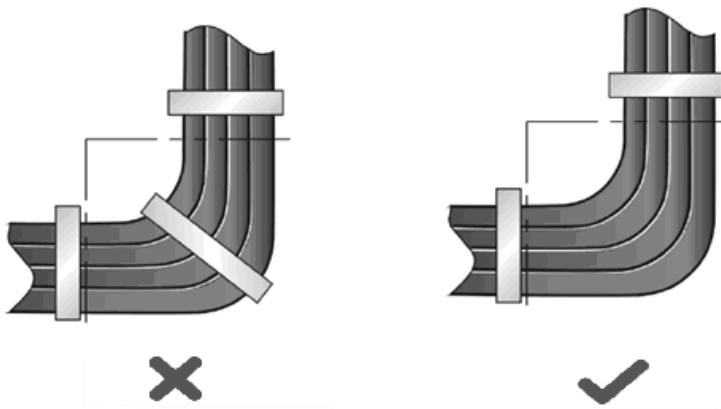

- Cables not to be assembled or the remaining parts of cables should be folded and placed in a proper position of the rack or cable management trough. The proper position refers to a position that does not affect the equipment running or damage the equipment or cables.
- Power cords must not be bundled on the guide rails of moving parts.
- The power cords connecting moving parts such as door grounding wires should be reserved with some excess after being assembled to avoid suffering tension or stress. When a moving part reaches the installation position, the remaining cable part should not touch heat sources, sharp corners, or sharp edges. If heat sources must be touched, high-temperature cables should be used.
- When using screw threads to secure a cable lug, ensure that the bolt or screw is properly tightened and take measures to prevent it from loosening, as shown in [Figure 6-9](#).

Figure 6-9 Fastening Cables

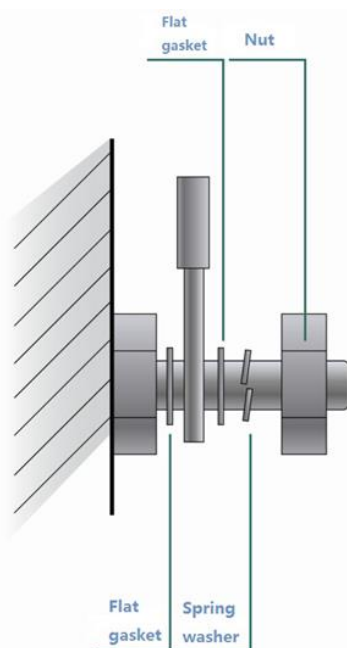

- Hard power cords should be secured near the cable termination area to prevent stress on the cable termination area and cables.
- Do not use tapping screws to secure cable lugs.
- Power cords of the same type and in the same cabling direction should be bundled up into cable bunches, with cables in cable bunches clean and straight.
- Bundle cables by using cable ties according to the following table.

Cable Bunch Diameter	Bundling Spacing
10 mm (0.39 in.)	80–150 mm (3.15–5.91 in.)
10–30 mm (0.39–1.18 in.)	150–200 mm (5.91–7.87 in.)
30 mm (1.18 in.)	200–300 mm (7.87–11.81 in.)

- Do not tie cables or bundles in a knot.
- For wiring terminal blocks (such as circuit breakers) with cord end terminals, the metal part of the cord end terminal should not be exposed outside the terminal block when assembled.

6.5 Site Selection

- The equipment room should be at least 5 km (3.11 miles) away from heavy pollution sources, such as smelters, coal mines, and thermal power plants. The equipment room should be at least 3.7 km (2.30 miles) away from medium pollution sources, such as the chemical factory, rubber factory, and electroplating factory. The equipment room should be at least 2 km (1.24 miles) away from light pollution sources, such as the food factory and leather plant. If the pollution source is unavoidable, the equipment room should be located on the windward side of the pollution source perennially with advanced protection.
- The equipment room should be at least 3.7 km (2.30 miles) away from the sea or salt lake. Otherwise, the equipment room must be sealed, with an air conditioner installed for temperature control. Saline soil cannot be used for construction. Otherwise, you should select equipment with advanced protection against severe environments.
- Do not build the equipment room in the proximity of livestock farms. Otherwise, the equipment room should be located on the windward side of the pollution source perennially. The previous livestock house or fertilizer warehouse cannot be used as the equipment room.
- The equipment room should be firm enough to withstand severe weather conditions such as windstorms, heavy rain, and dense dust. If the dust is unavoidable, keep the door and window away from the pollution source.
- The equipment falls into Class A. Therefore, the equipment room should be located away from the residential area. Otherwise, the equipment room should meet construction specifications to avoid noise and radio interference.
- Make sure the air vent of the equipment room is away from the sewage pipe, septic tank, and sewage treatment tank. Keep the equipment room under positive pressure to prevent corrosive gas from entering the equipment room to corrode components and circuit boards.

- Keep the equipment room away from industrial boilers and heating boilers.
- The equipment room should be on the second floor or higher. Otherwise, the equipment room floor should be 600 mm (23.62 in.) higher than the highest flood level ever recorded.
- Make sure no cracks or holes exist in the wall and floor. If there are cable entries in the wall or window, take proper sealing measures. Ensure that the wall is flat, wear-resistant, and dust-free, meeting standards for flame resistance, soundproofing, heat absorption, dust reduction, and electromagnetic shielding.
- Keep the door and the window closed to make the equipment room sealed.
- You are advised to use the steel door for soundproofing.
- Do not use sulfur-containing materials.
- Keep the air conditioner from blowing wind straight toward the equipment or blowing water drops from the window or air vent toward the equipment.

Contents

1 Overview	4
1.1 About the RG-ES207GS-P	4
1.2 Equipment Appearance	4
1.2.1 Front Panel.....	4
1.2.2 Rear Panel	5
1.2.3 LEDs	6
1.3 Cooling.....	7
1.4 Technical Specifications	7
2 Preparing for Installation	10
2.1 Package Contents.....	10
2.2 Safety Guidelines.....	10
2.2.1 General Precautions	10
2.2.2 Chassis-Lifting Guidelines	10
2.2.3 Electricity Safety	11
2.2.4 Preventing ESD Damage.....	12
2.2.5 Laser Safety	12
2.3 Site Requirements	12
2.3.1 Floor Loading	12
2.3.2 Airflow.....	13
2.3.3 Space	13
2.3.4 Temperature and Humidity.....	13
2.3.5 Cleanliness.....	13

2.3.6 Grounding	14
2.3.7 Preventing Electromagnetic Interference	14
2.3.8 Surge Protection	15
2.3.9 Installation Site.....	15
2.4 Tools	15
3 Installing the Switch	16
3.1 Before You Begin.....	16
3.2 Installing the Switch	16
3.2.1 Wall Mount	16
3.2.2 Workbench Mount.....	17
3.3 Grounding the Equipment.....	17
3.4 Connecting Cables.....	18
3.5 Bundling Cables.....	18
3.5.1 Precautions	18
3.5.2 Bundling Procedure	18
3.6 Verifying Installation.....	18
4 Commissioning.....	20
4.1 Power-on.....	20
4.2 Logging In to the Management Interface.....	20
5 Troubleshooting.....	21
5.1 General Troubleshooting Flowchart	21
5.2 Common Faults.....	21
6 Appendix.....	23
6.1 Connectors and Media.....	23

6.1.1 10Or100Or1000BASE-T Port	23
6.1.2 Optical Cable Connection	24
6.2 SFP Transceivers	25
6.3 Lightning Protection	28
6.3.1 Installing the AC Power Arrester (Power Strip with Surge Protection)	28
6.3.2 Installing the Ethernet Port Arrester	29
6.4 Recommended Cabling	31
6.4.1 Requirement for the Minimum Bend Radius of Cables	31
6.4.2 Precautions for Cable Bundling	31
6.5 Site Selection	35

1 Overview

1.1 About the RG-ES207GS-P

The RG-ES207GS-P Ethernet switch provides six 10/100/1000BASE-T ports, one 1GE SFP port, one Reset button, and several LEDs on the front panel, along with a 54 V DC power port, a DIP switch, and a grounding stud on the rear panel. Ports 1–4 support Power over Ethernet (PoE) Out.

Figure 1-1 RG-ES207GS-P Appearance

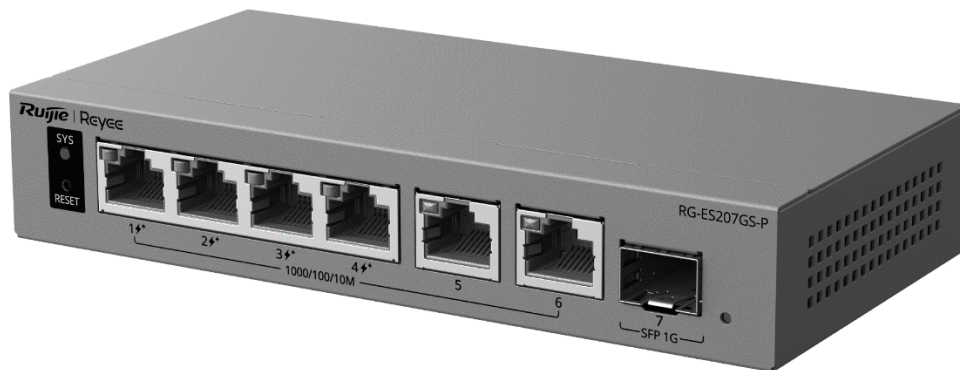

Note

- 1GE SFP port: Supports only 1GE SFP optical transceivers (not compatible with 100 Mbps optical cables).
 - 10/100/1000BASE-T port: Supports auto-negotiation at 10 Mbps, 100 Mbps, and 1000 Mbps.
-

1.2 Equipment Appearance

1.2.1 Front Panel

Figure 1-2 Front Panel of the RG-ES207GS-P

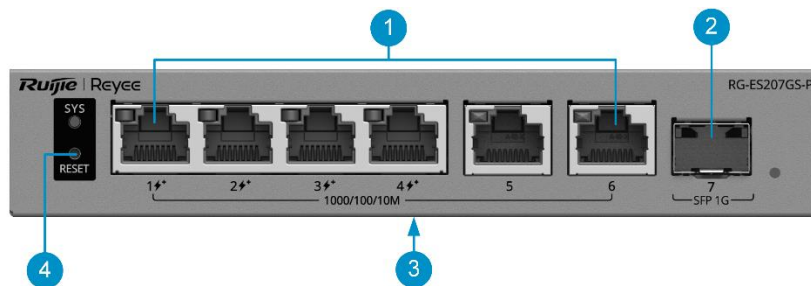

Note

 indicates the PoE+ ports, which are compliant with IEEE 802.3at, and backward compatible with IEEE 802.3af.

Table 1-1 Components on the Front Panel

No.	Component	Silkscreen	Description
1	RJ45 port	1–6	10/100/1000BASE-T ports, with ports 1–4 supporting PoE Out.
2	SFP port	7	1GE SFP port, supporting 1GE SFP transceiver (hot-swappable)
3	Nameplate	-	It is located at the bottom of the switch.
4	Reset button	RESET	<ul style="list-style-type: none"> Press and hold the button for less than 2 seconds. The switch is reset. Press and hold the button for 2–5 seconds. No action is performed. Press and hold the button for more than 5 seconds, and release the button until the system status LED starts blinking to restore factory settings and restart the switch.

Note

For details about LEDs on the front panel, see "LEDs."

1.2.2 Rear Panel

Figure 1-3 Rear Panel of the RG-ES207GS-P

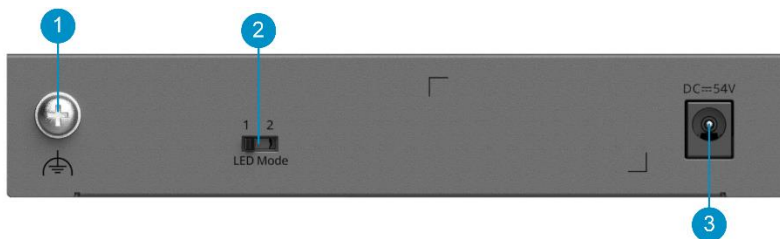

Table 1-2 Components on the Rear Panel

No.	Component	Description
1	Grounding stud	It is connected to a grounding wire.
2	DIP switch	<p>Toggle the DIP switch to change the LED modes of ports 1–4.</p> <ul style="list-style-type: none"> LED mode 1 (switching mode): When the DIP switch is toggled to the left, the port LEDs display the data transmission status. LED mode 2 (PoE mode): When the switch is toggled to the right, the port LEDs display the PoE status.

No.	Component	Description
3	DC power port	It is connected to a 54 V DC power source to supply power to the switch. The matching DC power connector has an outer diameter of 5.5 mm (0.22 in.), an inner diameter of 2.1 mm (0.08 in.), and a depth of 10 mm (0.39 in.).

1.2.3 LEDs

Figure 1-4 RG-ES207GS-P LEDs

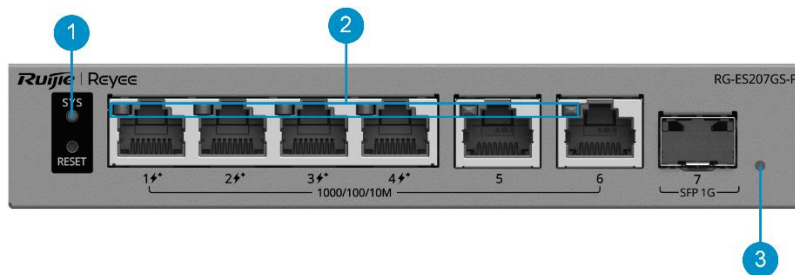

Table 1-3 LEDs

No.	Component	Silkscreen	Description
1	System status LED	SYS	<ul style="list-style-type: none"> ● Off: The switch is not powered on. ● Slow blinking green (0.5 Hz): The switch is operating normally but is not connected to Ruijie Cloud. ● Fast blinking green (10 Hz): The switch is upgrading or restarting, and is temporarily unavailable. ● Solid green: The switch is operating normally and connected to Ruijie Cloud. ● Slow blinking yellow (0.5 Hz): The PoE power is insufficient. ● Slow blinking red (0.5 Hz): A loop occurs on the switch with loop guard enabled.
2	RJ45 port LED	-	<p>LEDs of ports 1–4 support switching mode and PoE mode, which can be switched by toggling the DIP switch on the rear of the switch. LEDs of ports 5 and 6 support only switching mode.</p> <ul style="list-style-type: none"> ● Switching mode: <ul style="list-style-type: none"> ○ Off: The port is not connected. ○ Solid green: The port is operating at 1000 Mbps, 100 Mbps, or 10 Mbps, but is not receiving or sending data. ○ Blinking green: The port is operating at 1000 Mbps, 100 Mbps, or 10 Mbps, and is receiving or sending data. ● PoE mode: <ul style="list-style-type: none"> ○ Off: PoE is disabled on the port. ○ Solid green: PoE is enabled on the port. ○ Blinking green: PoE overload occurs on the port.
3	SFP port LED	-	<ul style="list-style-type: none"> ● Off: The port is not connected.

No.	Component	Silkscreen	Description
			<ul style="list-style-type: none"> ● Solid green: The port is operating at 1000 Mbps, but is not receiving or sending data. ● Blinking green: The port is operating at 1000 Mbps, and is receiving or sending data.

1.3 Cooling

The RG-ES207GS-P adopts fanless design and uses natural cooling. To ensure that the equipment works properly in the specified environment, a minimum clearance of 10 cm (3.94 in.) must be maintained around the equipment for air circulation and ventilation.

1.4 Technical Specifications

Warning

- This equipment is not suitable for use in locations where children are likely to be present.
- Operation of this equipment in a residential environment could cause radio interference.

Table 1-4 Technical Specifications

Parameter Type	Parameter Name	RG-ES207GS-P
System Specifications	Forwarding rate	10.41 Mpps
	Switching capacity	14 Gbps(bit/s)
	Flash memory	8 MB
Port Specifications	Total number of optical ports	1
	Total number of RJ45 ports	6
	Number of 10/100/1000BASE-T ports	6
	Number of 1GE SFP ports	1
	Reset button	1
	LEDs	1 x system status LED 6 x Ethernet port LEDs 1 x SFP port LED
	DIP switch	LED mode switch toggled to left (Mode 1): The port LED status indicates the status of traffic transmission. Solid green means that the port is

Parameter Type	Parameter Name	RG-ES207GS-P
		<p>link up, while blinking green means that the port is transmitting and receiving data.</p> <p>LED mode switch toggled to right (Mode 2): The port LED status indicates the PoE status. Solid green means that the port is supplying power, while blinking green means that the port is in power overload state.</p>
Power Supply and Consumption	Power supply	<ul style="list-style-type: none"> ● DC power adapter
	Power input	<p>DC adapter:</p> <ul style="list-style-type: none"> ● Rated input voltage: 100 V AC to 240 V AC, 50 Hz to 60 Hz ● Maximum input voltage: 90 V AC to 264 V AC, 47 Hz to 63 Hz ● Rated input current: 1.5 A <p>Output :</p> <ul style="list-style-type: none"> ● Rated output voltage: 54 V DC ● Maximum output current: 1.2 A
	Maximum power consumption	<p>4 W (with no PoE load)</p> <p>58 W (with full PoE load)</p>
	Number of PoE Out ports	4
	Number of PoE/PoE+ Out ports	4
	PoE Out standard	PoE/PoE+ (IEEE 802.3af/at)
	PoE power pins	1–2 (+), 3–6 (-)
	PoE budget per port	30 W
	PoE budget	54 W
Dimensions and Weight	Product dimensions (W x D x H)	<p>155mm x 78mm x 28mm</p> <p>(6.10 in. x 3.07 in. x 1.10 in.)</p>
	Weight	0.29 kg (0.64 lbs) (without packaging materials)
	Shipping weight	1.12 kg (2.47 lbs)
	Casing	Metal
Interface	EEE	Yes
	Mounting options	Wall/Desk

Parameter Type	Parameter Name	RG-ES207GS-P
Environment and Reliability	Hot swapping of cables	Hot swapping supported by the service port and power connector
	Fan	Fanless design
	Cooling	Natural cooling
	MTBF	200,000 hours
	ESD protection	Air discharge: 8 kV Contact discharge: 6 kV
	Surge protection	Service port: ± 6 kV for common mode Power connector: ± 4 kV for common mode and ± 2 kV for differential mode
	Operating temperature	0°C to +40°C (32°F to 104°F)
	Storage temperature	-40°C to +70°C (-40°F to +158°F)
	Operating humidity	10% RH to 90% RH (non-condensing)
	Storage humidity	5% RH to 95% RH (non-condensing)
	Altitude	-500 m to +5,000 m (-1,640.42 ft. to +16,404.20 ft.)
Certification and Regulatory Compliance	EMC	EN 55032 EN 61000-3-2 EN 61000-3-3 EN 55035 EN 300 386
	Safety compliance	EN 62368-1 IEC 62368-1
	Certification	CE,CB

2 Preparing for Installation

2.1 Package Contents

Table 2-1 Package Contents

No.	Item	Quantity
1	RG-ES207GS-P switch	1
2	User Manual	1
3	Warranty Card	1
4	Power adapter	1
5	Power cord	1

Note

The package contents are subject to the purchase contract, and actual delivery may vary. Please check the items carefully against the package contents or purchase contract. If you have any questions, please contact the distributor.

2.2 Safety Guidelines

Note

- To avoid personal injury or equipment damage, review the safety guidelines in this chapter before you begin the installation.
 - The following safety guidelines may not include all the potentially hazardous situations.
-

2.2.1 General Precautions

- Never operate the equipment in a wet environment, and avoid any liquids inside it. Keep the chassis clean and dust-free.
- Keep the equipment away from heat sources.
- Keep the equipment away from walk areas.
- During installation and maintenance, do not wear loose clothing or ornament that may get caught in the chassis.
- Keep tools and accessories away from walk areas.

2.2.2 Chassis-Lifting Guidelines

- Avoid moving the equipment frequently.
- Turn off all power supplies and disconnect all cables before lifting or moving the equipment.

2.2.3 Electricity Safety

Warning

- Any deviation from standard or improper electrical operations can result in accidents such as fires or electric shocks, potentially causing severe or even fatal harm to both individuals and equipment.
 - Direct or indirect touch through a wet object on high-voltage and mains supply can bring a fatal danger.
-

- Always observe the local regulations and standards. Only qualified personnel should be allowed to operate the equipment.
- Carefully check the work area for potential hazards, including ungrounded power system, absent safety grounds, and damp floors.
- Locate the emergency power-off switch in the room before installation. In the case of an accident, cut off the power supply immediately.
- Never assume that power is connected to or disconnected from a circuit. Always check.
- Select the right leakage protector (also called "leakage current switch" or "leakage current breaker") for the power supply system. This equipment automatically disconnects the power supply in the event of leakage and the risk of electric shock. A leakage protector should meet the following requirements:
 - The rated leakage action current of each leakage protector must be at least twice the total maximum leakage current of all connected power supplies.

Example:

If a system has 16 identical power supplies, each with a maximum leakage current of 3.5 mA:

Total leakage current = $16 \times 3.5 \text{ mA} = 56 \text{ mA}$

For a 30 mA leakage protector:

Maximum number of power supplies per protector = $30 \text{ mA} / 3.5 \text{ mA} \approx 4$

Therefore, only four power supplies can be connected to one 30 mA leakage protector.

To support 16 power supplies, at least four 30 mA leakage protectors are required.

Always ensure:

Rated leakage operating current/2 > Total maximum leakage current of connected power supplies

- The rated leakage non-action current of a leakage protector should be 50% of the leakage action current. If the non-action current value is too small, the high sensitivity level can cause the circuit to break, leading to power cutoff and service interruption, even if the leakage current value is normal.

For example, if a leakage protector has a rated leakage action current of 30 mA, the rated leakage non-action current should be 15 mA. The leakage protector will not activate unless the leakage current exceeds 15 mA.

Caution

- To ensure personal safety, each leakage protector in the system must have a rated leakage action current equal to or below 30 mA, which is the recognized safety threshold for human body current. If the total leakage current of the system exceeds twice the 30 mA limit, the system must be equipped with two or more leakage protectors to maintain safety.
 - The leakage current values vary with equipment. For the leakage current value of each equipment model, see "Technical Specifications."
-

2.2.4 Preventing ESD Damage

- Ensure that the chassis is connected to earth ground.
- Keep the site as dust free as possible.
- Maintain appropriate humidity conditions.
- Before installing any pluggable modules, wear an anti-ESD wrist strap and make sure that it is properly grounded.
- Avoid contact between the printed circuit boards and clothing. The anti-ESD wrist strap only protects the printed circuit boards from ESD voltages on the body. ESD voltages on clothing can still cause damage.

2.2.5 Laser Safety

The equipment supports various types of optical transceivers, which are Class 1 laser products.

Precautions:

- When an optical transceiver is working, ensure that its port is connected to an optical cable or covered by a dust cap to keep out dust and prevent it from burning your eyes.
- Do not stare into an optical port.

Figure 2-1 Laser Product ID

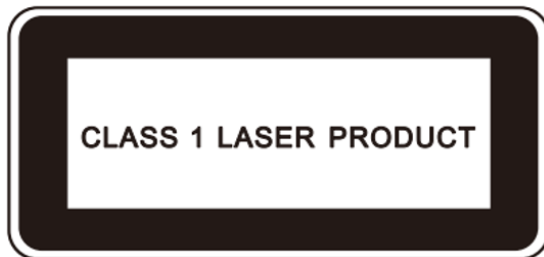

Caution

Do not approach or stare into an optical port under any circumstances. This may cause permanent damage to your eyes.

2.3 Site Requirements

The equipment must be installed indoors for normal operation and prolonged service life.

The installation site must meet the following requirements.

2.3.1 Floor Loading

Assess the combined weight of the equipment and its accessories, such as chassis and power modules, and verify that the floor under the rack can bear the weight.

2.3.2 Airflow

The equipment adopts natural cooling. Reserve a sufficient clearance around the equipment to ensure proper ventilation.

2.3.3 Space

Do not install the equipment against a wall. Instead, maintain a minimum clearance of 10 cm (3.94 in.) around the equipment for heat dissipation and equipment maintenance.

2.3.4 Temperature and Humidity

To ensure the normal operation and a prolonged service life of the equipment, maintain an appropriate temperature and humidity in the installation environment.

Prolonged exposure to inappropriate temperature and humidity conditions can cause damage to the equipment.

- In an environment with high relative humidity, insulating materials are prone to poor insulation or even electricity leakage.
- In an environment with low relative humidity, insulating gaskets may shrink, resulting in screw loosening.
- In a dry environment, static electricity is more likely to occur, posing a risk to the internal circuits of equipment.
- A high temperature can accelerate the aging process of insulation materials, greatly reducing the availability of the equipment and severely affecting its service life.

2.3.5 Cleanliness

Dust poses a significant hazard to the equipment. Dust on the enclosure causes electrostatic adhesion, leading to poor contact of the metallic joints. Electrostatic adhesion is more likely to occur in an indoor environment with relatively low humidity, not only affecting the service life of the equipment, but also causing communication faults. The following table lists the requirements for dust concentration and particle size in the equipment room.

Table 2-2 Requirements for Dust

Particle Diameter	Unit	Concentration
≥ 0.5 μm	Particles/m ³	≤ 3.5 × 10 ⁶
≥ 5 μm	Particles/m ³	≤ 3.5 × 10 ⁶

Apart from dust, there are also requirements on the salt, acid, and sulfide in the air of the equipment room. These harmful substances will accelerate metal corrosion and component aging. Therefore, the equipment room should be properly protected against harmful gases, such as sulfur dioxide, hydrogen sulfide, nitrogen dioxide, and chlorine gas. The following table lists the limits on harmful gases.

Table 2-3 Requirements for Gases

Gas	Average (mg/m ³)	Maximum (mg/m ³)
Sulfur dioxide (SO ₂)	0.3	1.0
Hydrogen sulfide (H ₂ S)	0.1	0.5

Gas	Average (mg/m ³)	Maximum (mg/m ³)
Nitrogen dioxide (NO ₂)	0.5	1.0
Chlorine gas (Cl ₂)	0.1	0.3

Note

Average refers to the average value of harmful gases measured in a week. **Maximum** refers to the upper limit of harmful gases measured in a week for up to 30 minutes every day.

2.3.6 Grounding

A proper grounding system is crucial for ensuring stable and reliable operation, as well as preventing lightning strikes and interference. Carefully check the grounding conditions at the installation site according to the grounding requirements, and complete grounding properly based on the site situation.

- Safety Grounding

Ensure that the power distribution system is securely grounded if the equipment uses the AC power supply. Otherwise, electric shocks may occur when the insulation resistance between the power module and the chassis decreases.

Caution

- The building should provide a protective ground connection to ensure that the equipment is connected to a protective ground.
 - Verify that the AC socket is reliably connected to the protective grounding system of the building. If not, a protective grounding wire should be used to connect the protective grounding lug of the AC socket to the protective grounding system of the building.
-

- Lightning Grounding

The lightning protection system is an independent system composed of a lightning rod, a downlead conductor, and a connector connected to the grounding system. The grounding system is typically used for power reference grounding and safety grounding. Lightning grounding is required only for facilities, and is not required for the equipment.

- EMC Grounding

Electromagnetic compatibility (EMC) grounding includes shielded grounding, filter grounding, noise and interference suppression, and level reference.

2.3.7 Preventing Electromagnetic Interference

- Take interference prevention measures for the power supply system.
- Keep the equipment away from the grounding system or lightning protection grounding system of the power facility.
- Keep the equipment far away from high-frequency current equipment such as high-power radio transmitting stations and radar launchers.
- Take electromagnetic shielding measures when necessary.

2.3.8 Surge Protection

Although the equipment can guard against lightning strikes, strong lightning strikes may still damage the equipment. Take the following surge protection measures:

- Ensure that the grounding wire is in good contact with the ground.
- Ensure that the neutral point of the AC power socket is in good contact with the ground.
- Install a power arrester in front of the power input end to enhance surge protection for the power supply.

2.3.9 Installation Site

Regardless of whether the equipment is installed on a wall or a workbench, ensure that the following conditions are met:

- Maintain a proper clearance around the equipment for heat dissipation.
- Alternatively, place the equipment on a clean workbench. The installation of air conditioners is recommended in hot areas.

2.4 Tools

Table 2-4 Tools

Common Tools	Phillips screwdriver, cables, cage nuts, diagonal pliers, cable ties, and grounding wires
Dedicated Tools	Anti-ESD gloves, wire stripper, crimping pliers, RJ45 crimping pliers, and wire cutter
Meter	Multimeter

 **Note**

The equipment is delivered without a toolkit. Prepare the preceding tools by yourself.

3 Installing the Switch

⚠ Caution

Before installing the equipment, ensure that guidelines and requirements in Chapter 2 have been met.

3.1 Before You Begin

- The installation site provides sufficient space for heat dissipation.
- The installation site meets the temperature and humidity requirements.
- The power supply is available at the installation site, and its current meets the requirements.
- The Ethernet cables have been deployed at the installation site.
- Locate the emergency power-off switch in the room before installation. In the case of an accident, cut off the power supply immediately.

3.2 Installing the Switch

3.2.1 Wall Mount

i Note

- You need to prepare two M3 screws and two plastic expansion anchors for wall mounting.
 - For wall mounting, install the equipment only on concrete or other non-flammable surfaces.
-

The steps for wall mounting a switch are as follows:

- (1) Drill two holes at suitable positions on the wall with a spacing of 112.6 mm (4.43 in.). The hole diameter and depth depend on the specifications of the purchased plastic expansion anchors.
- (2) Insert two plastic expansion anchors into the drilled holes, and then screw two M3 screws into the plastic expansion anchors.

i Note

- Ensure that the distance between the inner side of the screw heads and the outer edge of the plastic expansion anchors is at least 2.5 mm (0.1 in.) to securely mount the equipment onto the screws.
 - The equipment appearance shown in the installation diagram is for reference only.
-

- (3) Mount the equipment on the two M3 screws, as shown in the following figure.

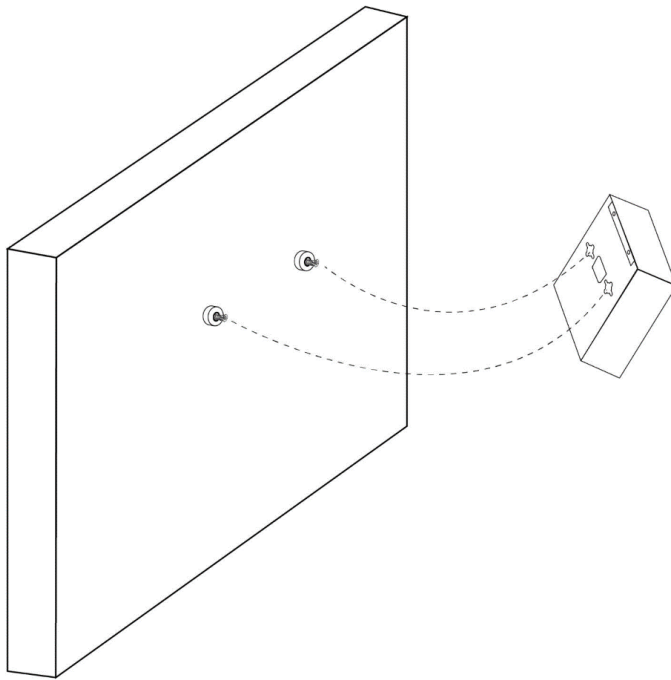
Figure 3-1 Mounting the Switch on a Wall

3.2.2 Workbench Mount

If wall mounting is not feasible, place the switch on a clean workbench and choose a location where it is unlikely to be touched, to ensure the safety and stability of the switch.

3.3 Grounding the Equipment

Note

- If the equipment is installed on a workbench, connect the grounding wire to the nearest grounding bar or grounding point based on the onsite situation.
 - The grounding wire is not delivered with the equipment and needs to be purchased by the customer.
-

The equipment has a grounding stud on the rear panel. You are advised to connect the system grounding wire to it before using the equipment.

- (1) Purchase a grounding wire and connect one end to the grounding stud at the rear of the equipment.
 - (2) Connect the other end of the grounding wire to the nearest grounding bar or grounding point.
-

Caution

- To avoid personal injury and equipment damage, connect the switch to earth ground properly. The grounding resistance between the chassis and the ground should be less than 1 ohm.
 - The O&M personnel should verify whether the AC socket is reliably connected to the protective ground of the building. If not, the O&M personnel should use a protective grounding wire to connect the protective grounding lug of the AC socket to the protective ground of the building.
 - The power socket should be installed near the equipment and easily accessible.
 - During the equipment installation, connect the grounding wire first and disconnect it last.
-

- The sectional area of a grounding wire should be determined according to the possible maximum current. Grounding wires with good conductors should be used.
 - Do not use bare wires.
-

3.4 Connecting Cables

Caution

- All cables must be routed indoors. Take surge protection measures if they need to be routed outdoors.
 - When connecting an optical cable, connect the transmit (TX) port on the local equipment to the receive (RX) port on the peer equipment, and vice versa.
-

After the switch is installed, connect the switch to other equipment according to the following steps:

- (1) Connect the power cord delivered with the switch to the power strip.
- (2) Connect the RJ45 connector of a twisted pair to an Ethernet port on the switch, and the other end to downlink equipment.
- (3) Insert an optical transceiver into the optical port first according to the panel identification. Then connect a single-mode fiber (SMF) or multimode fiber (MMF) to the corresponding optical transceiver, during which the transmitting and receiving ends of the optical cable should be distinguished.

3.5 Bundling Cables

3.5.1 Precautions

- Bundle the power cord and other cables in an esthetically pleasing way.
- Make sure that the optical cables at the connectors have natural bends or bends of large radius.
- Do not bind optical cables and twisted pairs too tightly, as this may press the cables and affect their service life and transmission performance.

3.5.2 Bundling Procedure

- (1) Bind the drooping part of the optical cables and twisted pairs, and lead them to both sides of the chassis for convenience.
- (2) Bind the power cord closely along the bottom of the chassis, in a straight line wherever possible.

3.6 Verifying Installation

Caution

Please turn off the power to avoid personal injury and damage to components caused by incorrect connection.

- Verify that the grounding wire is connected.
- Verify that the cables including power cords are properly connected.
- Verify that cables connected to ports are routed indoors.

- Verify that the surge protection socket and Ethernet port arrester are installed, if outdoor cabling exists.
- Verify that there is a minimum clearance of 10 cm (3.94 in.) around the switch.

4 Commissioning

4.1 Power-on

- (1) Checklist Before Power-on
 - The switch is properly grounded.
 - The power cord is properly connected.
 - The power supply voltage meets the requirement of the switch.
- (2) Checklist After Power-on (Recommended)
 - The switch LEDs are in the normal state.
 - Service ports can forward data properly.

4.2 Logging In to the Management Interface

- (1) Connect a PC to an Ethernet port on the switch through an Ethernet cable.
- (2) Set the IP address of the PC to 10.44.77.XXX (Range: 1–254, excluding 200).

Figure 4-1 Changing the IP Address

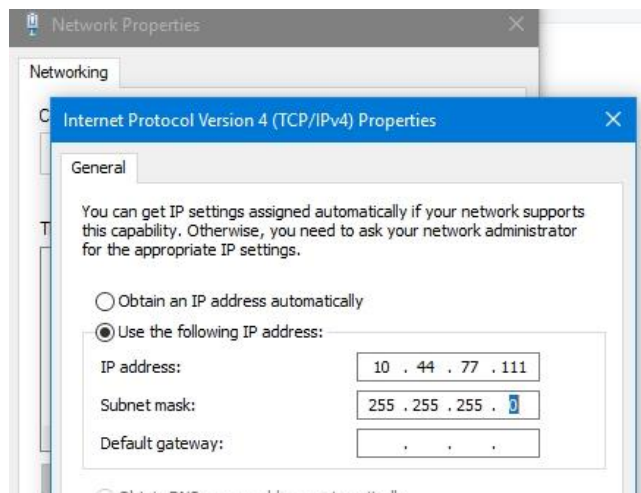

- (3) Open a browser, enter 10.44.77.200 in the address bar, and press Enter. On the login page, set a password and log in.
- (4) Perform equipment commissioning and configuration based on service requirements.

Note

For security purposes, you are advised to change the password regularly.

5 Troubleshooting

5.1 General Troubleshooting Flowchart

Note

You can determine whether each checking item in the process is normal based on the information provided in the previous chapters "Overview" and "Installing the Switch."

Figure 5-1 General Troubleshooting Flowchart

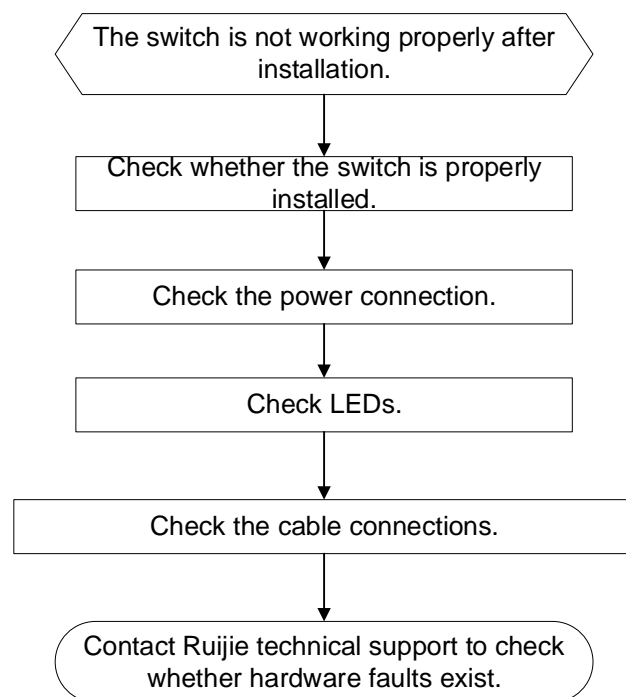

5.2 Common Faults

Table 5-1 Common Faults and Troubleshooting

Symptom	Possible Cause	Suggested Action
The system status LED is off after the switch is powered on.	No power is supplied to the switch or the power cord is loosely connected.	Check whether the power socket in the equipment room is normal and whether the power cord is loosely connected to the switch.
An RJ45 port is disconnected or a frame	The twisted pair is not connected properly.	Replace the twisted pair.

Symptom	Possible Cause	Suggested Action
sending/receiving error occurs.	The cable length exceeds 100 m (328.08 ft.).	Use an optical cable for data transmission or connect to an intermediate switch for relay.
	The port is specially configured and does not work in the same mode as that of the interconnected switch.	Check whether the port is configured to work in the same mode as that of the interconnected switch.
An optical port is not reachable.	The transmit and receive ends are connected incorrectly.	Exchange the transmit and receive ends of the optical cable.
	The types of the interconnected optical transceivers do not match.	Replace with one compatible optical transceiver.
	The optical cable type does not meet the requirements.	Replace the optical cable with a qualified one.
	The optical cable length is beyond the allowed length marked on the optical transceiver.	Use an optical cable with the required length.
	The optical cable or connector is contaminated.	Clean the connector with a lint-free cloth or a cleaning pen.
The login password cannot be retrieved.	The password is forgotten, and the equipment is not connected to the network or Ruijie Cloud.	Press and hold the Reset button to restore to factory settings.
	If the equipment is connected to Ruijie Cloud or a network, its login password is updated to the project or global management password.	If the equipment is connected to the cloud, log in using the project management password. If the equipment is connected to a network, log in using the global management password.
The Ethernet ports are transmitting and receiving frames normally, but their LEDs are off.	<p>The status of the Ethernet port LEDs is incorrectly displayed.</p> <p>The DIP switch is set to LED mode 2. As a result, the Ethernet port LEDs display the PoE status, but PoE is disabled on the ports.</p>	Set the DIP switch to LED mode 1 so that the Ethernet port LEDs display the data receiving and sending status.

6 Appendix

6.1 Connectors and Media

6.1.1 100r100Or1000BASE-T Port

The 10/100/1000BASE-T port supports auto-negotiation for 10 Mbps, 100 Mbps, and 1000 Mbps connections and also supports auto MDI/MDIX Crossover.

Compliant with IEEE 802.3ab, a 1000BASE-T port connects to a 100-ohm Category 5 (CAT5) or Category 5 Enhanced (CAT5e) Unshielded Twisted Pair (UTP), or recommended Shielded Twisted Pair (STP) cable with a maximum distance of 100 m (328.08 ft.).

The 1000BASE-T port requires that all four pairs of wires be connected for data transmission. [Figure 6-1](#) shows twisted pair connections for the 1000BASE-T port.

Figure 6-1 Twisted Pair Connections for a 1000BASE-T Port

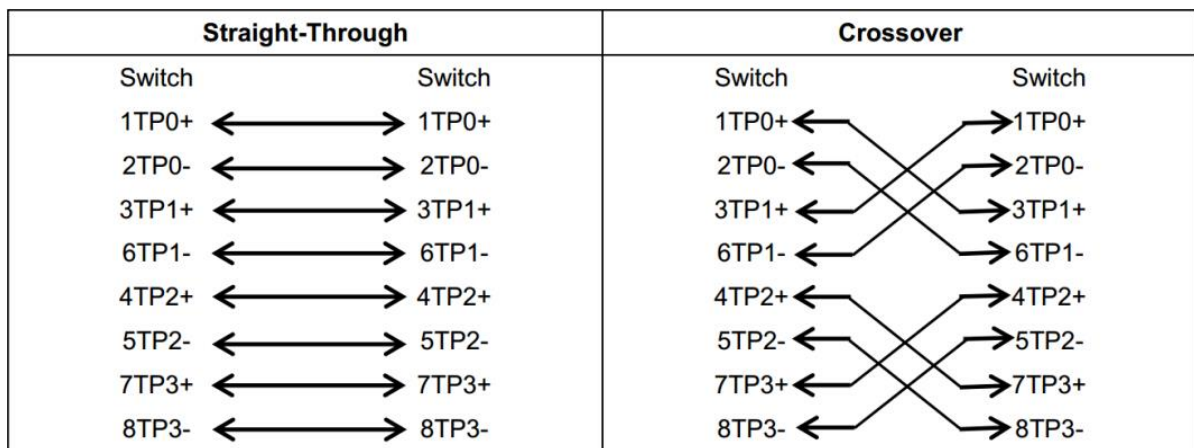

In addition to cables with the above-mentioned specifications, the 10/100BASE-T port can also be connected using 100-ohm CAT3, CAT4, and CAT5 cables at 10 Mbps or using 100-ohm CAT5 cables with a maximum distance of 100 m (328.08 ft.). The following table shows pin assignments for a 10/100BASE-T port.

Table 6-1 10/100BASE-T Pin Assignment

Pin	Socket	Plug
1	Input Receive Data+	Output Transmit Data+
2	Input Receive Data-	Output Transmit Data-
3	Output Transmit Data+	Input Receive Data+
6	Output Transmit Data-	Input Receive Data-
4, 5, 7, and 8	Not Used	Not Used

The following table shows wiring of straight-through and crossover cables for a 10/100BASE-T port.

Figure 6-2 Twisted Pair Connections for a 10/100BASE-T Port

Straight-Through		Crossover	
Switch	Adapter	Switch	Switch
1 IRD+	1 OTD+	1 IRD+ ←	1 OTD+ →
2 IRD-	2 OTD-	2 IRD- ←	2 OTD- →
3 OTD+	3 IRD+	3 OTD+ ←	3 IRD+ →
6 OTD-	6 IRD-	6 OTD- ←	6 IRD+ →

6.1.2 Optical Cable Connection

Select a single-mode fiber (SMF) or multimode fiber (MMF) for connections based on the type of the optical transceiver inserted into an optical port. [Figure 6-3](#) shows the connections.

Figure 6-3 Connecting the Optical Cables

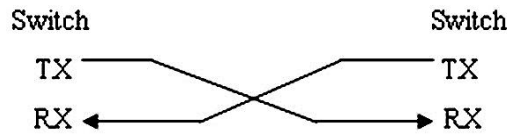

6.2 SFP Transceivers

Ruijie provides SFP transceivers (mini-GBIC) based on the port types. You can select one that suits your specific needs. In addition to the following 1GE SFP transceivers, the 1GE copper transceiver Mini-GBIC-GT is also supported. This document provides models and technical specifications of some 1GE SFP transceivers for reference. For details about the technical specifications, see *Ruijie Transceiver Installation and Reference Guide*.

Table 6-2 1GE Mini-GBIC (SFP) Models and Technical Specifications

Model	Wavelength (nm)	Fiber Type	DDM Supported (Yes/No)	Transmit Power (dBm)		Receive Power (dBm)	
				Min	Max	Min	Max
MINI-GBIC-SX-MM850	850	MMF	Yes	-9	-3	-20	-3
MINI-GBIC-LX-SM1310	1310	SMF	Yes	-9	-3	-26	0
GE-SFP-LH40-SM1310-BIDI	1310TX/1550RX	SMF	Yes	-3	3	-25	0
GE-SFP-LH40-SM1550-BIDI	1550TX/1310RX	SMF	Yes	-3	3	-25	0
GE-SFP-LX20-SM1310-BIDI	1310TX/1550RX	SMF	Yes	-8	-3	-23	-3
GE-SFP-LX20-SM1550-BIDI	1550TX/1310RX	SMF	Yes	-8	-3	-23	-3
MINI-GBIC-LH40-SM1310	1310	SMF	Yes	-5	0	-25	-3
MINI-GBIC-ZX80-SM1550	1550	SMF	Yes	-3	3	-26	-3
GE-SFP-LX03-SM1310-BIDI-I	1310TX/1550RX	SMF	Yes	-9	-3	-22	-3
GE-SFP-LX03-SM1550-BIDI-I	1550TX/1310RX	SMF	Yes	-9	-3	-22	-3
SFP-MM850	850	MMF	Yes	-9.5	-3	-17	-3
SFP-SM1310	1310	SMF	Yes	-9	-3	-20	-3

Table 6-3 1GE SFP Copper Transceivers

Standard	1000BASE-T SFP Module	DDM Supported (Yes/No)
1000BASE-T	Mini-GBIC-GT	No

Table 6-4 Cabling Specifications of SFP Transceivers

SFP Transceiver Model	Port Type	Fiber Type	Core Size (µm)	Max Cabling Distance
SFP-SM1310	LC	SMF	9/125	10 km (6.21 miles)
MINI-GBIC-LX-SM1310	LC	SMF	9/125	10 km (6.21 miles)
GE-SFP-LH40-SM1310-BIDI	LC	SMF	9/125	40 km (24.85 miles)
GE-SFP-LH40-SM1550-BIDI	LC	SMF	9/125	40 km (24.85 miles)
GE-SFP-LX20-SM1310-BIDI	LC	SMF	9/125	20 km (12.43 miles)
GE-SFP-LX20-SM1550-BIDI	LC	SMF	9/125	20 km (12.43 miles)
MINI-GBIC-LH40-SM1310	LC	SMF	9/125	40 km (24.85 miles)
MINI-GBIC-ZX80-SM1550	LC	SMF	9/125	80 km (49.71 miles)
GE-SFP-LX03-SM1310-BIDI-I	LC	SMF	9/125	3 km (1.86 miles)
GE-SFP-LX03-SM1550-BIDI-I	LC	SMF	9/125	3 km (1.86 miles)
MINI-GBIC-SX-MM850	LC	MMF	62.5/125	275 m (902.23 ft.)
			50/125	550 m (1,804.46 ft.)
SFP-MM850	LC	MMF	62.5/125	275 m (902.23 ft.)
			50/125	550 m (1,804.46 ft.)
Mini-GBIC-GT	RJ45 Ethernet cable	CAT5 or better UTP or STP cable		100 m (328.08 ft.)

 **Caution**

- For optical transceivers with a cabling distance of no less than 40 km (24.85 miles), install an optical attenuator to avoid overload on an optical receiver when using short-distance SMFs.
- An optical transceiver is a laser transmitter. Do not look into the light source to prevent it from burning your eyes.
- To keep the optical transceiver clean, make sure that the unused ports remain capped.

Table 6-5 BIDI Optical Transceiver Pairing

Rate/Distance	Pairing Model
1000 Mbps/3 km (1.86 miles)	GE-SFP-LX03-SM1310-BIDI-I GE-SFP-LX03-SM1550-BIDI-I
1000 Mbps/20 km (12.43 miles)	GE-SFP-LX20-SM1310-BIDI GE-SFP-LX20-SM1550-BIDI
1000 Mbps/40 km (24.85 miles)	GE-SFP-LH40-SM1310-BIDI GE-SFP-LH40-SM1550-BIDI

 **Caution**

BIDI optical transceivers must be used in pairs. For example, if GE-SFP-LX20-SM1310-BIDI is used at one end, GE-SFP-LX20-SM1550-BIDI must be used at the other end.

6.3 Lightning Protection

6.3.1 Installing the AC Power Arrester (Power Strip with Surge Protection)

When an alternating current (AC) power cord is introduced from outdoors and directly connected to the AC power port of the switch, the power port must be connected to an external power arrester to safeguard the switch against lightning strikes. The power arrester can be fixed on the rack, workbench, or wall in the equipment room by using cable ties and screws. AC power enters the power arrester before entering the switch.

Figure 6-4 Power Arrester

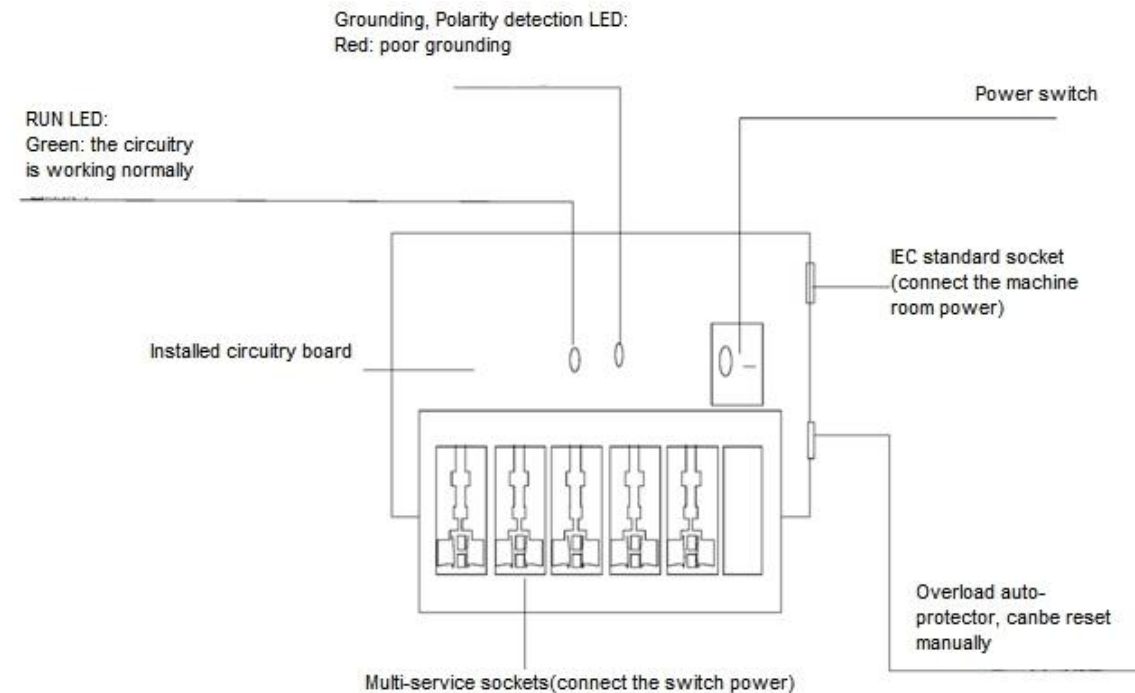

⚠ Caution

The power arrester is not delivered with the equipment. Please purchase it based on actual requirements.

Precautions during the installation:

- Make sure that the PE terminal of the power arrester is well grounded.
- After the AC power plug of the switch is connected to the socket of the power arrester, the lightning protection function is implemented only if the running status LED is green and the alarm LED is off.
- If the alarm LED on the power arrester is red, check whether it is caused by a poor grounding connection or by the reversed connection of the neutral and live wires. The detection method is as follows: Use a multimeter to measure the polarity of the power arrester when the alarm LED is red. If the neutral wire is on the left and the live wire is on the right (facing the socket), the PE terminal of the power arrester is not grounded. If not, the polarity of the power arrester should be reversed. In this case, open the power arrester and reverse its polarity. If the alarm LED is still red, the PE terminal of the power arrester is not grounded.

6.3.2 Installing the Ethernet Port Arrester

Please connect an Ethernet port arrester to the switch to prevent the damage by lightning strikes before connecting an outdoor Ethernet cable to the switch.

- Tools: Phillips screwdriver or flat-blade screwdriver, multimeter, and diagonal pliers
- Installation steps
 - a Tear one side of the protective paper for the double-sided adhesive tape and paste the tape to the enclosure of the Ethernet port arrester. Tear the other side of the protective paper for the double-sided adhesive tape and paste the Ethernet port arrester to the switch enclosure. The paste position for the Ethernet port arrester should be as close to the grounding lug of the switch as possible.
 - b Based on the distance between the grounding lug of the switch and the Ethernet port arrester, cut the grounding cable of the Ethernet port arrester and firmly tighten the grounding cable to the grounding lug of the switch.
 - c Use a multimeter to check whether the grounding cable for the arrester is in good contact with the grounding lug and the enclosure of the switch.
 - d Connect the Ethernet port arrester by using an adapter cable (note that the external Ethernet cable is connected to the IN end, while the adapter cable connected to the switch is connected to the OUT end) and check whether the module LED is normal.
 - e Use a nylon cable tie to bind the cables.

Figure 6-5 Installing an Ethernet Port Arrester

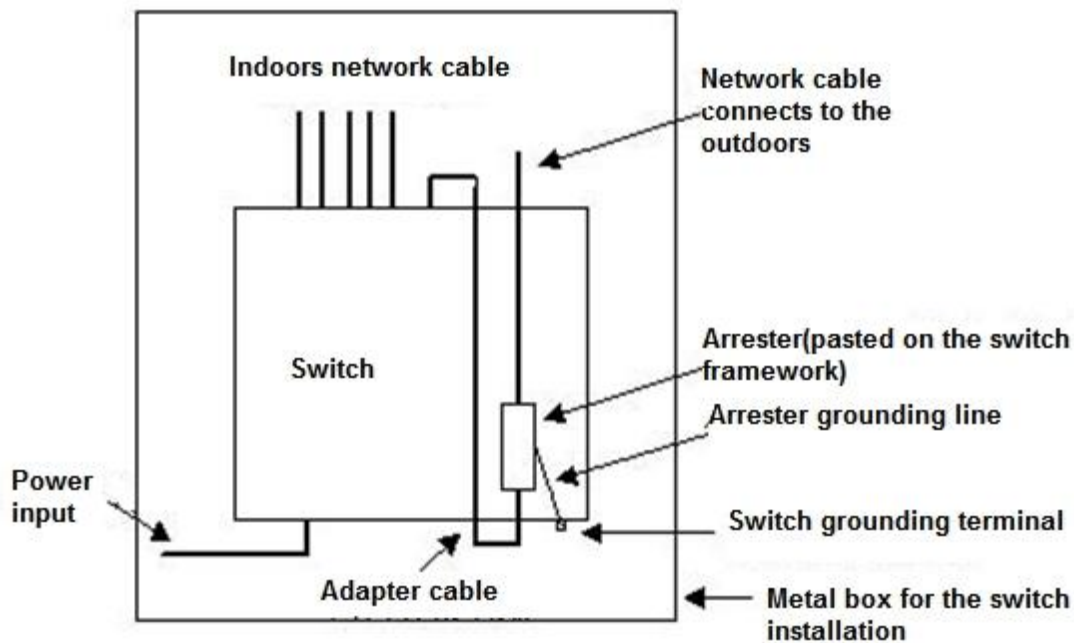

⚠ Caution

- The Ethernet port arrester is only for a 10 Mbps, 100 Mbps, or 1000 Mbps RJ45 port.

- The Ethernet port arrester is not delivered with the equipment. Please purchase it based on actual requirements. The user manual for Ethernet port arresters contains technical parameters and maintenance and installation instructions. Carefully read this manual during installation.
-

Pay attention to the following situations during the actual installation to avoid influencing the performance of an Ethernet port arrester:

- The arrester is incorrectly connected to the cables. Connect the external Ethernet cable to the IN end and connect the Ethernet port of the switch to the OUT end.
- The Ethernet port arrester is incorrectly grounded. The grounding cable of the arrester should be as short as possible to ensure that it is in good contact with the grounding lug of the switch. Use a multimeter to confirm the contact condition after grounding.
- Not all Ethernet ports are installed with Ethernet port arresters. If outdoor Ethernet cables connect the switch ports to the peer equipment, Ethernet port arresters need to be installed on all the ports for the purpose of lightning protection.

6.4 Recommended Cabling

When the switch is installed in a standard 19-inch cabinet, secure the cables around the cable management brackets. Top cabling or bottom cabling is adopted according to the actual situation in the equipment room. All adapted connectors should be placed at the bottom of the rack in an orderly manner instead of outside the rack that is easy to touch. Power cords are routed beside the rack. Top cabling or bottom cabling is adopted according to the actual situation in the equipment room, such as the positions of the DC power distribution box, AC socket, or lightning protection box.

6.4.1 Requirement for the Minimum Bend Radius of Cables

- The bend radius of a fixed power cord, Ethernet cable, and flat cable should be over five times greater than their respective external diameters. The bend radius of these cables that are often bent or plugged should be over seven times greater than their respective external diameters.
- The bend radius of a fixed common coaxial cable should be over seven times greater than its external diameter. The bend radius of these cables that are often bent or plugged should be over 10 times greater than their respective external diameters.
- The minimum bend radius of a high-speed cable, such as an SFP+ cable, should be 5 times the overall diameter of the cable. If the cable is constantly bent, plugged or unplugged, the bend radius should be 10 times the overall diameter.
- The minimum bend radius of optical cables should meet the following requirements.
 - The diameter of the optical cable tray should be no less than 25 times greater than that of the optical cable.
 - When an optical cable is moved, its bend radius should be no less than 20 times greater than its diameter.
 - During cabling of an optical cable, its bend radius should be no less than 10 times greater than its diameter.

6.4.2 Precautions for Cable Bundling

- Before cables are bundled, mark labels and stick the labels to cables wherever appropriate.
- Cables should be neatly and properly bundled in the rack without twisting or bending, as shown in [Figure 6-6](#).

Figure 6-6 Bundling Cables (1)

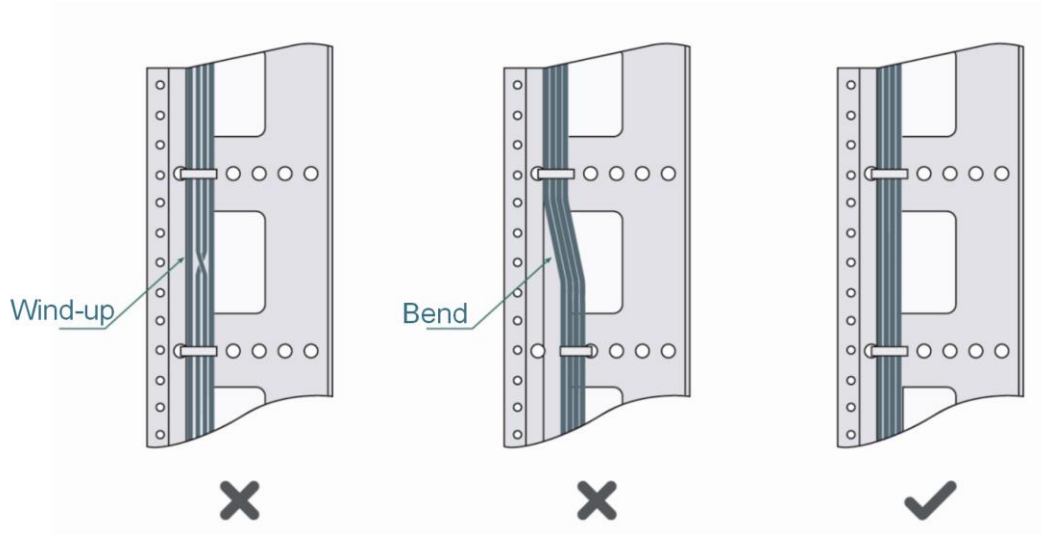

- Cables of different types (such as power cords, signal cables, and grounding wires) should be separated in cabling and bundling. Mixed bundling is not allowed. When they are close to each other, you are advised to adopt crossover cabling. In the case of parallel cabling, maintain a minimum distance of 30 mm (1.18 in.) between power cords and signal cables.
- The cable management brackets and cabling troughs inside and outside the rack should be smooth without sharp corners.
- The metal holes traversed by cables should have a smooth and fully rounded surface or an insulated lining.
- Use cable ties to bundle cables properly. Please do not connect two or more cable ties to bundle cables.
- After bundling up cables with cable ties, cut off the remaining part. The cut should be smooth and trim without sharp corners, as shown in [Figure 6-7](#).

Figure 6-7 Bundling Cables (2)

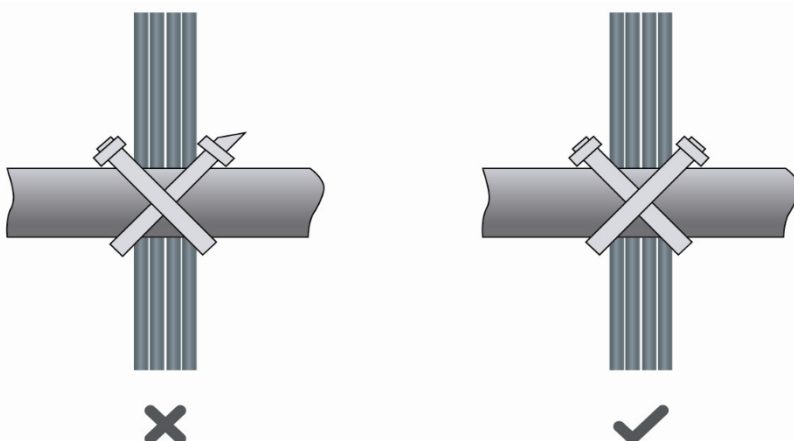

- When cables need to be bent, bundle them first but do not tie cables within the bend. Otherwise, stress may be generated on the cables and cause the wires inside to break, as shown in [Figure 6-8](#).

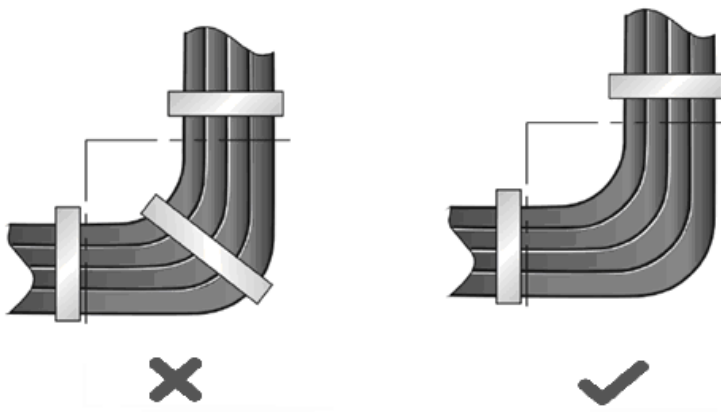
Figure 6-8 Bundling Cables (3)

- Cables not to be assembled or the remaining parts of cables should be folded and placed in a proper position of the rack or cable management trough. The proper position refers to a position that does not affect the equipment running or damage the equipment or cables.
- Power cords must not be bundled on the guide rails of moving parts.
- The power cords connecting moving parts such as door grounding wires should be reserved with some excess after being assembled to avoid suffering tension or stress. When a moving part reaches the installation position, the remaining cable part should not touch heat sources, sharp corners, or sharp edges. If heat sources must be touched, high-temperature cables should be used.
- When using screw threads to secure a cable lug, ensure that the bolt or screw is properly tightened and take measures to prevent it from loosening, as shown in [Figure 6-9](#).

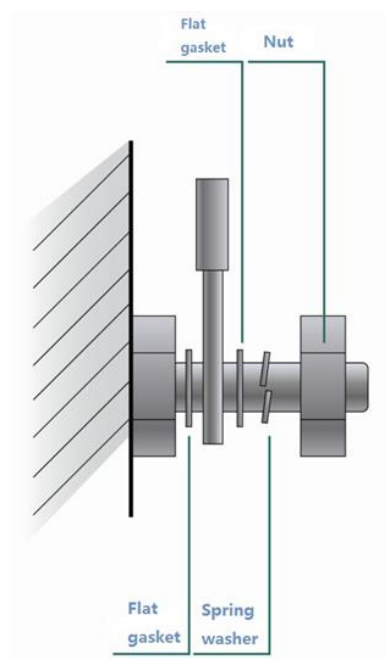
Figure 6-9 Fastening Cables

- Hard power cords should be secured near the cable termination area to prevent stress on the cable

termination area and cables.

- Do not use tapping screws to secure cable lugs.
- Power cords of the same type and in the same cabling direction should be bundled up into cable bunches, with cables in cable bunches clean and straight.
- Bundle cables by using cable ties according to the following table.

Cable Bunch Diameter	Bundling Spacing
10 mm (0.39 in.)	80–150 mm (3.15–5.91 in.)
10–30 mm (0.39–1.18 in.)	150–200 mm (5.91–7.87 in.)
30 mm (1.18 in.)	200–300 mm (7.87–11.81 in.)

- Do not tie cables or bundles in a knot.
- For wiring terminal blocks (such as circuit breakers) with cord end terminals, the metal part of the cord end terminal should not be exposed outside the terminal block when assembled.

6.5 Site Selection

- The equipment room should be at least 5 km (3.11 miles) away from heavy pollution sources, such as smelters, coal mines, and thermal power plants. The equipment room should be at least 3.7 km (2.30 miles) away from medium pollution sources, such as the chemical factory, rubber factory, and electroplating factory. The equipment room should be at least 2 km (1.24 miles) away from light pollution sources, such as the food factory and leather plant. If the pollution source is unavoidable, the equipment room should be located on the windward side of the pollution source perennially with advanced protection.
- The equipment room should be at least 3.7 km (2.30 miles) away from the sea or salt lake. Otherwise, the equipment room must be sealed, with an air conditioner installed for temperature control. Saline soil cannot be used for construction. Otherwise, you should select equipment with advanced protection against severe environments.
- Do not build the equipment room in the proximity of livestock farms. Otherwise, the equipment room should be located on the windward side of the pollution source perennially. The previous livestock house or fertilizer warehouse cannot be used as the equipment room.
- The equipment room should be firm enough to withstand severe weather conditions such as windstorms, heavy rain, and dense dust. If the dust is unavoidable, keep the door and window away from the pollution source.
- The equipment falls into Class A. Therefore, the equipment room should be located away from the residential area. Otherwise, the equipment room should meet construction specifications to avoid noise and radio interference.
- Make sure the air vent of the equipment room is away from the sewage pipe, septic tank, and sewage treatment tank. Keep the equipment room under positive pressure to prevent corrosive gas from entering the equipment room to corrode components and circuit boards.
- Keep the equipment room away from industrial boilers and heating boilers.
- The equipment room should be on the second floor or higher. Otherwise, the equipment room floor should be 600 mm (23.62 in.) higher than the highest flood level ever recorded.
- Make sure no cracks or holes exist in the wall and floor. If there are cable entries in the wall or window, take proper sealing measures. Ensure that the wall is flat, wear-resistant, and dust-free, meeting standards for flame resistance, soundproofing, heat absorption, dust reduction, and electromagnetic shielding.
- Keep the door and the window closed to make the equipment room sealed.
- You are advised to use the steel door for soundproofing.
- Do not use sulfur-containing materials.
- Keep the air conditioner from blowing wind straight toward the equipment or blowing water drops from the window or air vent toward the equipment.

Contents

1 Overview	4
1.1 About the RG-ES207GS-PI-OD	4
1.2 Equipment Appearance	5
1.2.1 Front Panel.....	5
1.2.2 Bottom Cover Removal.....	6
1.2.3 Rear Panel	8
1.3 Cooling.....	8
1.4 Technical Specifications	8
2 Preparing for Installation	12
2.1 Package Contents.....	12
2.2 Safety Guidelines.....	12
2.2.1 General Precautions	12
2.2.2 Chassis-Lifting Guidelines	13
2.2.3 Electricity Safety	13
2.2.4 Preventing ESD Damage.....	14
2.2.5 Laser Safety	14
2.3 Site Requirements	15
2.3.1 Floor Loading	15
2.3.2 Airflow.....	15
2.3.3 Temperature and Humidity.....	15
2.3.4 Waterproof	15
2.3.5 Grounding	15

2.3.6 Preventing Electromagnetic Interference	15
2.3.7 Surge Protection	16
2.4 Tools	16
3 Installing the Switch	17
3.1 Installation Procedure	17
3.2 Before You Begin.....	17
3.3 Installation Precautions.....	18
3.4 Making Cables	18
3.5 Connecting Cables to the Equipment.....	19
3.6 Installing the Equipment	24
3.6.1 Pole Mount.....	24
3.6.2 Wall Mount	25
3.7 Bundling Cables.....	26
3.7.1 Precautions	26
3.7.2 Bundling Procedure	26
3.8 Verifying Installation.....	27
4 Commissioning.....	28
4.1 Power-on.....	28
4.2 Logging In to the Management Interface.....	28
5 Troubleshooting.....	29
5.1 General Troubleshooting Flowchart	29
5.2 Common Faults.....	29
6 Appendix.....	31
6.1 Connectors and Media.....	31

6.1.1 10Or100Or1000BASE-T Port	31
6.1.2 Optical Cable Connection	32
6.2 SFP Transceivers	32
6.3 Lightning Protection	35
6.3.1 Installing the AC Power Arrester (Power Strip with Surge Protection)	35
6.3.2 Installing the Ethernet Port Arrester	36
6.4 Recommended Cabling	37
6.4.1 Requirement for the Minimum Bend Radius of Cables	37
6.4.2 Precautions for Cable Bundling	37

1 Overview

1.1 About the RG-ES207GS-PI-OD

The RG-ES207GS-PI-OD Ethernet switch provides five 10/100/1000BASE-T ports, two GE SFP ports, one Reset button, and one power input port in the bottom cover. Ports 1–4 support Power over Ethernet (PoE) Out, and port 5 supports PoE In. Multiple LEDs are provided on the front panel. Designed with an IP65-rated housing, the switch is suitable for outdoor use and effectively protects against harsh weather and environmental conditions.

Figure 1-1 RG-ES207GS-PI-OD Appearance



Note

- 1GE SFP port: Supports only 1GE SFP optical transceivers (not compatible with 100 Mbps optical cables).
 - 10/100/1000BASE-T port: Supports auto-negotiation at 10 Mbps, 100 Mbps, and 1000 Mbps.
-

1.2 Equipment Appearance

1.2.1 Front Panel

Figure 1-2 Front Panel of the RG-ES207GS-PI-OD

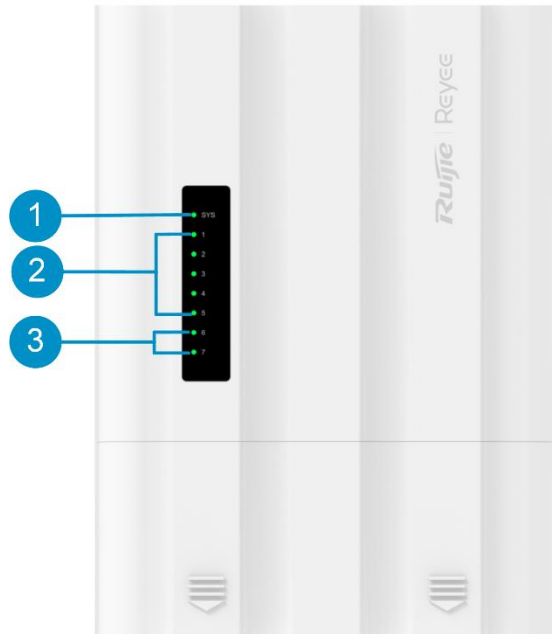
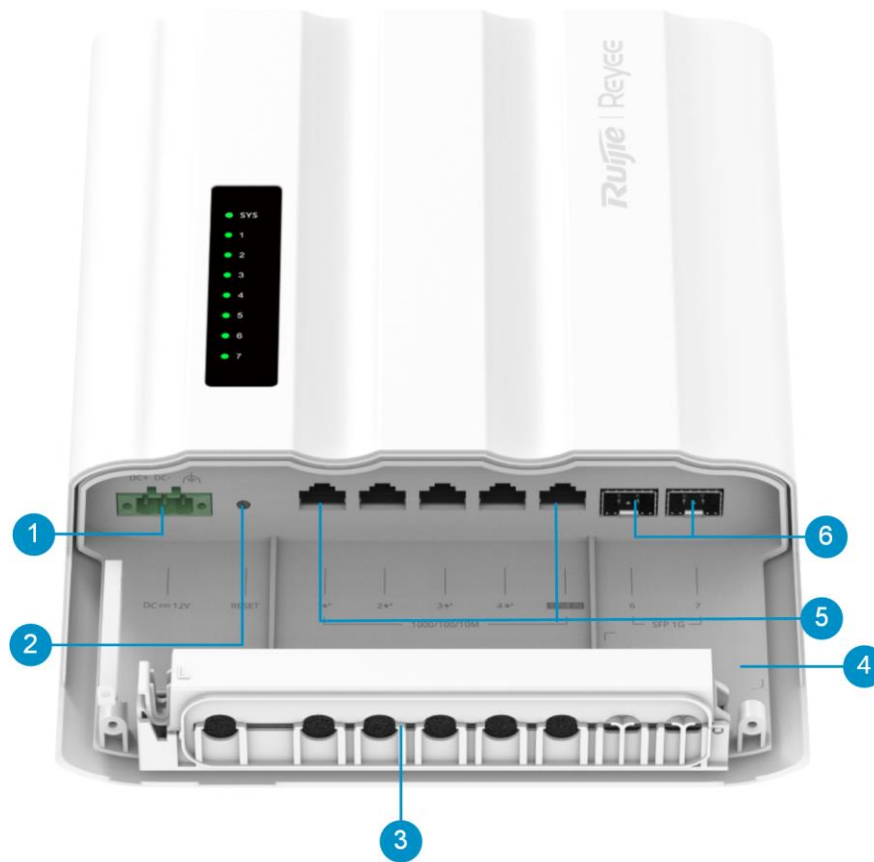

Table 1-1 Components on the Front Panel

No.	Component	Silkscreen	Description
1	System status LED	SYS	<ul style="list-style-type: none"> ● Off: The switch is not powered on. ● Slow blinking green (0.5 Hz): The switch is operating normally but is not connected to Ruijie Cloud. ● Fast blinking green (10 Hz): The switch is upgrading or restarting, and is temporarily unavailable. ● Solid green: The switch is operating normally and connected to Ruijie Cloud. ● Slow blinking yellow (0.5 Hz): The PoE power is insufficient. ● Slow blinking red (0.5 Hz): A loop occurs on the switch with loop guard enabled.
2	RJ45 port LED	1–5	<ul style="list-style-type: none"> ● Off: The port is not connected. ● Solid green: The port is operating at 1000 Mbps, 100 Mbps, or 10 Mbps, but is not receiving or sending data. ● Blinking green: The port is operating at 1000 Mbps, 100 Mbps, or 10 Mbps, and is receiving or sending data.
3	SFP port LED	6, 7	<ul style="list-style-type: none"> ● Off: The port is not connected. ● Solid green: The port is operating at 1000 Mbps, but is not receiving or sending data. ● Blinking green: The port is operating at 1000 Mbps, and is receiving or sending data.

1.2.2 Bottom Cover Removal

Figure 1-3 RG-ES207GS-PI-OD Bottom Cover Removal



Note

⚡+ indicates the PoE+ ports, which are compliant with IEEE 802.3at, and backward compatible with IEEE 802.3at.

Table 1-2 Bottom Cover Removal

No.	Component	Silkscreen	Description
1	Power input port	DC=12 V	DC power input port: right — ground, middle (DC-) — negative terminal, left (DC+) — positive terminal. Note: Regardless of PoE input (over an Ethernet cable) or DC power supply, the equipment must be connected to a grounding wire for proper operation.

No.	Component	Silkscreen	Description
2	Reset button	RESET	<ul style="list-style-type: none">● Press and hold the button for less than 2 seconds. The switch is reset.● Press and hold the button for 2–5 seconds. No action is performed.● Press and hold the button for more than 5 seconds, and release the button until the system status LED starts blinking to restore factory settings and restart the switch.
3	Cable outlet	-	It prevents water and dust from entering the equipment.
4	3-in-1 device label	-	<p>This label contains the device SN, MAC address, and QR code.</p> <hr/> <p> Note:</p> <p>Before installation, take a photo of this label. After installation, use Ruijie Reyee App to scan the QR code and bind the equipment during initial setup.</p> <hr/>
5	RJ45 port	1–5	<p>10/100/1000BASE-T ports, with ports 1–4 supporting PoE Out and port 5 supporting PoE In.</p> <p>Note: You can view the PoE status only by logging in to the switch's eWeb.</p>
6	SFP port	6, 7	1GE SFP port, supporting 1GE SFP transceiver (hot-swappable)

1.2.3 Rear Panel

Figure 1-4 Rear Panel of the RG-ES207GS-PI-OD

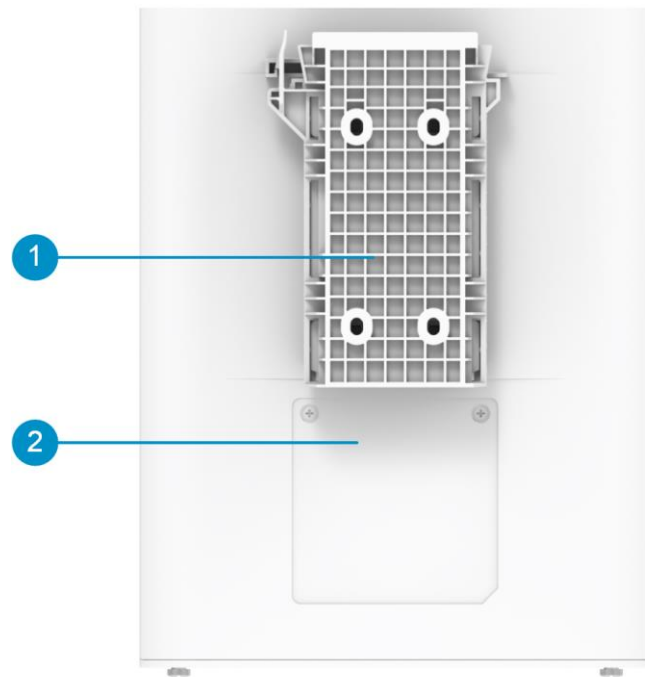

Table 1-3 Components on the Rear Panel

No.	Component	Description
1	Mounting plate	Integrated mounting plate on the equipment. It is used to install clamps for pole mount or a mounting bracket for wall mount.
2	Nameplate	Located on the rear panel.

1.3 Cooling

The RG-ES207GS-PI-OD adopts natural cooling. To ensure that the equipment works properly in the specified environment, maintain sufficient clearance around the equipment for air circulation and ventilation.

1.4 Technical Specifications

! Warning

- The equipment falls into Class A. Therefore, the equipment room should be located away from the residential area. Otherwise, the equipment room should meet construction specifications to avoid noise and radio interference.
- This equipment is not suitable for use in locations where children are likely to be present.

- Operation of this equipment in a residential environment could cause radio interference.

Table 1-4 Technical Specifications

Parameter Type	Parameter Name	RG-ES207GS-PI-OD
System Specifications	Forwarding rate	10.41 Mpps
	Switching capacity	14 Gbps(bit/s)
	Flash memory	8 MB
Port Specifications	Total number of optical ports	2
	Total number of RJ45 ports	5
	Number of 10/100/1000BASE-T ports	5
	Number of 1GE SFP ports	2
	Reset button	1
	LEDs	1 x system status LED 5 x Ethernet port LEDs 2 x SFP port LEDs
	DIP switch	NA
Power Supply and Consumption	Power supply	<ul style="list-style-type: none"> ● DC power adapter ● PoE/PoE+/PoE++ IN
	Power input	DC input: <ul style="list-style-type: none"> ● Rated voltage range: 12 V DC ● Rated current range: 0.5 A PoE In: PoE/PoE+/PoE++
	Maximum power consumption	6 W (with no PoE load) 66 W (with full PoE load)
	Number of PoE Out ports	4
	Number of PoE/PoE+ Out ports	4
	PoE Out standard	PoE/PoE+ (IEEE 802.3af/at)
	PoE power pins	1–2 (+), 3–6 (-)
	PoE budget per port	30 W

Parameter Type	Parameter Name	RG-ES207GS-PI-OD
	PoE budget	PoE input (PoE++) at 90 W: 60 W PoE input (PoE++) at 60 W: 40 W PoE input (PoE+) at 30 W: 19 W PoE input (PoE) at 15.4 W: 6 W
Dimensions and Weight	Product dimensions (W x D x H)	258mm x 200mm x 62.8mm (10.16 in. x 7.87 in. x 2.47 in.)
	Weight	0.95 kg (2.09 lbs) (without packaging materials)
	Shipping weight	1.61 kg (3.55 lbs)
	Casing	Plastic
Interface	EEE	Yes
Environment and Reliability	Mounting options	Wall/Pole
	Hot swapping of cables	Hot swapping supported by the service port and power connector
	Fan	Fanless design
	Cooling	Natural cooling
	MTBF	200,000 hours
	ESD protection	Air discharge: 8 kV Contact discharge: 6 kV
	Surge protection	Service port: ± 8 kV for common mode(port1~4) ± 2 kV for common mode(port5) Power connector: ± 2 kV for common mode
	Operating temperature	-30°C to +65°C (-22°F to 149°F)
	Storage temperature	-40°C to +70°C (-40°F to +158°F)
	Operating humidity	10% RH to 90% RH (non-condensing)
	Storage humidity	5% RH to 95% RH (non-condensing)
Altitude	-500 m to +5,000 m (-1,640.42 ft. to +16,404.20 ft.)	
Certification and Regulatory Compliance	EMC	EN 55032 EN 61000-3-2 EN 61000-3-3 EN 55035

Parameter Type	Parameter Name	RG-ES207GS-PI-OD
		EN 300 386
	Safety compliance	EN 62368-1 IEC 62368-1
	Certification	CE,CB

2 Preparing for Installation

2.1 Package Contents

Table 2-1 Package Contents

No.	Item	Quantity
1	RG-ES207GS-PI-OD switch	1
2	User Manual	1
3	Warranty Card	1
4	Terminal block	1
5	Expansion anchor	4
6	Hose clamp	2
7	Mounting bracket	1
8	ST4.2 x 19 mm screw	4

Note

The package contents are subject to the purchase contract, and actual delivery may vary. Please check the items carefully against the package contents or purchase contract. If you have any questions, please contact the distributor.

2.2 Safety Guidelines

Note

- To avoid personal injury or equipment damage, review the safety guidelines in this chapter before you begin the installation.
 - The following safety guidelines may not include all the potentially hazardous situations.
-

2.2.1 General Precautions

- Never operate the equipment in a wet environment, and avoid any liquids inside it. Keep the chassis clean and dust-free.
- Keep the equipment away from heat sources.
- Do not expose the equipment to high temperatures, dust, or harmful gases. Do not install the equipment in flammable or explosive environments. Keep the equipment away from sources of electromagnetic interference (EMI), such as large radar stations, radio stations, and substations. Do not subject the equipment to unstable voltage, vibration, or excessive noise.

- The installation site should be dry. Do not install the equipment in a place near the sea. Keep the equipment at least 500 m (1,640.42 ft.) away from the ocean and do not face it towards the sea breeze.
- The installation site should be free from water flooding, seepage, dripping, or condensation. The installation site should be selected according to network planning, communications equipment features, and considerations such as climate, hydrology, geology, earthquake, electrical power, and transportation.
- During installation and maintenance, do not wear loose clothing or ornament that may get caught in the chassis.
- Keep tools and accessories away from walk areas.

2.2.2 Chassis-Lifting Guidelines

- Avoid moving the equipment frequently.
- Turn off all power supplies and disconnect all cables before lifting or moving the equipment.

2.2.3 Electricity Safety

Warning

- Any deviation from standard or improper electrical operations can result in accidents such as fires or electric shocks, potentially causing severe or even fatal harm to both individuals and equipment.
 - Direct or indirect touch through a wet object on high-voltage and mains supply can bring a fatal danger.
 - Cut off the power supply before equipment maintenance.
-

- Always observe the local regulations and standards. Only qualified personnel should be allowed to operate the equipment.
- Carefully check the work area for potential hazards, including ungrounded power system, absent safety grounds, and damp floors.
- Locate the emergency power-off switch in the room before installation. In the case of an accident, cut off the power supply immediately.
- Never assume that power is connected to or disconnected from a circuit. Always check.
- Select the right leakage protector (also called "leakage current switch" or "leakage current breaker") for the power supply system. This equipment automatically disconnects the power supply in the event of leakage and the risk of electric shock. A leakage protector should meet the following requirements:
 - The rated leakage action current of each leakage protector must be at least twice the total maximum leakage current of all connected power supplies.

Example:

If a system has 16 identical power supplies, each with a maximum leakage current of 3.5 mA:

Total leakage current = $16 \times 3.5 \text{ mA} = 56 \text{ mA}$

For a 30 mA leakage protector:

Maximum number of power supplies per protector = $30 \text{ mA} / 2 / 3.5 \text{ mA} \approx 4$

Therefore, only four power supplies can be connected to one 30 mA leakage protector.

To support 16 power supplies, at least four 30 mA leakage protectors are required.

Always ensure:

Rated leakage operating current/2 > Total maximum leakage current of connected power supplies

- The rated leakage non-action current of a leakage protector should be 50% of the leakage action current. If the non-action current value is too small, the high sensitivity level can cause the circuit to break, leading to power cutoff and service interruption, even if the leakage current value is normal.

For example, if a leakage protector has a rated leakage action current of 30 mA, the rated leakage non-action current should be 15 mA. The leakage protector will not activate unless the leakage current exceeds 15 mA.

⚠ Caution

- To ensure personal safety, each leakage protector in the system must have a rated leakage action current equal to or below 30 mA, which is the recognized safety threshold for human body current. If the total leakage current of the system exceeds twice the 30 mA limit, the system must be equipped with two or more leakage protectors to maintain safety.
 - The leakage current values vary with equipment. For the leakage current value of each equipment model, see "[Technical Specifications](#)"
-

2.2.4 Preventing ESD Damage

- Ensure that the chassis is connected to earth ground.
- Maintain appropriate humidity conditions.
- Before installing any pluggable modules, wear an anti-ESD wrist strap and make sure that it is properly grounded.
- Avoid contact between the printed circuit boards and clothing. The anti-ESD wrist strap only protects the printed circuit boards from ESD voltages on the body. ESD voltages on clothing can still cause damage.

2.2.5 Laser Safety

The equipment supports various types of optical transceivers, which are Class 1 laser products.

Precautions:

- When an optical transceiver is working, ensure that its port is connected to an optical cable or covered by a dust cap to keep out dust and prevent it from burning your eyes.
- Do not stare into an optical port.

Figure 2-1 Laser Product ID

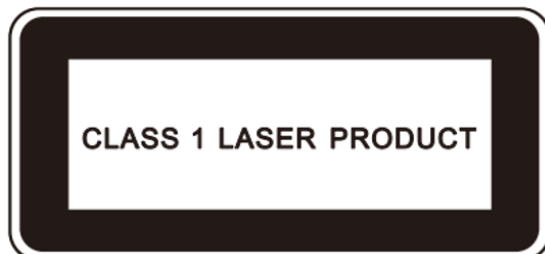

⚠ Caution

Do not approach or stare into an optical port under any circumstances. This may cause permanent damage to your eyes.

2.3 Site Requirements

To ensure the normal operation and prolonged service life of the equipment, the installation site must meet the following requirements.

2.3.1 Floor Loading

Evaluate the weight of the equipment and its accessories, and ensure that the installation site (such as a wall or a pole) can bear the weight.

2.3.2 Airflow

The equipment adopts natural cooling. Reserve a sufficient clearance around the equipment to ensure proper ventilation.

2.3.3 Temperature and Humidity

To ensure the normal operation and a prolonged service life of the equipment, maintain an appropriate temperature and humidity in the installation environment. Prolonged exposure to inappropriate temperature and humidity conditions can cause damage to the equipment.

- In an environment with high relative humidity, insulating materials are prone to poor insulation or even electricity leakage. Sometimes, high humidity may cause changes in the mechanical properties and cause rusting of metal parts.
- In an environment with low relative humidity, insulating gaskets may shrink, resulting in screw loosening.
- A high temperature can accelerate the aging process of insulation materials, greatly reducing the availability of the equipment and severely affecting its service life.

2.3.4 Waterproof

- The Ethernet cables and power cord are routed through the waterproof components before connecting to the equipment (see the following installation steps for details) to ensure waterproofing.
- The screw holes on the equipment are sealed using waterproof plugs or caps to ensure waterproof performance.

2.3.5 Grounding

A proper grounding system is crucial for ensuring stable and reliable operation, as well as preventing lightning strikes and interference. Carefully check the grounding conditions at the installation site according to the grounding requirements, and complete grounding properly based on the site situation.

2.3.6 Preventing Electromagnetic Interference

- Take interference prevention measures for the power supply system.
- Keep the equipment away from the grounding system or lightning protection grounding system of the power facility.

- Keep the equipment far away from high-frequency current equipment such as high-power radio transmitting stations and radar launchers.
- Take electromagnetic shielding measures when necessary.

2.3.7 Surge Protection

Although the equipment can guard against lightning strikes, strong lightning strikes may still damage the equipment. Take the following surge protection measures:

- Ensure that the neutral point of the AC power socket is in good contact with the ground.
- Install a power arrester in front of the power input end to enhance surge protection for the power supply.

2.4 Tools

Table 2-2 Tools

Common Tools	Phillips screwdriver, flat-blade screwdriver, cables, diagonal pliers, cable ties, and grounding wires
Dedicated Tools	Anti-ESD gloves, wire stripper, crimping pliers, RJ45 crimping pliers, and wire cutter
Meter	Multimeter

 **Note**

The equipment is delivered without a toolkit. Prepare the preceding tools by yourself.

3 Installing the Switch

⚠ Caution

Before installing the equipment, ensure that guidelines and requirements in Chapter 2 have been met.

3.1 Installation Procedure

Figure 3-1 Installation Flowchart

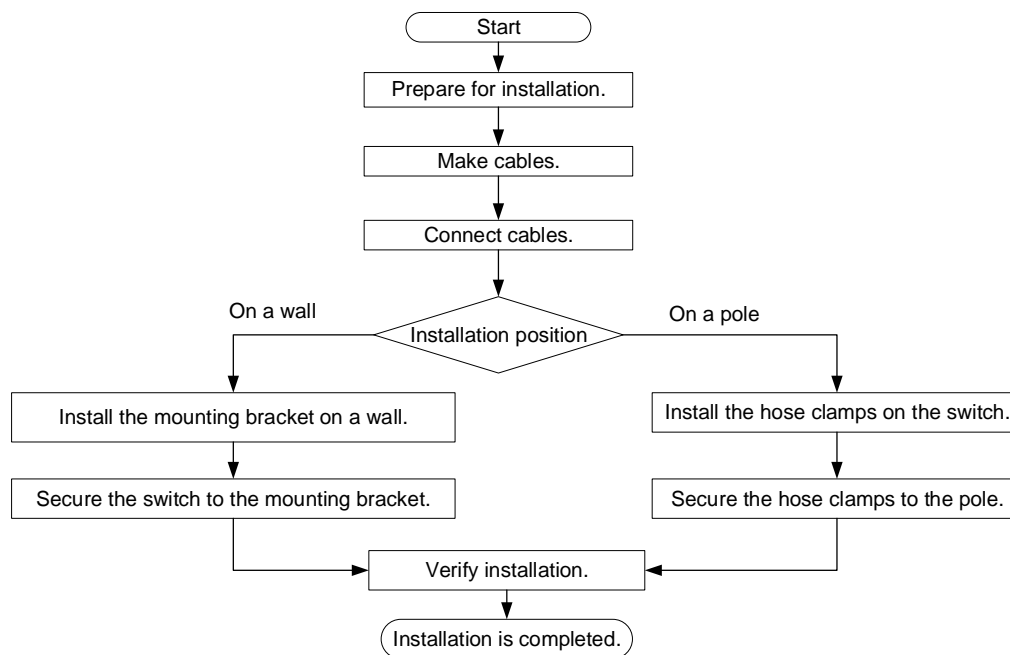

3.2 Before You Begin

Carefully plan and arrange the equipment installation position and cabling before installation. Confirm the following requirements before installation:

- The installation site provides sufficient space for heat dissipation.
- The installation site meets the temperature and humidity requirements.
- The power supply is available at the installation site, and its current meets the requirements.
- The power supply meets the requirements.
- The Ethernet cables have been deployed at the installation site.
- The installation site meets the site requirements of the equipment.

3.3 Installation Precautions

Outdoor switches can be installed on a pole or wall. The recommended diameter range of the pole is from 50 mm (1.97 in.) to 70 mm (2.75 in.). If the pole falls out of this range, you need to prepare other types of hose clamps with a thickness of no less than 2.5 mm (0.1 in.). The equipment must be installed by professionals, and the installation positions are determined by site surveys.

Before installation, ensure that the installation position meets the requirements in [3.2 Before You Begin](#) and pay attention to the following points:

- Do not power on the equipment during installation.
- Place the equipment in a well-ventilated environment.
- Do not subject the equipment to high temperatures.
- Keep the equipment away from high-voltage power cables.
- Do not expose the equipment to a thunderstorm or strong electric field.
- Cut off the power supply before cleaning the equipment.
- Do not open the enclosure when the equipment is working.
- Secure the equipment properly.
- Before installation, take a photo of the label inside the bottom cover. After installation, use Ruijie Reyee App to scan the QR code and bind the equipment during initial setup.

3.4 Making Cables

Warning

The RG-ES207GS-PI-OD supports PoE input (over an Ethernet cable) and DC power supply. You can use either power supply mode, but not both at the same time.

Regardless of PoE input (over an Ethernet cable) or DC power supply, the equipment must be connected to a grounding wire for proper operation. [Figure 3-2](#) shows the connection position of the grounding wire. Therefore, the terminal block plug must be made onsite.

Figure 3-2 Grounding Position



Caution

The diameter of the power cord must be within the range of 6.1 mm to 6.9 mm (0.24 in. to 0.27 in.). Using thicker or thinner cables may affect the dustproof and waterproof performance.

- (2) Use a wire stripper to strip about 1 cm (0.39 in.) of the insulation layer off the power cord.
 - If the DC power supply is used, all three power wires need to be stripped.
 - If PoE input (over an Ethernet cable) is used, you only need to strip the grounding wire.

Figure 3-3 Power Cord Stripping

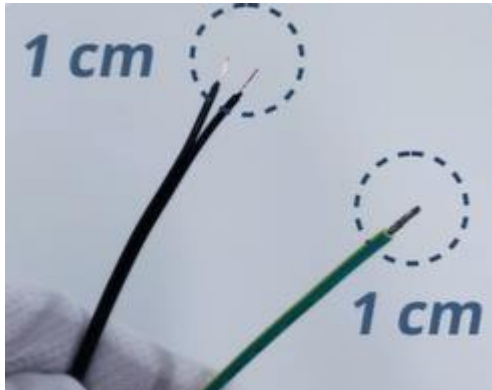

- (3) Use a flat-blade screwdriver to loosen the screws on the terminal block.
- (4) Insert the wires of the power cord into the corresponding ports of the terminal block and tighten the screws on the terminal block.
 - When the DC power supply is used, connect three power wires to a terminal block.
 - If PoE input (over an Ethernet cable) is used, connect only the grounding wire to a terminal block.

The positive, negative, and grounding wires of the power cord correspond to the markings (DC+, DC-, and ) on the power input port at the bottom of the switch, as shown in [Figure 3-4](#).

Figure 3-4 Mapping Between Power Wires and Power Input Port



3.5 Connecting Cables to the Equipment

- (1) Loosen two captive screws at the bottom of the device.

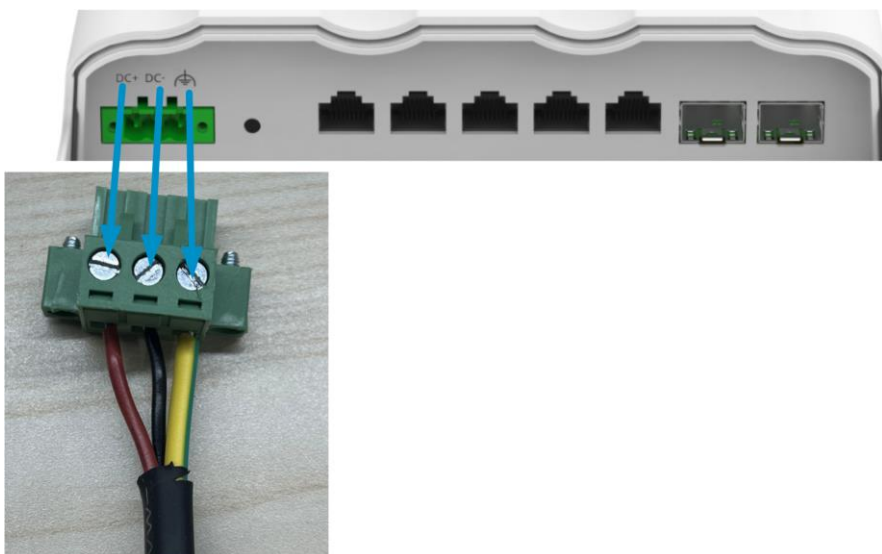
Figure 3-5 Connecting Cables to the Equipment (1)



(2) Press the upper end and sides of the bottom cover and slide it out.

Figure 3-6 Connecting Cables to the Equipment (2)

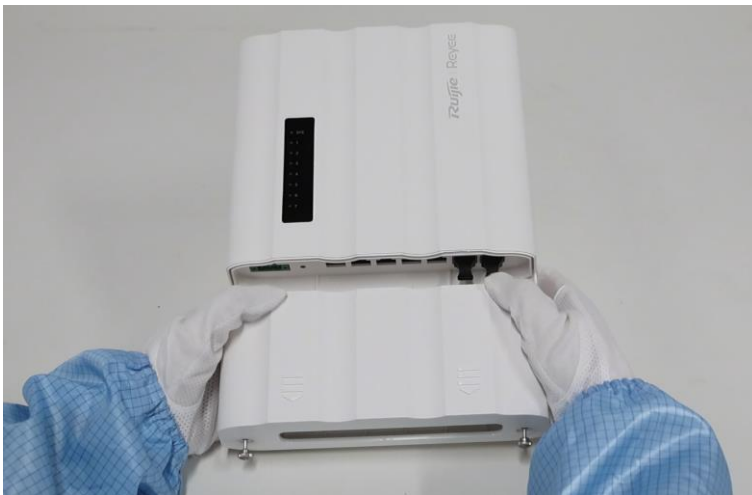

(3) Press the clip to open the upper cover.

Figure 3-7 Connecting Cables to the Equipment (2)

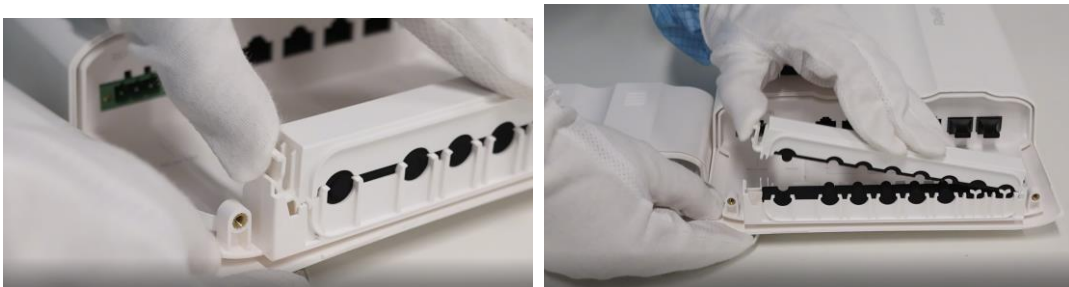

(4) Lead the power cord, Ethernet cables, and optical cables through the cable holes at the bottom cover.

⚠ Caution

- The diameter of a connected Ethernet cable must be within the range of 6.1 mm to 6.9 mm (0.24 in. to 0.27 in.). Using thicker or thinner cables does not guarantee dustproof and waterproof performance.
- The diameter of a fiber jumper used with the optical transceiver must be within the range of 2.8 mm to 3.2 mm (0.11 in. to 0.13 in.). Using thicker or thinner cables does not guarantee dustproof or waterproof performance.

Figure 3-8 Connecting Cables to the Equipment (3)

- (5) Connect the power cord, Ethernet cables, and optical cables.
 - a Connect the cables to the corresponding ports.

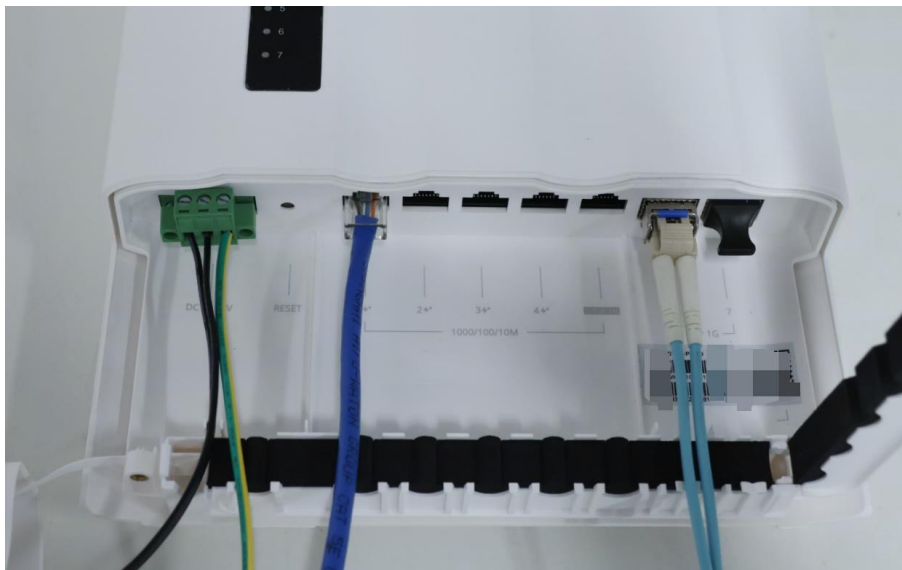
Figure 3-9 Connecting Cables to the Equipment (4)

- b Remove the peelable silicone fillers from the cable positions based on the cable positions and quantity.

Figure 3-10 Connecting Cables to the Equipment (5)

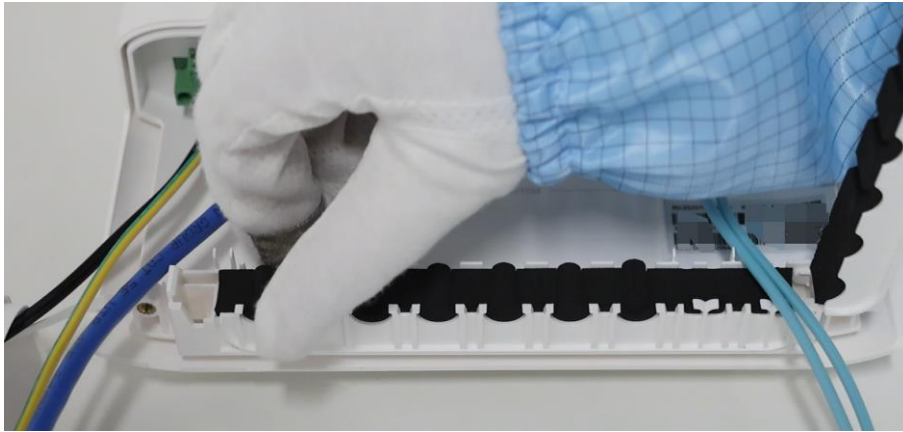

- c Secure the cables in the grooves.

Figure 3-11 Connecting Cables to the Equipment (6)

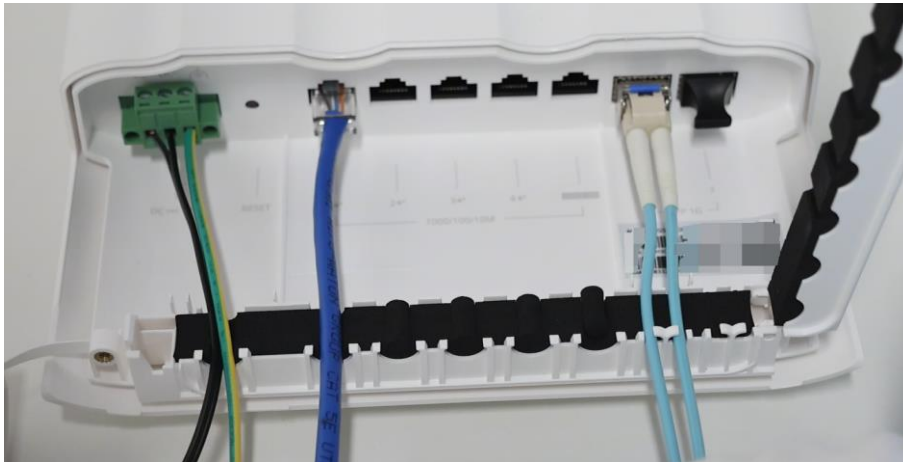

- (6) Close the cover.

Figure 3-12 Connecting Cables to the Equipment (7)

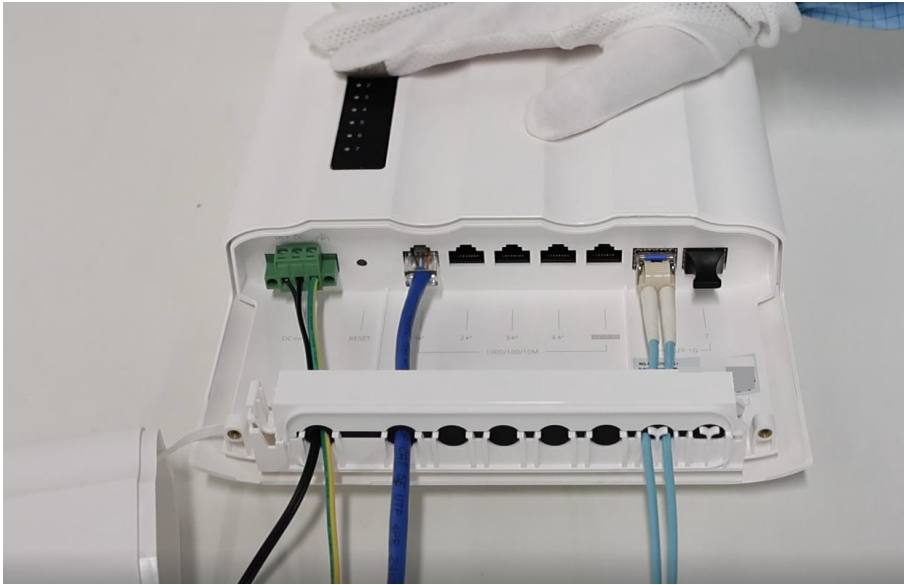

(7) Arrange the cables to ensure correct positioning and proper sealing.

Figure 3-13 Connecting Cables to the Equipment (8)

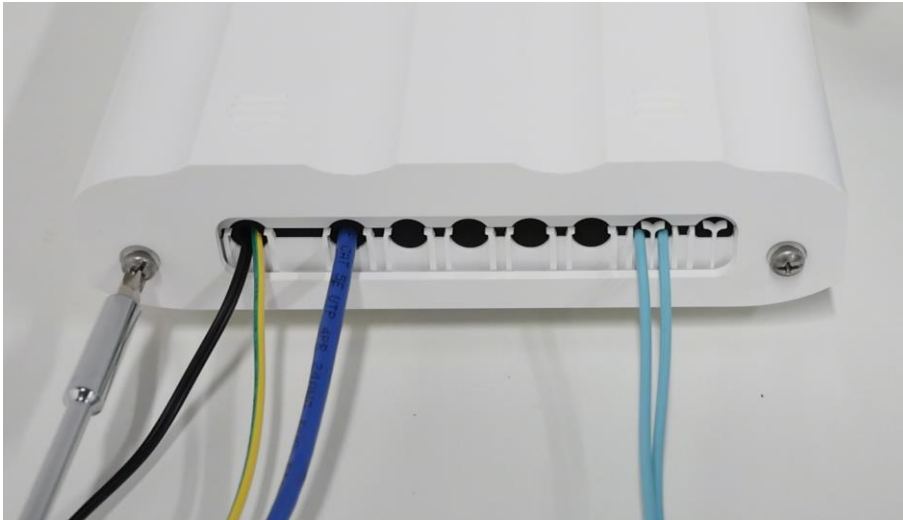

(8) Install the bottom cover and tighten the captive screws.

Figure 3-14 Connecting Cables to the Equipment (9)

3.6 Installing the Equipment

3.6.1 Pole Mount

- (1) Take two hose clamps out of the accessories, and loosen the fastening screws on the clamps until the end of the clamps is disengaged.
- (2) Thread the end of the clamps through the bracket holes on the rear of the equipment.

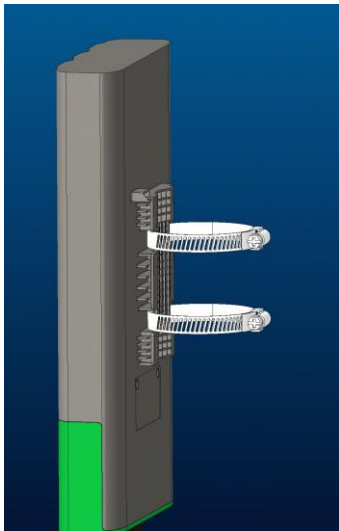
Figure 3-15 Installing Clamps on the Rear of the Equipment

- (3) Install clamps at appropriate positions on the pole, and tighten the screws on the clamps to secure the equipment.

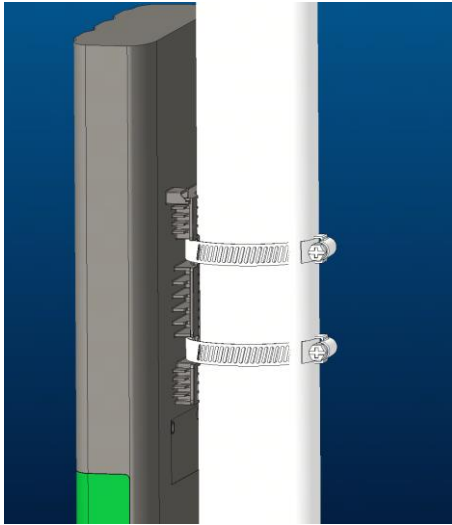
Figure 3-16 Securing the Equipment to the Pole

3.6.2 Wall Mount

To mount the switch on a wall, use the delivered mounting bracket, ST4.2 x 19 mm screws, and expansion anchors. The steps are as follows:

- (1) Drill four screw holes (spacing: 30 mm [1.18 in.] horizontally and 78 mm [3.07 in.] vertically) on the wall at appropriate positions according to the hole spacing on the mounting bracket.

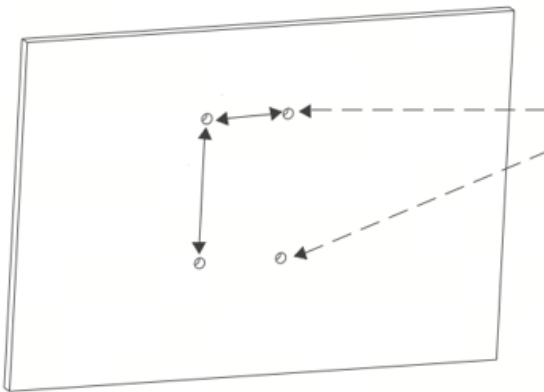
Figure 3-17 Drilling Holes on the Wall

- (2) Insert the four expansion anchors into the holes.
- (3) Secure the mounting bracket to the wall with four ST4.2 x 19 mm screws.

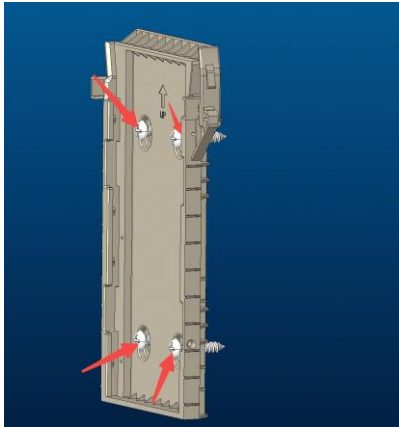
Figure 3-18 Fastening the Mounting Bracket

(4) Align the rear mounting plate of the equipment with the mounting bracket, and push the equipment downward.

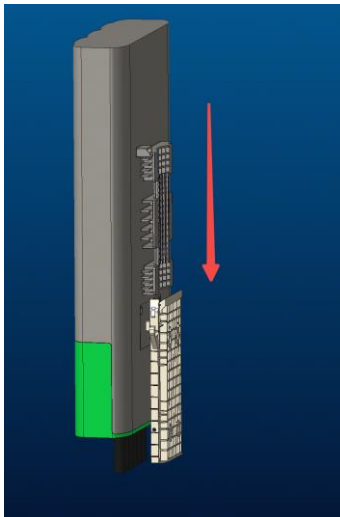
Figure 3-19 Securing the Equipment

3.7 Bundling Cables

3.7.1 Precautions

- Bundle the power cord and other cables in an esthetically pleasing way.
- Make sure that the optical cables at the connectors have natural bends or bends of large radius.
- Do not bind optical cables and twisted pairs too tightly, as this may press the cables and affect their service life and transmission performance.

3.7.2 Bundling Procedure

- (1) Bind the drooping part of the optical cables and twisted pairs, and lead them to both sides of the chassis for convenience.
- (2) Bind the power cord closely along the bottom of the chassis, in a straight line wherever possible.

3.8 Verifying Installation

 **Caution**

Please turn off the power to avoid personal injury and damage to components caused by incorrect connection.

- Verify that the cables including power cords are properly connected.
- Verify that there is adequate clearance around the equipment.

4 Commissioning

4.1 Power-on

- (1) Checklist Before Power-on
 - The switch is properly grounded.
 - The power cord is properly connected.
 - The power supply voltage meets the requirement of the switch.
- (2) Checklist After Power-on (Recommended)
 - The switch LEDs are in the normal state.
 - Service ports can forward data properly.

4.2 Logging In to the Management Interface

- (1) Connect a PC to an Ethernet port on the switch through an Ethernet cable.
- (2) Set the IP address of the PC to 10.44.77.XXX (Range: 1–254, excluding 200).

Figure 4-1 Changing the IP Address

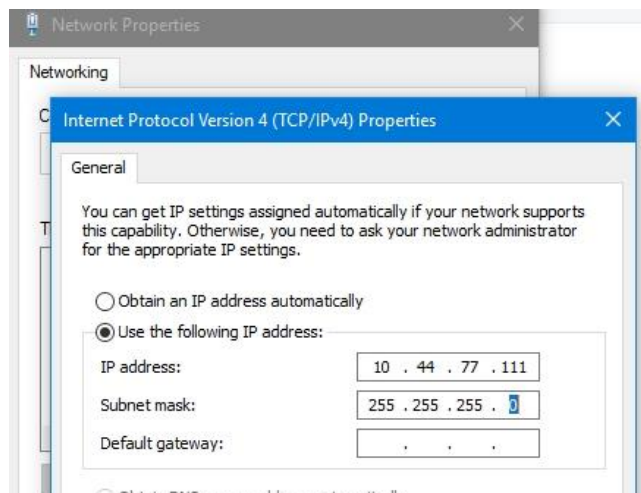

- (3) Open a browser, enter 10.44.77.200 in the address bar, and press Enter. On the login page, set a password and log in.
- (4) Perform equipment commissioning and configuration based on service requirements.

Note

For security purposes, you are advised to change the password regularly.

5 Troubleshooting

5.1 General Troubleshooting Flowchart

Note

You can determine whether each checking item in the process is normal based on the information provided in the previous chapters "Overview" and "Installing the Switch."

Figure 5-1 General Troubleshooting Flowchart

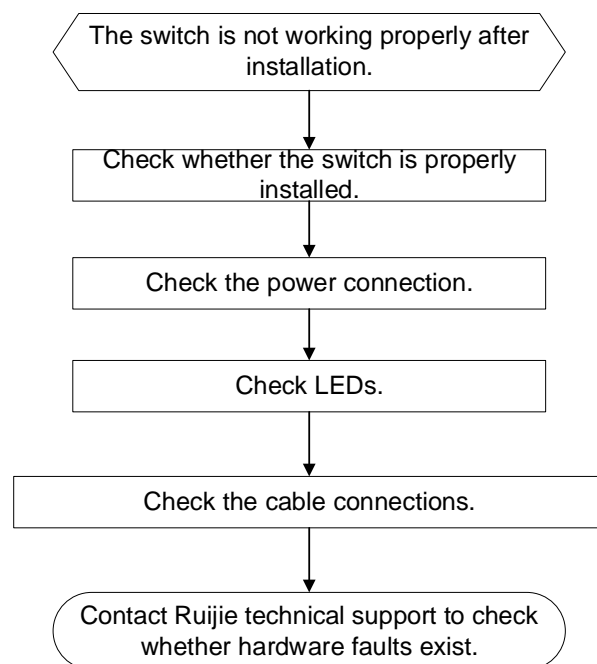

5.2 Common Faults

Table 5-1 Common Faults and Troubleshooting

Symptom	Possible Cause	Suggested Action
The system status LED is off after the switch is powered on.	No power is supplied to the switch or the power cord is loosely connected.	Check whether the power supply is normal and whether the power cord is loosely connected to the switch.
An RJ45 port is disconnected or a frame	The twisted pair is not connected properly.	Replace the twisted pair.

Symptom	Possible Cause	Suggested Action
sending/receiving error occurs.	The cable length exceeds 100 m (328.08 ft.).	Use an optical cable for data transmission or connect to an intermediate switch for relay.
	The port is specially configured and does not work in the same mode as that of the interconnected switch.	Check whether the port is configured to work in the same mode as that of the interconnected switch.
An optical port is not reachable.	The transmit and receive ends are connected incorrectly.	Exchange the transmit and receive ends of the optical cable.
	The types of the interconnected optical transceivers do not match.	Replace with one compatible optical transceiver.
	The optical cable type does not meet the requirements.	Replace the optical cable with a qualified one.
	The optical cable length is beyond the allowed length marked on the optical transceiver.	Use an optical cable with the required length.
	The optical cable or connector is contaminated.	Clean the connector with a lint-free cloth or a cleaning pen.
The login password cannot be retrieved.	The password is forgotten, and the equipment is not connected to the network or Ruijie Cloud.	Press and hold the Reset button to restore to factory settings.
	If the equipment is connected to Ruijie Cloud or a network, its login password is updated to the project or global management password.	If the equipment is connected to the cloud, log in using the project management password. If the equipment is connected to a network, log in using the global management password.

6 Appendix

6.1 Connectors and Media

6.1.1 100r100Or1000BASE-T Port

The 10/100/1000BASE-T port supports auto-negotiation for 10 Mbps, 100 Mbps, and 1000 Mbps connections and also supports auto MDI/MDIX Crossover.

Compliant with IEEE 802.3ab, a 1000BASE-T port connects to a 100-ohm Category 5 (CAT5) or Category 5 Enhanced (CAT5e) Unshielded Twisted Pair (UTP), or recommended Shielded Twisted Pair (STP) cable with a maximum distance of 100 m (328.08 ft.).

The 1000BASE-T port requires that all four pairs of wires be connected for data transmission. [Figure 6-1](#) shows twisted pair connections for the 1000BASE-T port.

Figure 6-1 Twisted Pair Connections for a 1000BASE-T Port

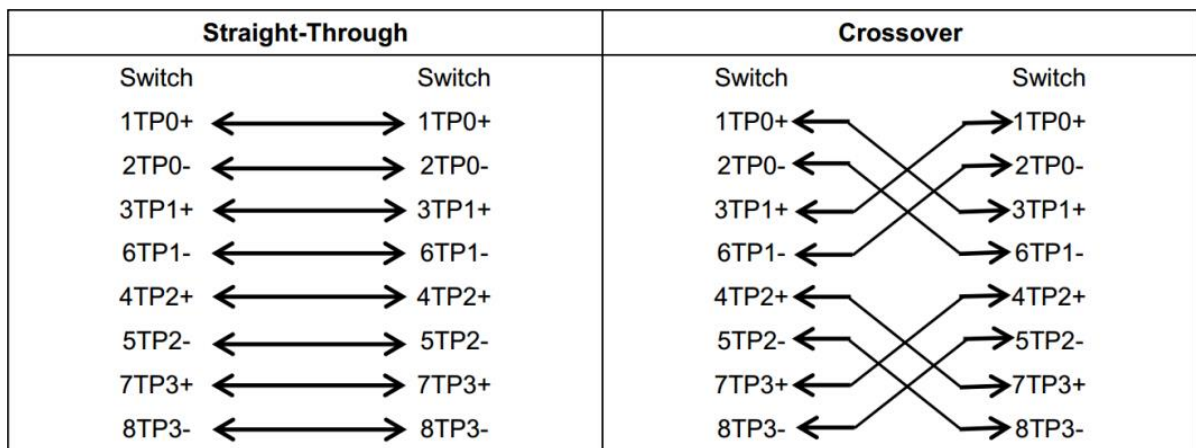

In addition to cables with the above-mentioned specifications, the 10/100BASE-T port can also be connected using 100-ohm CAT3, CAT4, and CAT5 cables at 10 Mbps or using 100-ohm CAT5 cables with a maximum distance of 100 m (328.08 ft.). The following table shows pin assignments for a 10/100BASE-T port.

Table 6-1 10/100BASE-T Pin Assignment

Pin	Socket	Plug
1	Input Receive Data+	Output Transmit Data+
2	Input Receive Data-	Output Transmit Data-
3	Output Transmit Data+	Input Receive Data+
6	Output Transmit Data-	Input Receive Data-
4, 5, 7, and 8	Not Used	Not Used

The following table shows wiring of straight-through and crossover cables for a 10/100BASE-T port.

Figure 6-2 Twisted Pair Connections for a 10/100BASE-T Port

Straight-Through		Crossover	
Switch	Adapter	Switch	Switch
1 IRD+	1 OTD+	1 IRD+	1 OTD+
2 IRD-	2 OTD-	2 IRD-	2 OTD-
3 OTD+	3 IRD+	3 OTD+	3 IRD+
6 OTD-	6 IRD-	6 OTD-	6 IRD+

6.1.2 Optical Cable Connection

Select a single-mode fiber (SMF) or multimode fiber (MMF) for connections based on the type of the optical transceiver inserted into an optical port. [Figure 6-3](#) shows the connections.

Figure 6-3 Connecting the Optical Cables

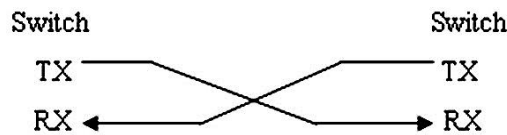

6.2 SFP Transceivers

Ruijie provides SFP transceivers (mini-GBIC) based on the port types. You can select one that suits your specific needs.

The RG-ES207GS-PI-OD is an outdoor switch and its operating temperature ranges from -30°C to +65°C (-22°F to +149°F). When the outdoor temperature is lower than 0°C (32°F) or higher than 40°C (104°F), you are advised to use an industrial-grade optical transceiver on the equipment. When the outdoor temperature ranges from 0°C (32°F) to 40°C (104°F), the following recommended optical transceivers can be used.

In addition to the following 1GE SFP transceivers, the 1GE copper transceiver Mini-GBIC-GT is also supported. This document provides models and technical specifications of some 1GE SFP transceivers for reference. For details about the technical specifications, see *Ruijie Transceiver Installation and Reference Guide*.

Table 6-2 1GE Mini-GBIC (SFP) Models and Technical Specifications

Model	Wavelength (nm)	Fiber Type	DDM Supported (Yes/No)	Transmit Power (dBm)		Receive Power (dBm)	
				Min	Max	Min	Max
MINI-GBIC-SX-MM850	850	MMF	Yes	-9	-3	-20	-3
MINI-GBIC-LX-SM1310	1310	SMF	Yes	-9	-3	-26	0
GE-SFP-LH40-SM1310-	1310TX/1550RX	SMF	Yes	-3	3	-25	0

Model	Wavelength (nm)	Fiber Type	DDM Supported (Yes/No)	Transmit Power (dBm)		Receive Power (dBm)	
				Min	Max	Min	Max
BIDI							
GE-SFP-LH40-SM1550-BIDI	1550TX/1310RX	SMF	Yes	-3	3	-25	0
GE-SFP-LX20-SM1310-BIDI	1310TX/1550RX	SMF	Yes	-8	-3	-23	-3
GE-SFP-LX20-SM1550-BIDI	1550TX/1310RX	SMF	Yes	-8	-3	-23	-3
MINI-GBIC-LH40-SM1310	1310	SMF	Yes	-5	0	-25	-3
MINI-GBIC-ZX80-SM1550	1550	SMF	Yes	-3	3	-26	-3
GE-SFP-LX03-SM1310-BIDI-I	1310TX/1550RX	SMF	Yes	-9	-3	-22	-3
GE-SFP-LX03-SM1550-BIDI-I	1550TX/1310RX	SMF	Yes	-9	-3	-22	-3
SFP-MM850	850	MMF	Yes	-9.5	-3	-17	-3
SFP-SM1310	1310	SMF	Yes	-9	-3	-20	-3

Table 6-3 1GE SFP Copper Transceivers

Standard	1000BASE-T SFP Module	DDM Supported (Yes/No)
1000BASE-T	Mini-GBIC-GT	No

Table 6-4 Cabling Specifications of SFP Transceivers

SFP Transceiver Model	Port Type	Fiber Type	Core Size (µm)	Max Cabling Distance
SFP-SM1310	LC	SMF	9/125	10 km (6.21 miles)
MINI-GBIC-LX-SM1310	LC	SMF	9/125	10 km (6.21 miles)
GE-SFP-LH40-SM1310-BIDI	LC	SMF	9/125	40 km (24.85 miles)
GE-SFP-LH40-SM1550-BIDI	LC	SMF	9/125	40 km (24.85 miles)
GE-SFP-LX20-SM1310-BIDI	LC	SMF	9/125	20 km (12.43 miles)
GE-SFP-LX20-SM1550-BIDI	LC	SMF	9/125	20 km (12.43 miles)

SFP Transceiver Model	Port Type	Fiber Type	Core Size (µm)	Max Cabling Distance
MINI-GBIC-LH40-SM1310	LC	SMF	9/125	40 km (24.85 miles)
MINI-GBIC-ZX80-SM1550	LC	SMF	9/125	80 km (49.71 miles)
GE-SFP-LX03-SM1310-BIDI-I	LC	SMF	9/125	3 km (1.86 miles)
GE-SFP-LX03-SM1550-BIDI-I	LC	SMF	9/125	3 km (1.86 miles)
MINI-GBIC-SX-MM850	LC	MMF	62.5/125	275 m (902.23 ft.)
			50/125	550 m (1,804.46 ft.)
SFP-MM850	LC	MMF	62.5/125	275 m (902.23 ft.)
			50/125	550 m (1,804.46 ft.)
Mini-GBIC-GT	RJ45	CAT5 or better UTP or STP cable		100 m (328.08 ft.)

⚠ Caution

- For optical transceivers with a cabling distance of no less than 40 km (24.85 miles), install an optical attenuator to avoid overload on an optical receiver when using short-distance SMFs.
- An optical transceiver is a laser transmitter. Do not look into the light source to prevent it from burning your eyes.
- To keep the optical transceiver clean, make sure that the unused ports remain capped.

Table 6-5 BIDI Optical Transceiver Pairing

Rate/Distance	Pairing Model
1000 Mbps/3 km (1.86 miles)	GE-SFP-LX03-SM1310-BIDI-I GE-SFP-LX03-SM1550-BIDI-I
1000 Mbps/20 km (12.43 miles)	GE-SFP-LX20-SM1310-BIDI GE-SFP-LX20-SM1550-BIDI
1000 Mbps/40 km (24.85 miles)	GE-SFP-LH40-SM1310-BIDI GE-SFP-LH40-SM1550-BIDI

⚠ Caution

BIDI optical transceivers must be used in pairs. For example, if GE-SFP-LX20-SM1310-BIDI is used at one end, GE-SFP-LX20-SM1550-BIDI must be used at the other end.

6.3 Lightning Protection

6.3.1 Installing the AC Power Arrester (Power Strip with Surge Protection)

When an alternating current (AC) power cord is introduced from outdoors and directly connected to the AC power port of the switch, the power port must be connected to an external power arrester to safeguard the switch against lightning strikes. The power arrester can be fixed on the rack, workbench, or wall in the equipment room by using cable ties and screws. AC power enters the power arrester before entering the switch.

Figure 6-4 Power Arrester

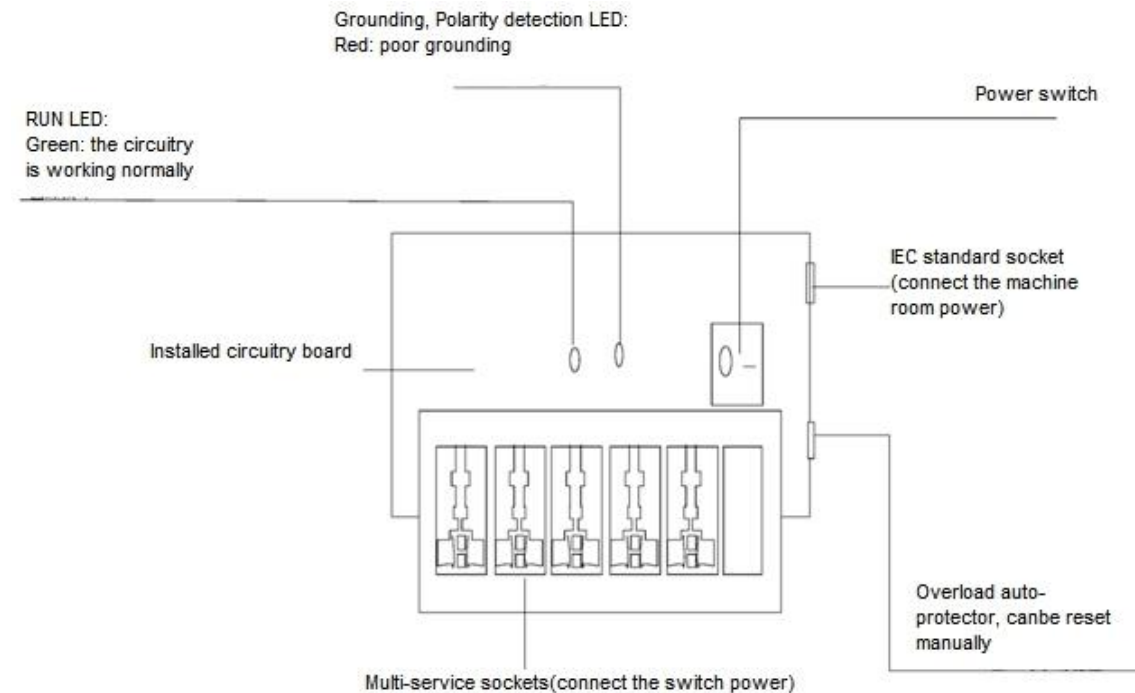

⚠ Caution

The power arrester is not delivered with the equipment. Please purchase it based on actual requirements.

Precautions during the installation:

- Make sure that the PE terminal of the power arrester is well grounded.
- After the AC power plug of the switch is connected to the socket of the power arrester, the lightning protection function is implemented only if the running status LED is green and the alarm LED is off.
- If the alarm LED on the power arrester is red, check whether it is caused by a poor grounding connection or by the reversed connection of the neutral and live wires. The detection method is as follows: Use a multimeter to measure the polarity of the power arrester when the alarm LED is red. If the neutral wire is on the left and the live wire is on the right (facing the socket), the PE terminal of the power arrester is not grounded. If not, the polarity of the power arrester should be reversed. In this case, open the power arrester and reverse its polarity. If the alarm LED is still red, the PE terminal of the power arrester is not grounded.

6.3.2 Installing the Ethernet Port Arrester

Please connect an Ethernet port arrester to the switch to prevent the damage by lightning strikes before connecting an outdoor Ethernet cable to the switch.

- Tools: Phillips screwdriver or flat-blade screwdriver, multimeter, and diagonal pliers
- Installation steps
 - a Tear one side of the protective paper for the double-sided adhesive tape and paste the tape to the enclosure of the Ethernet port arrester. Tear the other side of the protective paper for the double-sided adhesive tape and paste the Ethernet port arrester to the switch enclosure. The paste position for the Ethernet port arrester should be as close to the grounding lug of the switch as possible.
 - b Based on the distance between the grounding lug of the switch and the Ethernet port arrester, cut the grounding cable of the Ethernet port arrester and firmly tighten the grounding cable to the grounding lug of the switch.
 - c Use a multimeter to check whether the grounding cable for the arrester is in good contact with the grounding lug and the enclosure of the switch.
 - d Connect the Ethernet port arrester by using an adapter cable (note that the external Ethernet cable is connected to the IN end, while the adapter cable connected to the switch is connected to the OUT end) and check whether the module LED is normal.
 - e Use a nylon cable tie to bind the cables.

Figure 6-5 Installing an Ethernet Port Arrester

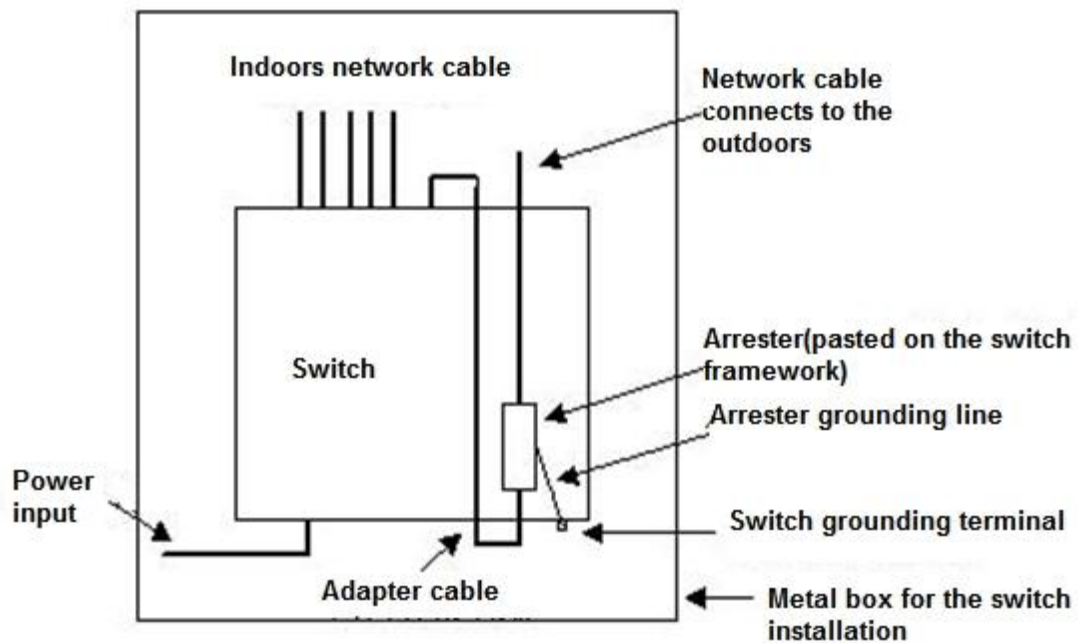

⚠ Caution

- The Ethernet port arrester is only for a 10 Mbps, 100 Mbps, or 1000 Mbps RJ45 port.

- The Ethernet port arrester is not delivered with the equipment. Please purchase it based on actual requirements. The user manual for Ethernet port arresters contains technical parameters and maintenance and installation instructions. Carefully read this manual during installation.
-

Pay attention to the following situations during the actual installation to avoid influencing the performance of an Ethernet port arrester:

- The arrester is incorrectly connected to the cables. Connect the external Ethernet cable to the IN end and connect the Ethernet port of the switch to the OUT end.
- The Ethernet port arrester is incorrectly grounded. The grounding cable of the arrester should be as short as possible to ensure that it is in good contact with the grounding lug of the switch. Use a multimeter to confirm the contact condition after grounding.
- Not all Ethernet ports are installed with Ethernet port arresters. If outdoor Ethernet cables connect the switch ports to the peer equipment, Ethernet port arresters need to be installed on all the ports for the purpose of lightning protection.

6.4 Recommended Cabling

When the switch is installed in a standard 19-inch cabinet, secure the cables around the cable management brackets. Top cabling or bottom cabling is adopted according to the actual situation in the equipment room. All adapted connectors should be placed at the bottom of the rack in an orderly manner instead of outside the rack that is easy to touch. Power cords are routed beside the rack. Top cabling or bottom cabling is adopted according to the actual situation in the equipment room, such as the positions of the DC power distribution box, AC socket, or lightning protection box.

6.4.1 Requirement for the Minimum Bend Radius of Cables

- The bend radius of a fixed power cord, Ethernet cable, and flat cable should be over five times greater than their respective external diameters. The bend radius of these cables that are often bent or plugged should be over seven times greater than their respective external diameters.
- The bend radius of a fixed common coaxial cable should be over seven times greater than its external diameter. The bend radius of these cables that are often bent or plugged should be over 10 times greater than their respective external diameters.
- The minimum bend radius of a high-speed cable, such as an SFP+ cable, should be 5 times the overall diameter of the cable. If the cable is constantly bent, plugged or unplugged, the bend radius should be 10 times the overall diameter.
- The minimum bend radius of optical cables should meet the following requirements.
 - The diameter of the optical cable tray should be no less than 25 times greater than that of the optical cable.
 - When an optical cable is moved, its bend radius should be no less than 20 times greater than its diameter.
 - During cabling of an optical cable, its bend radius should be no less than 10 times greater than its diameter.

6.4.2 Precautions for Cable Bundling

- Before cables are bundled, mark labels and stick the labels to cables wherever appropriate.

- Cables should be neatly and properly bundled in the rack without twisting or bending, as shown in [Figure 6-6](#).

Figure 6-6 Bundling Cables (1)

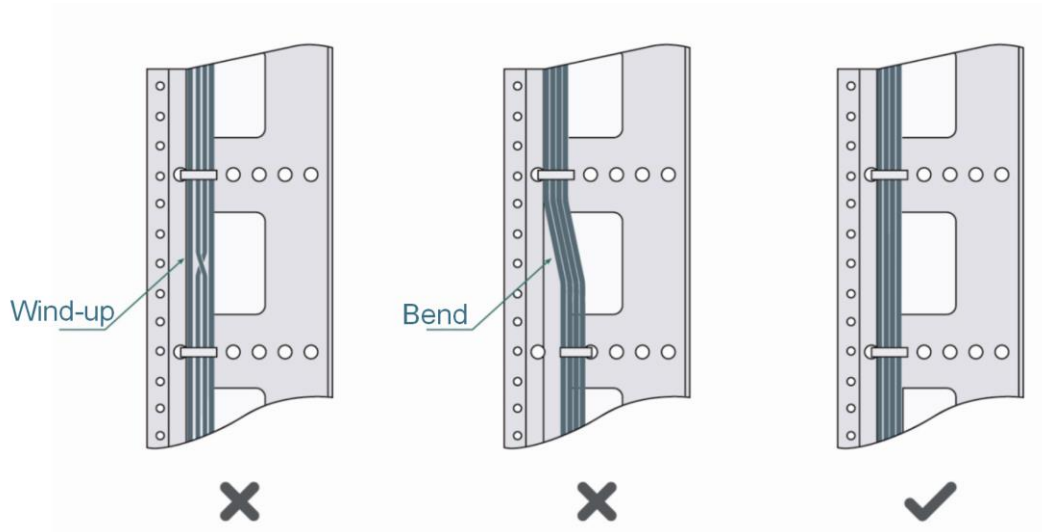

- Cables of different types (such as power cords, signal cables, and grounding wires) should be separated in cabling and bundling. Mixed bundling is not allowed. When they are close to each other, you are advised to adopt crossover cabling. In the case of parallel cabling, maintain a minimum distance of 30 mm (1.18 in.) between power cords and signal cables.
- The cable management brackets and cabling troughs inside and outside the rack should be smooth without sharp corners.
- The metal holes traversed by cables should have a smooth and fully rounded surface or an insulated lining.
- Use cable ties to bundle cables properly. Please do not connect two or more cable ties to bundle cables.
- After bundling up cables with cable ties, cut off the remaining part. The cut should be smooth and trim without sharp corners, as shown in [Figure 6-7](#).

Figure 6-7 Bundling Cables (2)

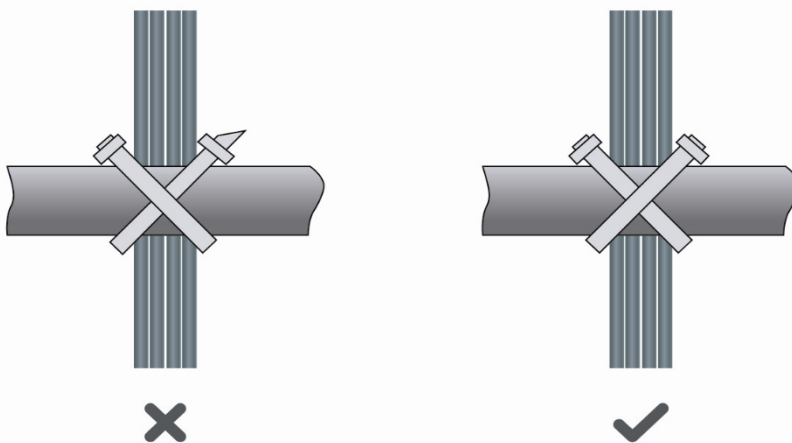

- When cables need to be bent, bundle them first but do not tie cables within the bend. Otherwise, stress may be generated on the cables and cause the wires inside to break, as shown in [Figure 6-8](#).

Figure 6-8 Bundling Cables (3)

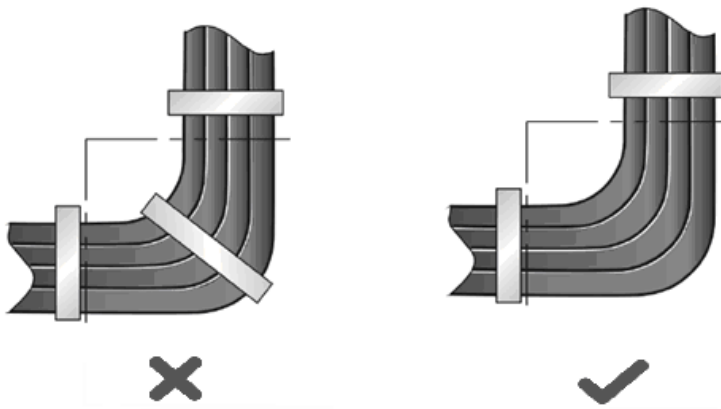

- Cables not to be assembled or the remaining parts of cables should be folded and placed in a proper position of the rack or cable management trough. The proper position refers to a position that does not affect the equipment running or damage the equipment or cables.
- Power cords must not be bundled on the guide rails of moving parts.
- The power cords connecting moving parts such as door grounding wires should be reserved with some excess after being assembled to avoid suffering tension or stress. When a moving part reaches the installation position, the remaining cable part should not touch heat sources, sharp corners, or sharp edges. If heat sources must be touched, high-temperature cables should be used.
- When using screw threads to secure a cable lug, ensure that the bolt or screw is properly tightened and take measures to prevent it from loosening, as shown in [Figure 6-9](#).

Figure 6-9 Fastening Cables

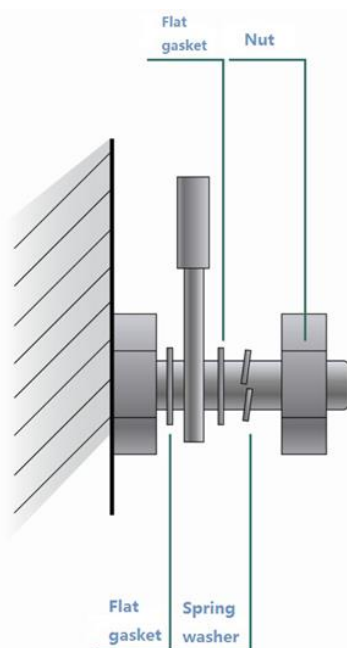

- Hard power cords should be secured near the cable termination area to prevent stress on the cable termination area and cables.
- Do not use tapping screws to secure cable lugs.
- Power cords of the same type and in the same cabling direction should be bundled up into cable bunches, with cables in cable bunches clean and straight.
- Bundle cables by using cable ties according to the following table.

Cable Bunch Diameter	Bundling Spacing
10 mm (0.39 in.)	80–150 mm (3.15–5.91 in.)
10–30 mm (0.39–1.18 in.)	150–200 mm (5.91–7.87 in.)
30 mm (1.18 in.)	200–300 mm (7.87–11.81 in.)

- Do not tie cables or bundles in a knot.

For wiring terminal blocks (such as circuit breakers) with cord end terminals, the metal part of the cord end terminal should not be exposed outside the terminal block when assembled.

Contents

1 Overview	4
1.1 About the RG-ES208GC-V2	4
1.2 Equipment Appearance	4
1.2.1 Front Panel.....	4
1.2.2 Rear Panel	5
1.2.3 LEDs	6
1.3 Cooling.....	6
1.4 Technical Specifications	6
2 Preparing for Installation	9
2.1 Package Contents.....	9
2.2 Safety Guidelines.....	9
2.2.1 General Precautions	9
2.2.2 Chassis-Lifting Guidelines	9
2.2.3 Electricity Safety	10
2.2.4 Preventing ESD Damage.....	11
2.3 Site Requirements	11
2.3.1 Floor Loading	11
2.3.2 Airflow.....	11
2.3.3 Space	11
2.3.4 Temperature and Humidity.....	11
2.3.5 Cleanliness.....	11
2.3.6 Grounding	12
2.3.7 Preventing Electromagnetic Interference	13

2.3.8 Surge Protection	13
2.3.9 Installation Site.....	13
2.4 Tools	14
3 Installing the Switch	15
3.1 Before You Begin.....	15
3.2 Installing the Switch	15
3.2.1 Wall Mount	15
3.2.2 Workbench Mount.....	16
3.3 Grounding the Equipment.....	16
3.4 Connecting Cables.....	17
3.5 Bundling Cables.....	17
3.5.1 Precautions	17
3.5.2 Bundling Procedure	17
3.6 Verifying Installation.....	17
4 Commissioning.....	18
4.1 Power-on.....	18
4.2 Logging In to the Management Interface.....	18
5 Troubleshooting.....	19
5.1 General Troubleshooting Flowchart	19
5.2 Common Faults.....	19
6 Appendix.....	21
6.1 Connectors and Media.....	21
6.1.1 10Or100Or1000BASE-T Port	21
6.2 Lightning Protection	22

6.2.1 Installing the AC Power Arrester (Power Strip with Surge Protection)	22
6.2.2 Installing the Ethernet Port Arrester	23
6.3 Recommended Cabling	25
6.3.1 Requirement for the Minimum Bend Radius of Cables	25
6.3.2 Precautions for Cable Bundling	25
6.4 Site Selection	28

1 Overview

1.1 About the RG-ES208GC-V2

The RG-ES208GC-V2 Ethernet switch provides eight 10/100/1000BASE-T ports, one Reset button, and several LEDs on the front panel, along with a 5 V DC power port and a grounding stud on the rear panel.

Figure 1-1 RG-ES208GC-V2 Appearance

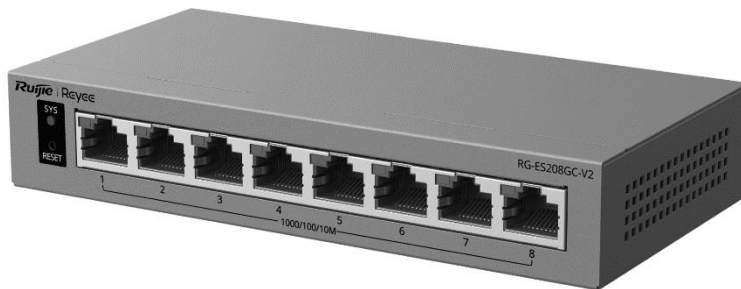

Note

10/100/1000BASE-T port: Supports auto-negotiation at 10 Mbps, 100 Mbps, and 1000 Mbps.

1.2 Equipment Appearance

1.2.1 Front Panel

Figure 1-2 Front Panel of the RG-ES208GC-V2

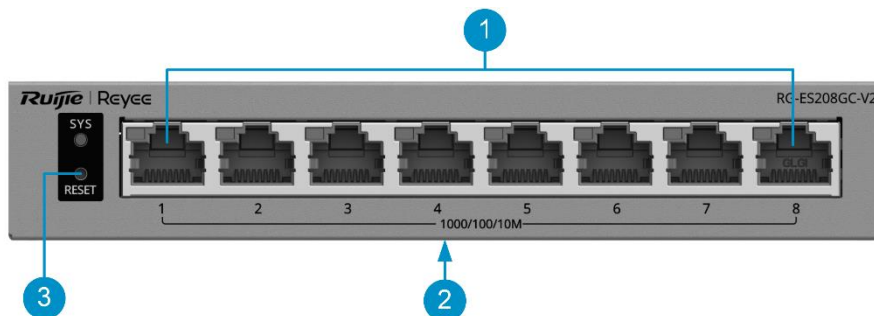

Table 1-1 Components on the Front Panel

No.	Component	Silkscreen	Description
1	RJ45 port	1–8	10/100/1000BASE-T ports

No.	Component	Silkscreen	Description
2	Nameplate	-	It is located at the bottom of the switch.
3	Reset button	RESET	<ul style="list-style-type: none"> ● Press and hold the button for less than 2 seconds. The switch is reset. ● Press and hold the button for 2–5 seconds. No action is performed. ● Press and hold the button for more than 5 seconds, and release the button until the system status LED starts blinking to restore factory settings and restart the switch.

Note

For details about LEDs on the front panel, see "LEDs."

1.2.2 Rear Panel

Figure 1-3 Rear Panel of the RG-ES208GC-V2

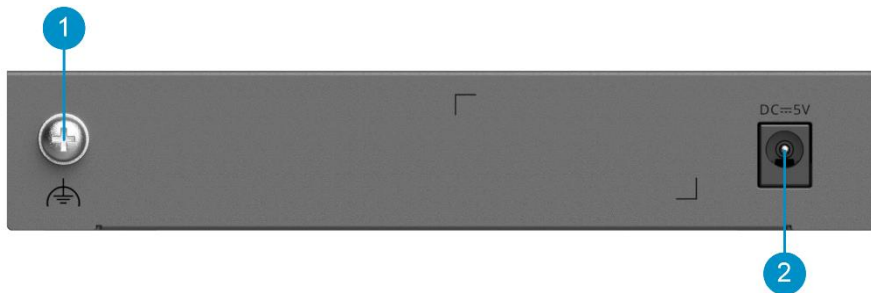

Table 1-2 Components on the Rear Panel

No.	Component	Description
1	Grounding stud	It is connected to a grounding wire.
2	DC power port	It is connected to a 5 V DC power source to supply power to the switch. The matching DC power connector has an outer diameter of 5.5 mm (0.22 in.), an inner diameter of 2.1 mm (0.08 in.), and a depth of 10 mm (0.39 in.).

1.2.3 LEDs

Figure 1-4 RG-ES208GC-V2 LEDs

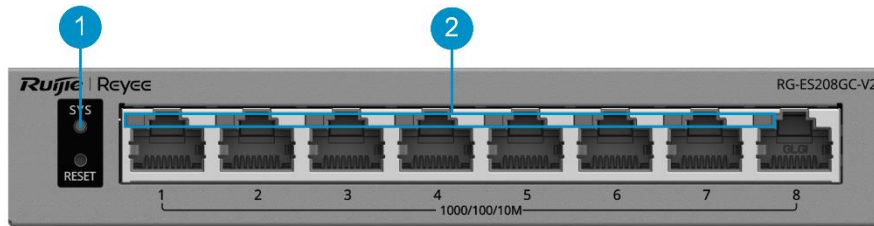

Table 1-3 LEDs

No.	Component	Silkscreen	Description
1	System status LED	SYS	<ul style="list-style-type: none"> ● Off: The switch is not powered on. ● Slow blinking green (0.5 Hz): The switch is operating normally but is not connected to Ruijie Cloud. ● Fast blinking green (10 Hz): The switch is upgrading or restarting, and is temporarily unavailable. ● Solid green: The switch is operating normally and connected to Ruijie Cloud. ● Slow blinking red (0.5 Hz): A loop occurs on the switch with loop guard enabled.
2	RJ45 port LED	-	<ul style="list-style-type: none"> ● Off: The port is not connected. ● Solid green: The port is operating at 1000 Mbps, 100 Mbps, or 10 Mbps, but is not receiving or sending data. ● Blinking green: The port is operating at 1000 Mbps, 100 Mbps, or 10 Mbps, and is receiving or sending data.

1.3 Cooling

The RG-ES208GC-V2 adopts fanless design and uses natural cooling. To ensure that the equipment works properly in the specified environment, a minimum clearance of 10 cm (3.94 in.) must be maintained around the equipment for air circulation and ventilation.

1.4 Technical Specifications

! Warning

- This equipment is not suitable for use in locations where children are likely to be present.
- Operation of this equipment in a residential environment could cause radio interference.

Table 1-4 Technical Specifications

Parameter Type	Parameter Name	RG-ES208GC-V2
System Specifications	Forwarding rate	11.90 Mpps
	Switching capacity	16 Gbps(bit/s)
	Flash memory	8MB
Port Specifications	Total number of RJ45 ports	8
	Number of 10/100/1000BASE-T ports	8
	Reset button	1
	LEDs	1 x system status LED 8 x Ethernet port LEDs
Power Supply and Consumption	Power supply	DC power adapter
	Power input	DC adapter: <ul style="list-style-type: none"> ● Rated input voltage: 100 V AC to 240 V AC, 50 Hz to 60 Hz ● Maximum input voltage: 90 V AC to 264 V AC, 47 Hz to 63 Hz ● Rated input current: 0.2 A Output : <ul style="list-style-type: none"> ● Rated output voltage: 5 V DC ● Maximum output current: 1 A
	Maximum power consumption	3.5 W
Dimensions and Weight	Product dimensions (W x D x H)	155mm x 78mm x 28mm (6.10 in. x 3.07 in. x 1.10 in.)
	Weight	0.27 kg (0.6 lbs) (without packaging materials)
	Shipping weight	0.46 kg (1.01 lbs)
	Casing	Metal
Interface	EEE	Yes
Environment and Reliability	Mounting options	Wall/Desk
	Hot swapping of cables	Hot swapping supported by the service port and power connector
	Fan	Fanless design

Parameter Type	Parameter Name	RG-ES208GC-V2
	Cooling	Natural cooling
	MTBF	200,000 hours
	ESD protection	Air discharge: 8 kV Contact discharge: 6 kV
	Surge protection	Service port: ± 6 kV for common mode Power connector: ± 4 kV for common mode and ± 2 kV for differential mode
	Operating temperature	0°C to 40°C (32°F to 104°F)
	Storage temperature	-40°C to +70°C (-40°F to +158°F)
	Operating humidity	10% RH to 90% RH (non-condensing)
	Storage humidity	5% RH to 95% RH (non-condensing)
	Altitude	-500 m to +5,000 m (-1,640.42 ft. to +16,404.20 ft.)
Certification and Regulatory Compliance	EMC	EN 55032 EN 61000-3-2 EN 61000-3-3 EN 55035 EN 300 386
	Safety compliance	EN 62368-1 IEC 62368-1
	Certification	CE,CB

2 Preparing for Installation

2.1 Package Contents

Table 2-1 Package Contents

No.	Item	Quantity
1	RG-ES208GC-V2 switch	1
2	User Manual	1
3	Warranty Card	1
4	Power adapter	1

Note

The package contents are subject to the purchase contract, and actual delivery may vary. Please check the items carefully against the package contents or purchase contract. If you have any questions, please contact the distributor.

2.2 Safety Guidelines

Note

- To avoid personal injury or equipment damage, review the safety guidelines in this chapter before you begin the installation.
 - The following safety guidelines may not include all the potentially hazardous situations.
-

2.2.1 General Precautions

- Never operate the equipment in a wet environment, and avoid any liquids inside it. Keep the chassis clean and dust-free.
- Keep the equipment away from heat sources.
- Keep the equipment away from walk areas.
- During installation and maintenance, do not wear loose clothing or ornament that may get caught in the chassis.
- Keep tools and accessories away from walk areas.

2.2.2 Chassis-Lifting Guidelines

- Avoid moving the equipment frequently.
- Turn off all power supplies and disconnect all cables before lifting or moving the equipment.

2.2.3 Electricity Safety

Warning

- Any deviation from standard or improper electrical operations can result in accidents such as fires or electric shocks, potentially causing severe or even fatal harm to both individuals and equipment.
 - Direct or indirect touch through a wet object on high-voltage and mains supply can bring a fatal danger.
-

- Always observe the local regulations and standards. Only qualified personnel should be allowed to operate the equipment.
- Carefully check the work area for potential hazards, including ungrounded power system, absent safety grounds, and damp floors.
- Locate the emergency power-off switch in the room before installation. In the case of an accident, cut off the power supply immediately.
- Never assume that power is connected to or disconnected from a circuit. Always check.
- Select the right leakage protector (also called "leakage current switch" or "leakage current breaker") for the power supply system. This equipment automatically disconnects the power supply in the event of leakage and the risk of electric shock. A leakage protector should meet the following requirements:
 - The rated leakage action current of each leakage protector must be at least twice the total maximum leakage current of all connected power supplies.

Example:

If a system has 16 identical power supplies, each with a maximum leakage current of 3.5 mA:

Total leakage current = $16 \times 3.5 \text{ mA} = 56 \text{ mA}$

For a 30 mA leakage protector:

Maximum number of power supplies per protector = $30 \text{ mA} / 2 / 3.5 \text{ mA} \approx 4$

Therefore, only four power supplies can be connected to one 30 mA leakage protector.

To support 16 power supplies, at least four 30 mA leakage protectors are required.

Always ensure:

Rated leakage operating current/2 > Total maximum leakage current of connected power supplies

- The rated leakage non-action current of a leakage protector should be 50% of the leakage action current. If the non-action current value is too small, the high sensitivity level can cause the circuit to break, leading to power cutoff and service interruption, even if the leakage current value is normal.

For example, if a leakage protector has a rated leakage action current of 30 mA, the rated leakage non-action current should be 15 mA. The leakage protector will not activate unless the leakage current exceeds 15 mA.

Caution

- To ensure personal safety, each leakage protector in the system must have a rated leakage action current equal to or below 30 mA, which is the recognized safety threshold for human body current. If the total leakage current of the system exceeds twice the 30 mA limit, the system must be equipped with two or more leakage protectors to maintain safety.
 - The leakage current values vary with equipment. For the leakage current value of each equipment model, see "Technical Specifications."
-

2.2.4 Preventing ESD Damage

- Ensure that the chassis is connected to earth ground.
- Keep the site as dust free as possible.
- Maintain appropriate humidity conditions.
- Before installing any pluggable modules, wear an anti-ESD wrist strap and make sure that it is properly grounded.
- Avoid contact between the printed circuit boards and clothing. The anti-ESD wrist strap only protects the printed circuit boards from ESD voltages on the body. ESD voltages on clothing can still cause damage.

2.3 Site Requirements

The equipment must be installed indoors for normal operation and prolonged service life.

The installation site must meet the following requirements.

2.3.1 Floor Loading

Assess the combined weight of the equipment and its accessories, such as chassis and power modules, and verify that the floor under the rack can bear the weight.

2.3.2 Airflow

The equipment adopts natural cooling. Reserve a sufficient clearance around the equipment to ensure proper ventilation.

2.3.3 Space

Do not install the equipment against a wall. Instead, maintain a minimum clearance of 10 cm (3.94 in.) around the equipment for heat dissipation and equipment maintenance.

2.3.4 Temperature and Humidity

To ensure the normal operation and a prolonged service life of the equipment, maintain an appropriate temperature and humidity in the installation environment.

Prolonged exposure to inappropriate temperature and humidity conditions can cause damage to the equipment.

- In an environment with high relative humidity, insulating materials are prone to poor insulation or even electricity leakage.
- In an environment with low relative humidity, insulating gaskets may shrink, resulting in screw loosening.
- In a dry environment, static electricity is more likely to occur, posing a risk to the internal circuits of equipment.
- A high temperature can accelerate the aging process of insulation materials, greatly reducing the availability of the equipment and severely affecting its service life.

2.3.5 Cleanliness

Dust poses a significant hazard to the equipment. Dust on the enclosure causes electrostatic adhesion, leading to poor contact of the metallic joints. Electrostatic adhesion is more likely to occur in an indoor environment with

relatively low humidity, not only affecting the service life of the equipment, but also causing communication faults. The following table lists the requirements for dust concentration and particle size in the equipment room.

Table 2-2 Requirements for Dust

Particle Diameter	Unit	Concentration
≥ 0.5 μm	Particles/m ³	≤ 3.5 × 10 ⁶
≥ 5 μm	Particles/m ³	≤ 3.5 × 10 ⁶

Apart from dust, there are also requirements on the salt, acid, and sulfide in the air of the equipment room. These harmful substances will accelerate metal corrosion and component aging. Therefore, the equipment room should be properly protected against harmful gases, such as sulfur dioxide, hydrogen sulfide, nitrogen dioxide, and chlorine gas. The following table lists the limits on harmful gases.

Table 2-3 Requirements for Gases

Gas	Average (mg/m ³)	Maximum (mg/m ³)
Sulfur dioxide (SO ₂)	0.3	1.0
Hydrogen sulfide (H ₂ S)	0.1	0.5
Nitrogen dioxide (NO ₂)	0.5	1.0
Chlorine gas (Cl ₂)	0.1	0.3

 **Note**

Average refers to the average value of harmful gases measured in a week. **Maximum** refers to the upper limit of harmful gases measured in a week for up to 30 minutes every day.

2.3.6 Grounding

A proper grounding system is crucial for ensuring stable and reliable operation, as well as preventing lightning strikes and interference. Carefully check the grounding conditions at the installation site according to the grounding requirements, and complete grounding properly based on the site situation.

- **Safety Grounding**

Ensure that the power distribution system is securely grounded if the equipment uses the AC power supply. Otherwise, electric shocks may occur when the insulation resistance between the power module and the chassis decreases.

 **Caution**

- The building should provide a protective ground connection to ensure that the equipment is connected to a protective ground.

- Verify that the AC socket is reliably connected to the protective grounding system of the building. If not, a protective grounding wire should be used to connect the protective grounding lug of the AC socket to the protective grounding system of the building.
-

- **Lightning Grounding**

The lightning protection system is an independent system composed of a lightning rod, a downlead conductor, and a connector connected to the grounding system. The grounding system is typically used for power reference grounding and safety grounding. Lightning grounding is required only for facilities, and is not required for the equipment.

- **EMC Grounding**

Electromagnetic compatibility (EMC) grounding includes shielded grounding, filter grounding, noise and interference suppression, and level reference.

2.3.7 Preventing Electromagnetic Interference

- Take interference prevention measures for the power supply system.
- Keep the equipment away from the grounding system or lightning protection grounding system of the power facility.
- Keep the equipment far away from high-frequency current equipment such as high-power radio transmitting stations and radar launchers.
- Take electromagnetic shielding measures when necessary.

2.3.8 Surge Protection

Although the equipment can guard against lightning strikes, strong lightning strikes may still damage the equipment. Take the following surge protection measures:

- Ensure that the grounding wire is in good contact with the ground.
- Ensure that the neutral point of the AC power socket is in good contact with the ground.
- Install a power arrester in front of the power input end to enhance surge protection for the power supply.

2.3.9 Installation Site

Regardless of whether the equipment is installed on a wall or a workbench, ensure that the following conditions are met:

- Maintain a proper clearance around the equipment for heat dissipation.
- Alternatively, place the equipment on a clean workbench. The installation of air conditioners is recommended in hot areas.

2.4 Tools

Table 2-4 Tools

Common Tools	Phillips screwdriver, cables, cage nuts, diagonal pliers, cable ties, and grounding wires
Dedicated Tools	Anti-ESD gloves, wire stripper, crimping pliers, RJ45 crimping pliers, and wire cutter
Meter	Multimeter

 **Note**

The equipment is delivered without a toolkit. Prepare the preceding tools by yourself.

3 Installing the Switch

⚠ Caution

Before installing the equipment, ensure that guidelines and requirements in Chapter 2 have been met.

3.1 Before You Begin

- The installation site provides sufficient space for heat dissipation.
- The installation site meets the temperature and humidity requirements.
- The power supply is available at the installation site, and its current meets the requirements.
- The Ethernet cables have been deployed at the installation site.
- Locate the emergency power-off switch in the room before installation. In the case of an accident, cut off the power supply immediately.

3.2 Installing the Switch

3.2.1 Wall Mount

i Note

- You need to prepare two M3 screws and two plastic expansion anchors for wall mounting.
 - For wall mounting, install the equipment only on concrete or other non-flammable surfaces.
-

The steps for wall mounting a switch are as follows:

- (1) Drill two holes at suitable positions on the wall with a spacing of 112.6 mm (4.43 in.). The hole diameter and depth depend on the specifications of the purchased plastic expansion anchors.
- (2) Insert two plastic expansion anchors into the drilled holes, and then screw two M3 screws into the plastic expansion anchors.

i Note

- Ensure that the distance between the inner side of the screw heads and the outer edge of the plastic expansion anchors is at least 2.5 mm (0.1 in.) to securely mount the equipment onto the screws.
 - The equipment appearance shown in the installation diagram is for reference only.
-

- (3) Mount the equipment on the two M3 screws, as shown in the following figure.

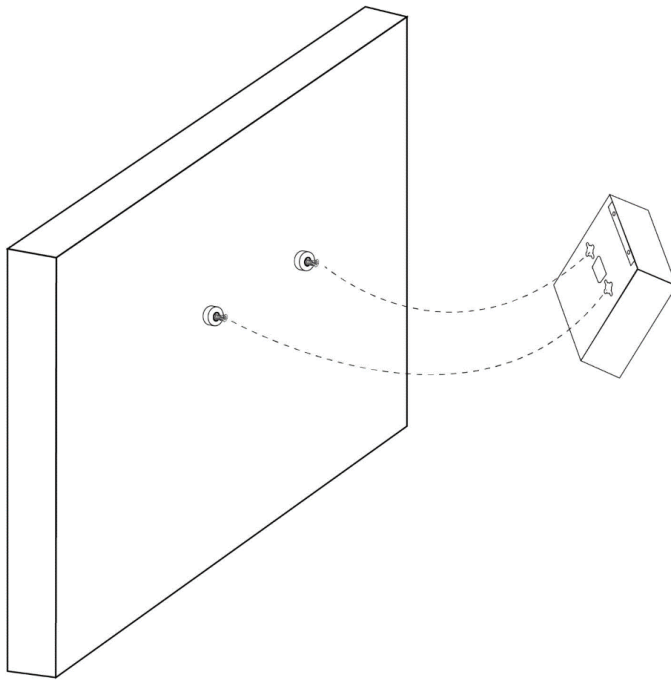
Figure 3-1 Mounting the Switch on a Wall

3.2.2 Workbench Mount

If wall mounting is not feasible, place the switch on a clean workbench and choose a location where it is unlikely to be touched, to ensure the safety and stability of the switch.

3.3 Grounding the Equipment

Note

- If the equipment is installed on a workbench, connect the grounding wire to the nearest grounding bar or grounding point based on the onsite situation.
 - The grounding wire is not delivered with the equipment and needs to be purchased by the customer.
-

The equipment has a grounding stud on the rear panel. You are advised to connect the system grounding wire to it before using the equipment.

- (1) Purchase a grounding wire and connect one end to the grounding stud at the rear of the equipment.
 - (2) Connect the other end of the grounding wire to the nearest grounding bar or grounding point.
-

Caution

- To avoid personal injury and equipment damage, connect the switch to earth ground properly. The grounding resistance between the chassis and the ground should be less than 1 ohm.
 - The O&M personnel should verify whether the AC socket is reliably connected to the protective ground of the building. If not, the O&M personnel should use a protective grounding wire to connect the protective grounding lug of the AC socket to the protective ground of the building.
 - The power socket should be installed near the equipment and easily accessible.
 - During the equipment installation, connect the grounding wire first and disconnect it last.
-

- The sectional area of a grounding wire should be determined according to the possible maximum current. Grounding wires with good conductors should be used.
 - Do not use bare wires.
-

3.4 Connecting Cables

Caution

All cables must be routed indoors. Take surge protection measures if they need to be routed outdoors.

After the switch is installed, connect the switch to other equipment according to the following steps:

- (1) Connect the power cord delivered with the switch to the power strip.
- (2) Connect the RJ45 connector of a twisted pair to an Ethernet port on the switch, and the other end to downlink equipment.

3.5 Bundling Cables

3.5.1 Precautions

- Bundle the power cord and other cables in an esthetically pleasing way.
- Do not bind twisted pairs too tightly, as this may compromise their service life and transmission performance.

3.5.2 Bundling Procedure

- (1) Bind the drooping part of the twisted pairs, and lead them to both sides of the chassis for convenience.
- (2) Bind the power cord closely along the bottom of the chassis, in a straight line wherever possible.

3.6 Verifying Installation

Caution

Please turn off the power to avoid personal injury and damage to components caused by incorrect connection.

- Verify that the grounding wire is connected.
- Verify that the cables including power cords are properly connected.
- Verify that cables connected to ports are routed indoors.
- Verify that the surge protection socket and Ethernet port arrester are installed, if outdoor cabling exists.
- Verify that there is a minimum clearance of 10 cm (3.94 in.) around the switch.

4 Commissioning

4.1 Power-on

- (1) Checklist Before Power-on
 - The switch is properly grounded.
 - The power cord is properly connected.
 - The power supply voltage meets the requirement of the switch.
- (2) Checklist After Power-on (Recommended)
 - The switch LEDs are in the normal state.
 - Service ports can forward data properly.

4.2 Logging In to the Management Interface

- (1) Connect a PC to an Ethernet port on the switch through an Ethernet cable.
- (2) Set the IP address of the PC to 10.44.77.XXX (Range: 1-254, excluding 200).

Figure 4-1 Changing the IP Address

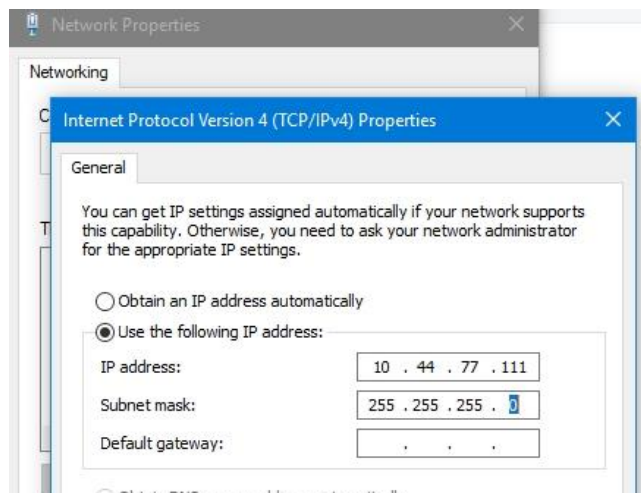

- (3) Open a browser, enter 10.44.77.200 in the address bar, and press Enter. On the login page, set a password and log in.
- (4) Perform equipment commissioning and configuration based on service requirements.

Note

For security purposes, you are advised to change the password regularly.

5 Troubleshooting

5.1 General Troubleshooting Flowchart

Note

You can determine whether each checking item in the process is normal based on the information provided in the previous chapters "Overview" and "Installing the Switch."

Figure 5-1 General Troubleshooting Flowchart

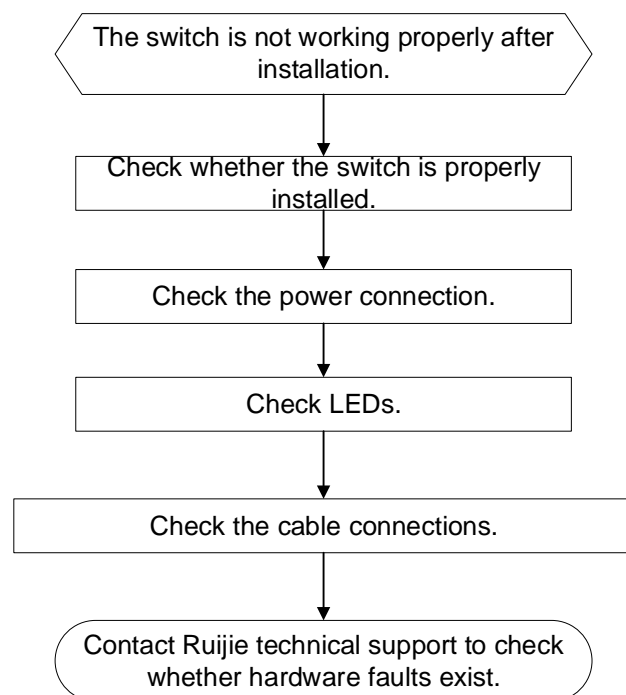

5.2 Common Faults

Table 5-1 Common Faults and Troubleshooting

Symptom	Possible Cause	Suggested Action
The system status LED is off after the switch is powered on.	No power is supplied to the switch or the power cord is loosely connected.	Check whether the power socket in the equipment room is normal and whether the power cord is loosely connected to the switch.
An RJ45 port is disconnected or a frame	The twisted pair is not connected properly.	Replace the twisted pair.

Symptom	Possible Cause	Suggested Action
sending/receiving error occurs.	The cable length exceeds 100 m (328.08 ft.).	Use an optical cable for data transmission or connect to an intermediate switch for relay.
	The port is specially configured and does not work in the same mode as that of the interconnected switch.	Check whether the port is configured to work in the same mode as that of the interconnected switch.
The login password cannot be retrieved.	The password is forgotten, and the equipment is not connected to the network or Ruijie Cloud.	Press and hold the Reset button to restore to factory settings.
	If the equipment is connected to Ruijie Cloud or a network, its login password is updated to the project or global management password.	If the equipment is connected to the cloud, log in using the project management password. If the equipment is connected to a network, log in using the global management password.

6 Appendix

6.1 Connectors and Media

6.1.1 100r100Or1000BASE-T Port

The 10/100/1000BASE-T port supports auto-negotiation for 10 Mbps, 100 Mbps, and 1000 Mbps connections and also supports auto MDI/MDIX Crossover.

Compliant with IEEE 802.3ab, a 1000BASE-T port connects to a 100-ohm Category 5 (CAT5) or Category 5 Enhanced (CAT5e) Unshielded Twisted Pair (UTP), or recommended Shielded Twisted Pair (STP) cable with a maximum distance of 100 m (328.08 ft.).

The 1000BASE-T port requires that all four pairs of wires be connected for data transmission. [Figure 6-1](#) shows twisted pair connections for the 1000BASE-T port.

Figure 6-1 Twisted Pair Connections for a 1000BASE-T Port

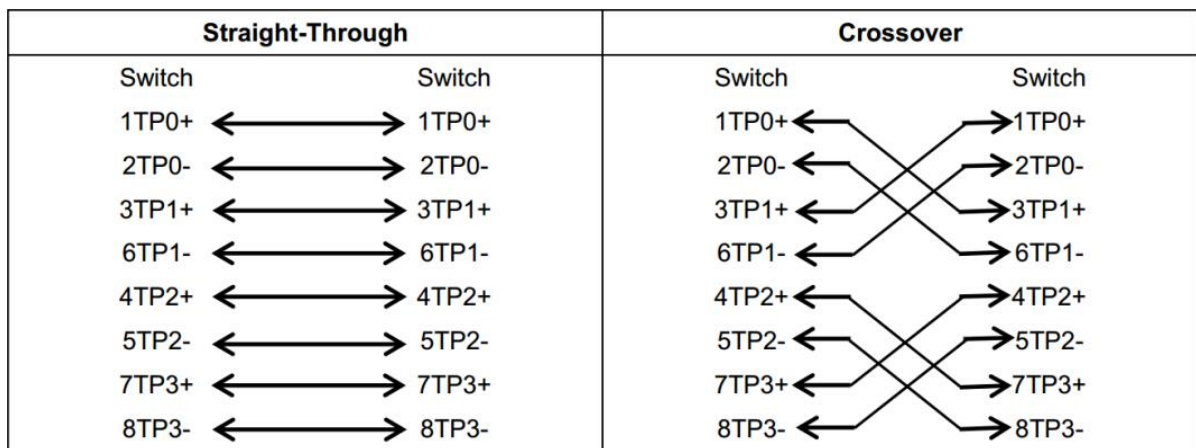

In addition to cables with the above-mentioned specifications, the 10/100BASE-T port can also be connected using 100-ohm CAT3, CAT4, and CAT5 cables at 10 Mbps or using 100-ohm CAT5 cables with a maximum distance of 100 m (328.08 ft.). The following table shows pin assignments for a 10/100BASE-T port.

Table 6-1 10/100BASE-T Pin Assignment

Pin	Socket	Plug
1	Input Receive Data+	Output Transmit Data+
2	Input Receive Data-	Output Transmit Data-
3	Output Transmit Data+	Input Receive Data+
6	Output Transmit Data-	Input Receive Data-
4, 5, 7, and 8	Not Used	Not Used

The following table shows wiring of straight-through and crossover cables for a 10/100BASE-T port.

Figure 6-2 Twisted Pair Connections for a 10/100BASE-T Port

Straight-Through		Crossover	
Switch	Adapter	Switch	Switch
1 IRD+	1 OTD+	1 IRD+	1 OTD+
2 IRD-	2 OTD-	2 IRD-	2 OTD-
3 OTD+	3 IRD+	3 OTD+	3 IRD+
6 OTD-	6 IRD-	6 OTD-	6 IRD+

6.2 Lightning Protection

6.2.1 Installing the AC Power Arrester (Power Strip with Surge Protection)

When an alternating current (AC) power cord is introduced from outdoors and directly connected to the AC power port of the switch, the power port must be connected to an external power arrester to safeguard the switch against lightning strikes. The power arrester can be fixed on the rack, workbench, or wall in the equipment room by using cable ties and screws. AC power enters the power arrester before entering the switch.

Figure 6-3 Power Arrester

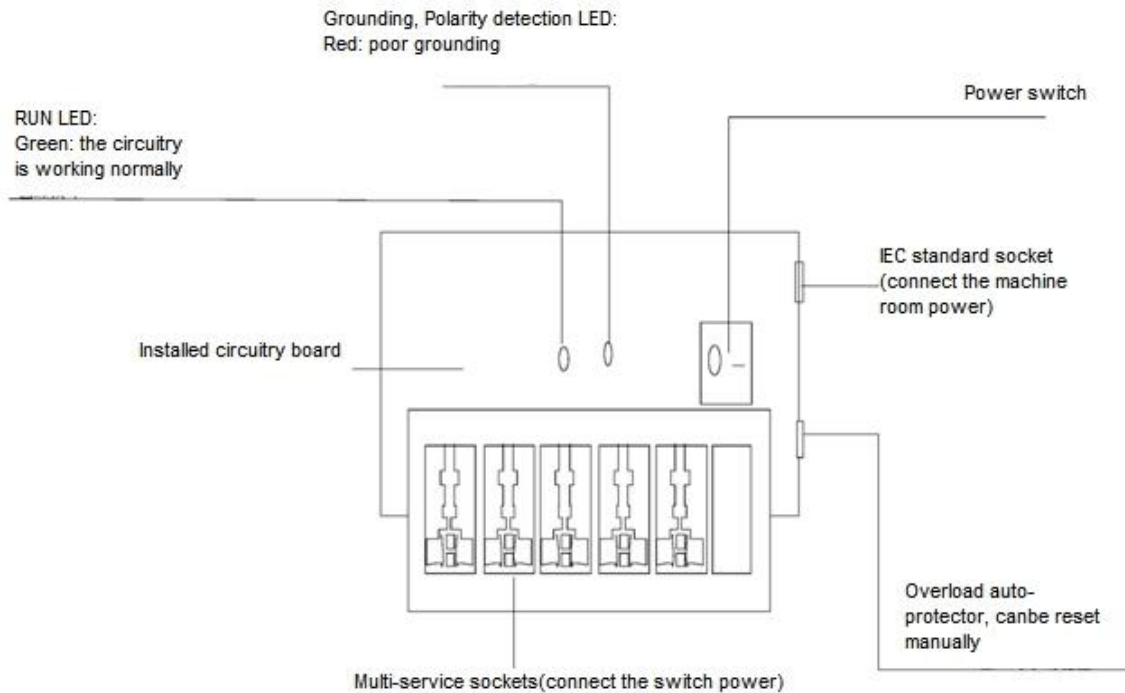

⚠ Caution

The power arrester is not delivered with the equipment. Please purchase it based on actual requirements.

Precautions during the installation:

- Make sure that the PE terminal of the power arrester is well grounded.
- After the AC power plug of the switch is connected to the socket of the power arrester, the lightning protection function is implemented only if the running status LED is green and the alarm LED is off.
- If the alarm LED on the power arrester is red, check whether it is caused by a poor grounding connection or by the reversed connection of the neutral and live wires. The detection method is as follows: Use a multimeter to measure the polarity of the power arrester when the alarm LED is red. If the neutral wire is on the left and the live wire is on the right (facing the socket), the PE terminal of the power arrester is not grounded. If not, the polarity of the power arrester should be reversed. In this case, open the power arrester and reverse its polarity. If the alarm LED is still red, the PE terminal of the power arrester is not grounded.

6.2.2 Installing the Ethernet Port Arrester

Please connect an Ethernet port arrester to the switch to prevent the damage by lightning strikes before connecting an outdoor Ethernet cable to the switch.

- Tools: Phillips screwdriver or flat-blade screwdriver, multimeter, and diagonal pliers
- Installation steps
 - a Tear one side of the protective paper for the double-sided adhesive tape and paste the tape to the enclosure of the Ethernet port arrester. Tear the other side of the protective paper for the double-sided adhesive tape and paste the Ethernet port arrester to the switch enclosure. The paste position for the Ethernet port arrester should be as close to the grounding lug of the switch as possible.
 - b Based on the distance between the grounding lug of the switch and the Ethernet port arrester, cut the grounding cable of the Ethernet port arrester and firmly tighten the grounding cable to the grounding lug of the switch.
 - c Use a multimeter to check whether the grounding cable for the arrester is in good contact with the grounding lug and the enclosure of the switch.
 - d Connect the Ethernet port arrester by using an adapter cable (note that the external Ethernet cable is connected to the IN end, while the adapter cable connected to the switch is connected to the OUT end) and check whether the module LED is normal.
 - e Use a nylon cable tie to bind the cables.

Figure 6-4 Installing an Ethernet Port Arrester

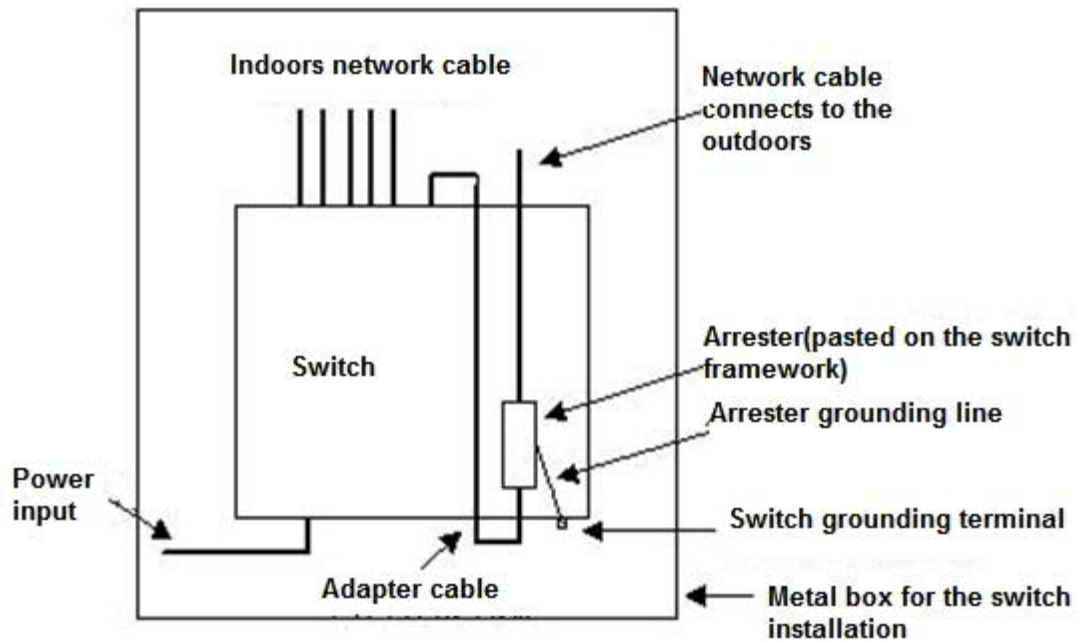

⚠ Caution

- The Ethernet port arrester is only for a 10 Mbps, 100 Mbps, or 1000 Mbps RJ45 port.
- The Ethernet port arrester is not delivered with the equipment. Please purchase it based on actual requirements. The user manual for Ethernet port arresters contains technical parameters and maintenance and installation instructions. Carefully read this manual during installation.

Pay attention to the following situations during the actual installation to avoid influencing the performance of an Ethernet port arrester:

- The arrester is incorrectly connected to the cables. Connect the external Ethernet cable to the IN end and connect the Ethernet port of the switch to the OUT end.
- The Ethernet port arrester is incorrectly grounded. The grounding cable of the arrester should be as short as possible to ensure that it is in good contact with the grounding lug of the switch. Use a multimeter to confirm the contact condition after grounding.
- Not all Ethernet ports are installed with Ethernet port arresters. If outdoor Ethernet cables connect the switch ports to the peer equipment, Ethernet port arresters need to be installed on all the ports for the purpose of lightning protection.

6.3 Recommended Cabling

When the switch is installed in a standard 19-inch cabinet, secure the cables around the cable management brackets. Top cabling or bottom cabling is adopted according to the actual situation in the equipment room. All adapted connectors should be placed at the bottom of the rack in an orderly manner instead of outside the rack that is easy to touch. Power cords are routed beside the rack. Top cabling or bottom cabling is adopted according to the actual situation in the equipment room, such as the positions of the DC power distribution box, AC socket, or lightning protection box.

6.3.1 Requirement for the Minimum Bend Radius of Cables

- The bend radius of a fixed power cord, Ethernet cable, and flat cable should be over five times greater than their respective external diameters. The bend radius of these cables that are often bent or plugged should be over seven times greater than their respective external diameters.
- The bend radius of a fixed common coaxial cable should be over seven times greater than its external diameter. The bend radius of these cables that are often bent or plugged should be over 10 times greater than their respective external diameters.
- The minimum bend radius of a high-speed cable, such as an SFP+ cable, should be 5 times the overall diameter of the cable. If the cable is constantly bent, plugged or unplugged, the bend radius should be 10 times the overall diameter.
- The minimum bend radius of optical cables should meet the following requirements.
 - The diameter of the optical cable tray should be no less than 25 times greater than that of the optical cable.
 - When an optical cable is moved, its bend radius should be no less than 20 times greater than its diameter.
 - During cabling of an optical cable, its bend radius should be no less than 10 times greater than its diameter.

6.3.2 Precautions for Cable Bundling

- Before cables are bundled, mark labels and stick the labels to cables wherever appropriate.
- Cables should be neatly and properly bundled in the rack without twisting or bending, as shown in [Figure 6-5](#).

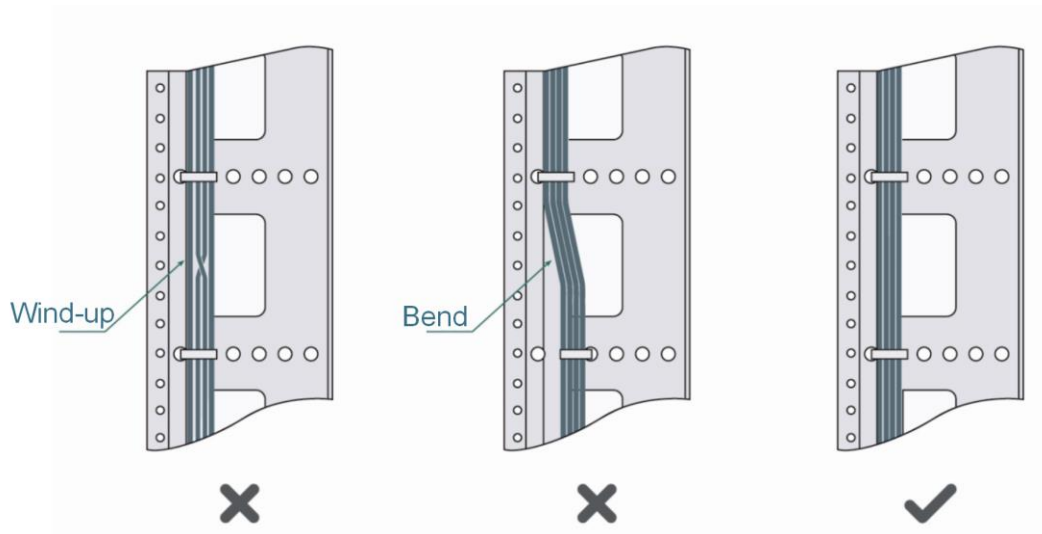
Figure 6-5 Bundling Cables (1)

- Cables of different types (such as power cords, signal cables, and grounding wires) should be separated in cabling and bundling. Mixed bundling is not allowed. When they are close to each other, you are advised to adopt crossover cabling. In the case of parallel cabling, maintain a minimum distance of 30 mm (1.18 in.) between power cords and signal cables.
- The cable management brackets and cabling troughs inside and outside the rack should be smooth without sharp corners.
- The metal holes traversed by cables should have a smooth and fully rounded surface or an insulated lining.
- Use cable ties to bundle cables properly. Please do not connect two or more cable ties to bundle cables.
- After bundling up cables with cable ties, cut off the remaining part. The cut should be smooth and trim without sharp corners, as shown in [Figure 6-6](#).

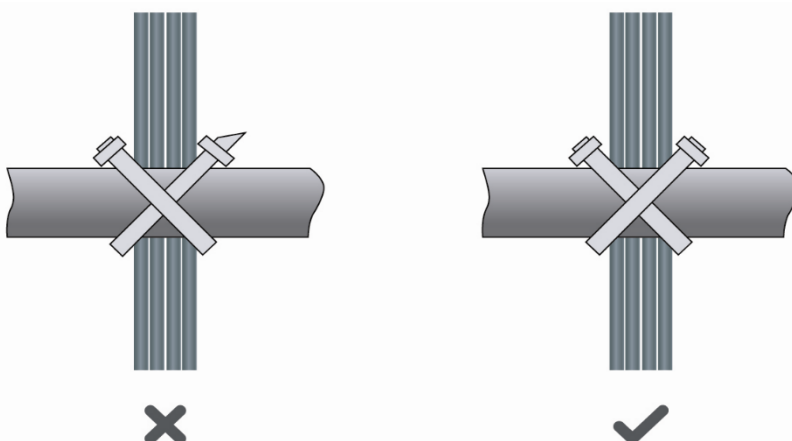
Figure 6-6 Bundling Cables (2)

- When cables need to be bent, bundle them first but do not tie cables within the bend. Otherwise, stress may be generated on the cables and cause the wires inside to break, as shown in [Figure 6-7](#).

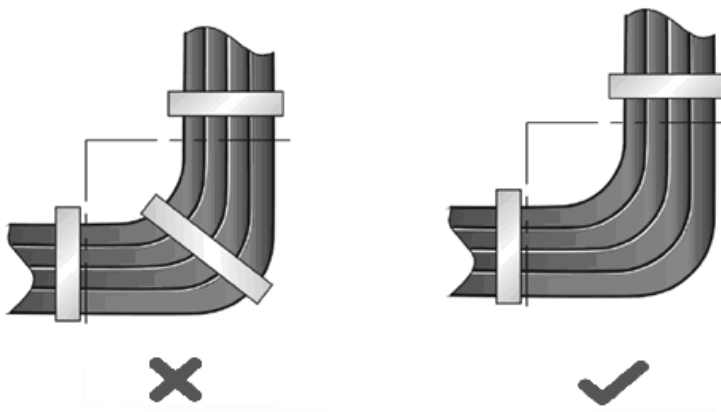
Figure 6-7 Bundling Cables (3)

- Cables not to be assembled or the remaining parts of cables should be folded and placed in a proper position of the rack or cable management trough. The proper position refers to a position that does not affect the equipment running or damage the equipment or cables.
- Power cords must not be bundled on the guide rails of moving parts.
- The power cords connecting moving parts such as door grounding wires should be reserved with some excess after being assembled to avoid suffering tension or stress. When a moving part reaches the installation position, the remaining cable part should not touch heat sources, sharp corners, or sharp edges. If heat sources must be touched, high-temperature cables should be used.
- When using screw threads to secure a cable lug, ensure that the bolt or screw is properly tightened and take measures to prevent it from loosening, as shown in [Figure 6-8](#).

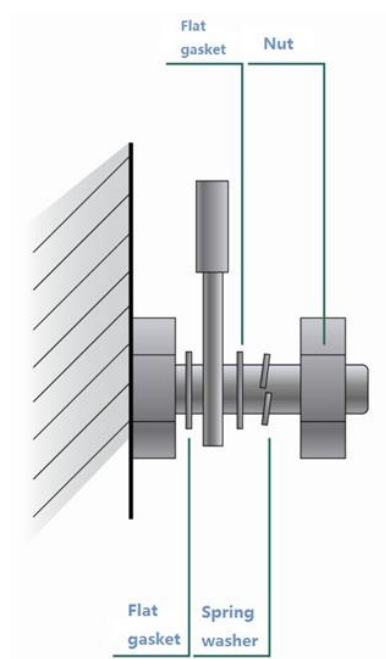
Figure 6-8 Fastening Cables

- Hard power cords should be secured near the cable termination area to prevent stress on the cable

termination area and cables.

- Do not use tapping screws to secure cable lugs.
- Power cords of the same type and in the same cabling direction should be bundled up into cable bunches, with cables in cable bunches clean and straight.
- Bundle cables by using cable ties according to the following table.

Cable Bunch Diameter	Bundling Spacing
10 mm (0.39 in.)	80–150 mm (3.15–5.91 in.)
10–30 mm (0.39–1.18 in.)	150–200 mm (5.91–7.87 in.)
30 mm (1.18 in.)	200–300 mm (7.87–11.81 in.)

- Do not tie cables or bundles in a knot.
- For wiring terminal blocks (such as circuit breakers) with cord end terminals, the metal part of the cord end terminal should not be exposed outside the terminal block when assembled.

6.4 Site Selection

- The equipment room should be at least 5 km (3.11 miles) away from heavy pollution sources, such as smelters, coal mines, and thermal power plants. The equipment room should be at least 3.7 km (2.30 miles) away from medium pollution sources, such as the chemical factory, rubber factory, and electroplating factory. The equipment room should be at least 2 km (1.24 miles) away from light pollution sources, such as the food factory and leather plant. If the pollution source is unavoidable, the equipment room should be located on the windward side of the pollution source perennially with advanced protection.
- The equipment room should be at least 3.7 km (2.30 miles) away from the sea or salt lake. Otherwise, the equipment room must be sealed, with an air conditioner installed for temperature control. Saline soil cannot be used for construction. Otherwise, you should select equipment with advanced protection against severe environments.
- Do not build the equipment room in the proximity of livestock farms. Otherwise, the equipment room should be located on the windward side of the pollution source perennially. The previous livestock house or fertilizer warehouse cannot be used as the equipment room.
- The equipment room should be firm enough to withstand severe weather conditions such as windstorms, heavy rain, and dense dust. If the dust is unavoidable, keep the door and window away from the pollution source.
- The equipment falls into Class A. Therefore, the equipment room should be located away from the residential area. Otherwise, the equipment room should meet construction specifications to avoid noise and radio interference.
- Make sure the air vent of the equipment room is away from the sewage pipe, septic tank, and sewage treatment tank. Keep the equipment room under positive pressure to prevent corrosive gas from entering the equipment room to corrode components and circuit boards.
- Keep the equipment room away from industrial boilers and heating boilers.
- The equipment room should be on the second floor or higher. Otherwise, the equipment room floor should

be 600 mm (23.62 in.) higher than the highest flood level ever recorded.

- Make sure no cracks or holes exist in the wall and floor. If there are cable entries in the wall or window, take proper sealing measures. Ensure that the wall is flat, wear-resistant, and dust-free, meeting standards for flame resistance, soundproofing, heat absorption, dust reduction, and electromagnetic shielding.
- Keep the door and the window closed to make the equipment room sealed.
- You are advised to use the steel door for soundproofing.
- Do not use sulfur-containing materials.
- Keep the air conditioner from blowing wind straight toward the equipment or blowing water drops from the window or air vent toward the equipment.

Contents

1 Overview	4
1.1 About the RG-ES211GS-LP	4
1.2 Equipment Appearance	4
1.2.1 Front Panel.....	4
1.2.2 Rear Panel	5
1.2.3 LEDs	6
1.3 Cooling.....	7
1.4 Technical Specifications	7
2 Preparing for Installation	10
2.1 Package Contents.....	10
2.2 Safety Guidelines.....	10
2.2.1 General Precautions	10
2.2.2 Chassis-Lifting Guidelines	10
2.2.3 Electricity Safety	11
2.2.4 Preventing ESD Damage.....	12
2.2.5 Laser Safety	12
2.3 Site Requirements	12
2.3.1 Floor Loading	12
2.3.2 Airflow.....	13
2.3.3 Space	13
2.3.4 Temperature and Humidity.....	13
2.3.5 Cleanliness.....	13

2.3.6 Grounding	14
2.3.7 Preventing Electromagnetic Interference	14
2.3.8 Surge Protection	15
2.3.9 Installation Site.....	15
2.4 Tools	15
3 Installing the Switch	16
3.1 Before You Begin.....	16
3.2 Installing the Switch	16
3.2.1 Wall Mount	16
3.2.2 Workbench Mount.....	17
3.3 Grounding the Equipment.....	17
3.4 Connecting Cables.....	18
3.5 Bundling Cables.....	18
3.5.1 Precautions	18
3.5.2 Bundling Procedure	18
3.6 Verifying Installation.....	18
4 Commissioning.....	20
4.1 Power-on.....	20
4.2 Logging In to the Management Interface.....	20
5 Troubleshooting.....	21
5.1 General Troubleshooting Flowchart	21
5.2 Common Faults.....	21
6 Appendix.....	23
6.1 Connectors and Media.....	23

6.1.1 10Or100Or1000BASE-T Port	23
6.1.2 Optical Cable Connection	24
6.2 SFP Transceivers	24
6.3 Lightning Protection	26
6.3.1 Installing the AC Power Arrester (Power Strip with Surge Protection)	26
6.3.2 Installing the Ethernet Port Arrester	27
6.4 Recommended Cabling	29
6.4.1 Requirement for the Minimum Bend Radius of Cables	29
6.4.2 Precautions for Cable Bundling	29
6.5 Site Selection	32

1 Overview

1.1 About the RG-ES211GS-LP

The RG-ES211GS-LP Ethernet switch provides ten 10/100/1000BASE-T ports, one 1GE SFP port, one Reset button, and several LEDs on the front panel, along with a 54 V DC power port, a DIP switch, and a grounding stud on the rear panel. Ports 1–8 support Power over Ethernet (PoE) Out.

Figure1-1 RG-ES211GS-LP Appearance



i Note

- 1GE SFP port: Supports only 1GE SFP optical transceivers (not compatible with 100 Mbps optical cables).
- 10/100/1000BASE-T port: Supports auto-negotiation at 10 Mbps, 100 Mbps, and 1000 Mbps.

1.2 Equipment Appearance

1.2.1 Front Panel

Figure1-2 Front Panel of the RG-ES211GS-LP

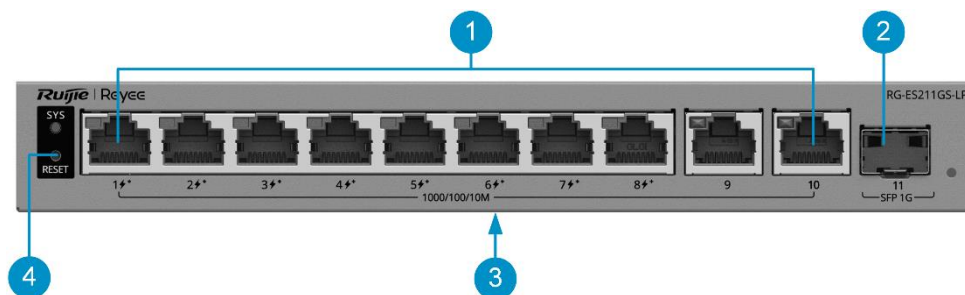

Note

⚡ indicates the PoE+ ports, which are compliant with IEEE 802.3at, and backward compatible with IEEE 802.3af.

Table1-1 Components on the Front Panel

No.	Component	Silkscreen	Description
1	RJ45 port	1–10	10/100/1000BASE-T ports, with ports 1–8 supporting PoE Out.
2	SFP port	11	1GE SFP port, supporting 1GE SFP transceiver (hot-swappable)
3	Nameplate	-	It is located at the bottom of the switch.
4	Reset button	RESET	<ul style="list-style-type: none"> Press and hold the button for less than 2 seconds. The switch is reset. Press and hold the button for 2–5 seconds. No action is performed. Press and hold the button for more than 5 seconds, and release the button until the system status LED starts blinking to restore factory settings and restart the switch.

Note

For details about LEDs on the front panel, see "LEDs."

1.2.2 Rear Panel

Figure1-3 Rear Panel of the RG-ES211GS-LP

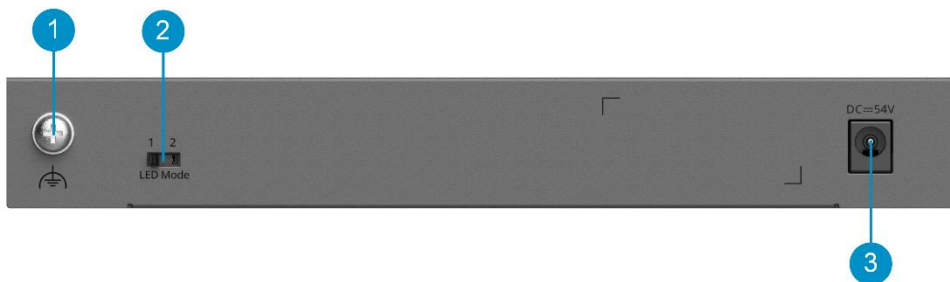

Table1-2 Components on the Rear Panel

No.	Component	Description
1	Grounding stud	It is connected to a grounding wire.
2	DIP switch	Toggle the DIP switch to change the LED modes of ports 1–8. <ul style="list-style-type: none"> LED mode 1 (switching mode): When the DIP switch is toggled to the left, the port LEDs display the data transmission status. LED mode 2 (PoE mode): When the switch is toggled to the right, the

		port LEDs display the PoE status.
3	DC power port	It is connected to a 54 V DC power source to supply power to the switch. The matching DC power connector has an outer diameter of 5.5 mm (0.22 in.), an inner diameter of 2.1 mm (0.08 in.), and a depth of 10 mm (0.39 in.).

1.2.3 LEDs

Figure1-4 RG-ES211GS-LP LEDs

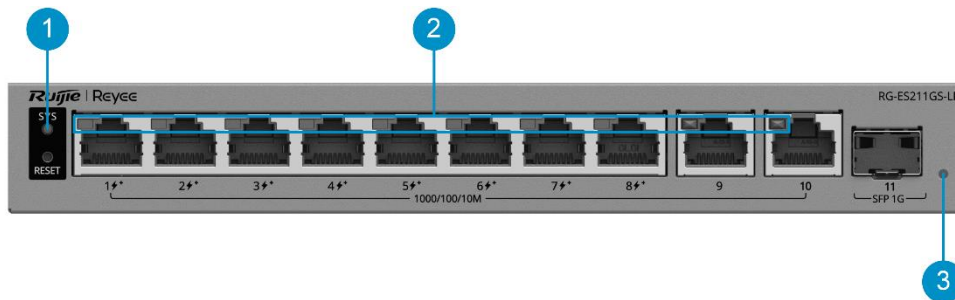

Table1-3 LEDs

No.	Component	Silkscreen	Description
1	System status LED	SYS	<ul style="list-style-type: none"> ● Off: The switch is not powered on. ● Slow blinking green (0.5 Hz): The switch is operating normally but is not connected to Ruijie Cloud. ● Fast blinking green (10 Hz): The switch is upgrading or restarting, and is temporarily unavailable. ● Solid green: The switch is operating normally and connected to Ruijie Cloud. ● Slow blinking yellow (0.5 Hz): The PoE power is insufficient. ● Slow blinking red (0.5 Hz): A loop occurs on the switch with loop guard enabled.
2	RJ45 port LED	-	<p>LEDs of ports 1–8 support switching mode and PoE mode, which can be switched by toggling the DIP switch on the rear of the switch. LEDs of ports 9 and 10 support only switching mode.</p> <ul style="list-style-type: none"> ● Switching mode: <ul style="list-style-type: none"> ○ Off: The port is not connected. ○ Solid green: The port is operating at 1000 Mbps, 100 Mbps, or 10 Mbps, but is not receiving or sending data. ○ Blinking green: The port is operating at 1000 Mbps, 100 Mbps, or 10 Mbps, and is receiving or sending data. ● PoE mode: <ul style="list-style-type: none"> ○ Off: PoE is disabled on the port. ○ Solid green: PoE is enabled on the port. ○ Blinking green: PoE overload occurs on the port.

No.	Component	Silkscreen	Description
3	SFP port LED	-	<ul style="list-style-type: none"> ● Off: The port is not connected. ● Solid green: The port is operating at 1000 Mbps, but is not receiving or sending data. ● Blinking green: The port is operating at 1000 Mbps, and is receiving or sending data.

1.3 Cooling

The RG-ES211GS-LP adopts fanless design and uses natural cooling. To ensure that the equipment works properly in the specified environment, a minimum clearance of 10 cm (3.94 in.) must be maintained around the equipment for air circulation and ventilation.

1.4 Technical Specifications

Warning

- This equipment is not suitable for use in locations where children are likely to be present.
- Operation of this equipment in a residential environment could cause radio interference.

Table1-4 Technical Specifications

Parameter Type	Parameter Name	RG-ES211GS-LP
System Specifications	Forwarding rate	16.36 Mpps
	Switching capacity	22 Gbps(bit/s)
	Flash memory	8 MB
Port Specifications	Total number of optical ports	1
	Total number of RJ45 ports	10
	Number of 10/100/1000BASE-T ports	10
	Number of 1GE SFP ports	1
	Reset button	1
	LEDs	1 x system status LED 10 x Ethernet port LEDs 1 x SFP port LED

Parameter Type	Parameter Name	RG-ES211GS-LP
	DIP switch	<p>LED mode switch toggled to left (Mode 1): The port LED status indicates the status of traffic transmission. Solid green means that the port is link up, while blinking green means that the port is transmitting and receiving data.</p> <p>LED mode switch toggled to right (Mode 2): The port LED status indicates the PoE status. Solid green means that the port is supplying power, while blinking green means that the port is in power overload state.</p>
Power Supply and Consumption	Power supply	DC power adapter
	Power input	DC adapter: <ul style="list-style-type: none"> ● Rated input voltage: 100 V AC to 240 V AC, 50 Hz to 60 Hz ● Maximum input voltage: 90 V AC to 264 V AC, 47 Hz to 63 Hz ● Rated input current: 1.5 A Output : <ul style="list-style-type: none"> ● Rated output voltage: 54 V DC ● Maximum output current: 1.48 A
	Maximum power consumption	8 W (with no PoE load) 78 W (with full PoE load)
	Number of PoE Out ports	8
	Number of PoE/PoE+ Out ports	8
	PoE Out standard	PoE/PoE+ (IEEE 802.3af/at)
	PoE power pins	1–2 (+), 3–6 (-)
	PoE budget per port	30 W
	PoE budget	70 W
Dimensions and Weight	Product dimensions (W x D x H)	205mm x 105mm x 28mm (8.07 in. x 4.13 in. x 1.10 in.)
	Weight	0.45 kg (0.99 lbs) (without packaging materials)
	Shipping weight	1 kg (2.2 lbs)
	Casing	Metal

Parameter Type	Parameter Name	RG-ES211GS-LP
Interface	EEE	Yes
Environment and Reliability	Mounting options	Wall/Desk
	Hot swapping of cables	Hot swapping supported by the service port and power connector
	Fan	Fanless design
	Cooling	Natural cooling
	MTBF	200,000 hours
	ESD protection	Air discharge: 8 kV Contact discharge: 6 kV
	Surge protection	Service port: ± 6 kV for common mode Power connector: ± 4 kV for common mode and ± 2 kV for differential mode
	Operating temperature	0°C to 40°C (32°F to 104°F)
	Storage temperature	-40°C to +70°C (-40°F to +158°F)
	Operating humidity	10% RH to 90% RH (non-condensing)
	Storage humidity	5% RH to 95% RH (non-condensing)
	Altitude	-500 m to +5,000 m (-1,640.42 ft. to +16,404.20 ft.)
Certification and Regulatory Compliance	EMC	EN 55032 EN 61000-3-2 EN 61000-3-3 EN 55035 EN 300 386
	Safety compliance	EN 62368-1 IEC 62368-1
	Certification	CE,CB

2 Preparing for Installation

2.1 Package Contents

Table2-1 Package Contents

No.	Item	Quantity
1	RG-ES211GS-LP switch	1
2	User Manual	1
3	Warranty Card	1
4	Power adapter	1
5	Power cord	1

Note

The package contents are subject to the purchase contract, and actual delivery may vary. Please check the items carefully against the package contents or purchase contract. If you have any questions, please contact the distributor.

2.2 Safety Guidelines

Note

- To avoid personal injury or equipment damage, review the safety guidelines in this chapter before you begin the installation.
 - The following safety guidelines may not include all the potentially hazardous situations.
-

2.2.1 General Precautions

- Never operate the equipment in a wet environment, and avoid any liquids inside it. Keep the chassis clean and dust-free.
- Keep the equipment away from heat sources.
- Keep the equipment away from walk areas.
- During installation and maintenance, do not wear loose clothing or ornament that may get caught in the chassis.
- Keep tools and accessories away from walk areas.

2.2.2 Chassis-Lifting Guidelines

- Avoid moving the equipment frequently.
- Turn off all power supplies and disconnect all cables before lifting or moving the equipment.

2.2.3 Electricity Safety

Warning

- Any deviation from standard or improper electrical operations can result in accidents such as fires or electric shocks, potentially causing severe or even fatal harm to both individuals and equipment.
 - Direct or indirect touch through a wet object on high-voltage and mains supply can bring a fatal danger.
-

- Always observe the local regulations and standards. Only qualified personnel should be allowed to operate the equipment.
- Carefully check the work area for potential hazards, including ungrounded power system, absent safety grounds, and damp floors.
- Locate the emergency power-off switch in the room before installation. In the case of an accident, cut off the power supply immediately.
- Never assume that power is connected to or disconnected from a circuit. Always check.
- Select the right leakage protector (also called "leakage current switch" or "leakage current breaker") for the power supply system. This equipment automatically disconnects the power supply in the event of leakage and the risk of electric shock. A leakage protector should meet the following requirements:
 - The rated leakage action current of each leakage protector must be at least twice the total maximum leakage current of all connected power supplies.

Example:

If a system has 16 identical power supplies, each with a maximum leakage current of 3.5 mA:

Total leakage current = $16 \times 3.5 \text{ mA} = 56 \text{ mA}$

For a 30 mA leakage protector:

Maximum number of power supplies per protector = $30 \text{ mA} / 2 / 3.5 \text{ mA} \approx 4$

Therefore, only four power supplies can be connected to one 30 mA leakage protector.

To support 16 power supplies, at least four 30 mA leakage protectors are required.

Always ensure:

Rated leakage operating current/2 > Total maximum leakage current of connected power supplies

- The rated leakage non-action current of a leakage protector should be 50% of the leakage action current. If the non-action current value is too small, the high sensitivity level can cause the circuit to break, leading to power cutoff and service interruption, even if the leakage current value is normal.

For example, if a leakage protector has a rated leakage action current of 30 mA, the rated leakage non-action current should be 15 mA. The leakage protector will not activate unless the leakage current exceeds 15 mA.

Caution

- To ensure personal safety, each leakage protector in the system must have a rated leakage action current equal to or below 30 mA, which is the recognized safety threshold for human body current. If the total leakage current of the system exceeds twice the 30 mA limit, the system must be equipped with two or more leakage protectors to maintain safety.
 - The leakage current values vary with equipment. For the leakage current value of each equipment model, see "Technical Specifications."
-

2.2.4 Preventing ESD Damage

- Ensure that the chassis is connected to earth ground.
- Keep the site as dust free as possible.
- Maintain appropriate humidity conditions.
- Before installing any pluggable modules, wear an anti-ESD wrist strap and make sure that it is properly grounded.
- Avoid contact between the printed circuit boards and clothing. The anti-ESD wrist strap only protects the printed circuit boards from ESD voltages on the body. ESD voltages on clothing can still cause damage.

2.2.5 Laser Safety

The equipment supports various types of optical transceivers, which are Class 1 laser products.

Precautions:

- When an optical transceiver is working, ensure that its port is connected to an optical cable or covered by a dust cap to keep out dust and prevent it from burning your eyes.
- Do not stare into an optical port.

Figure2-1 Laser Product ID



Caution

Do not approach or stare into an optical port under any circumstances. This may cause permanent damage to your eyes.

2.3 Site Requirements

The equipment must be installed indoors for normal operation and prolonged service life.

The installation site must meet the following requirements.

2.3.1 Floor Loading

Assess the combined weight of the equipment and its accessories, such as chassis and power modules, and verify that the floor under the rack can bear the weight.

2.3.2 Airflow

The equipment adopts natural cooling. Reserve a sufficient clearance around the equipment to ensure proper ventilation.

2.3.3 Space

Do not install the equipment against a wall. Instead, maintain a minimum clearance of 10 cm (3.94 in.) around the equipment for heat dissipation and equipment maintenance.

2.3.4 Temperature and Humidity

To ensure the normal operation and a prolonged service life of the equipment, maintain an appropriate temperature and humidity in the installation environment.

Prolonged exposure to inappropriate temperature and humidity conditions can cause damage to the equipment.

- In an environment with high relative humidity, insulating materials are prone to poor insulation or even electricity leakage.
- In an environment with low relative humidity, insulating gaskets may shrink, resulting in screw loosening.
- In a dry environment, static electricity is more likely to occur, posing a risk to the internal circuits of equipment.
- A high temperature can accelerate the aging process of insulation materials, greatly reducing the availability of the equipment and severely affecting its service life.

2.3.5 Cleanliness

Dust poses a significant hazard to the equipment. Dust on the enclosure causes electrostatic adhesion, leading to poor contact of the metallic joints. Electrostatic adhesion is more likely to occur in an indoor environment with relatively low humidity, not only affecting the service life of the equipment, but also causing communication faults. The following table lists the requirements for dust concentration and particle size in the equipment room.

Table2-2 Requirements for Dust

Particle Diameter	Unit	Concentration
≥ 0.5 μm	Particles/m ³	≤ 3.5 × 10 ⁶
≥ 5 μm	Particles/m ³	≤ 3.5 × 10 ⁶

Apart from dust, there are also requirements on the salt, acid, and sulfide in the air of the equipment room. These harmful substances will accelerate metal corrosion and component aging. Therefore, the equipment room should be properly protected against harmful gases, such as sulfur dioxide, hydrogen sulfide, nitrogen dioxide, and chlorine gas. The following table lists the limits on harmful gases.

Table2-3 Requirements for Gases

Gas	Average (mg/m ³)	Maximum (mg/m ³)
Sulfur dioxide (SO ₂)	0.3	1.0
Hydrogen sulfide (H ₂ S)	0.1	0.5

Gas	Average (mg/m ³)	Maximum (mg/m ³)
Nitrogen dioxide (NO ₂)	0.5	1.0
Chlorine gas (Cl ₂)	0.1	0.3

Note

Average refers to the average value of harmful gases measured in a week. **Maximum** refers to the upper limit of harmful gases measured in a week for up to 30 minutes every day.

2.3.6 Grounding

A proper grounding system is crucial for ensuring stable and reliable operation, as well as preventing lightning strikes and interference. Carefully check the grounding conditions at the installation site according to the grounding requirements, and complete grounding properly based on the site situation.

- Safety Grounding

Ensure that the power distribution system is securely grounded if the equipment uses the AC power supply. Otherwise, electric shocks may occur when the insulation resistance between the power module and the chassis decreases.

Caution

- The building should provide a protective ground connection to ensure that the equipment is connected to a protective ground.
 - Verify that the AC socket is reliably connected to the protective grounding system of the building. If not, a protective grounding wire should be used to connect the protective grounding lug of the AC socket to the protective grounding system of the building.
-

- Lightning Grounding

The lightning protection system is an independent system composed of a lightning rod, a downlead conductor, and a connector connected to the grounding system. The grounding system is typically used for power reference grounding and safety grounding. Lightning grounding is required only for facilities, and is not required for the equipment.

- EMC Grounding

Electromagnetic compatibility (EMC) grounding includes shielded grounding, filter grounding, noise and interference suppression, and level reference.

2.3.7 Preventing Electromagnetic Interference

- Take interference prevention measures for the power supply system.
- Keep the equipment away from the grounding system or lightning protection grounding system of the power facility.
- Keep the equipment far away from high-frequency current equipment such as high-power radio transmitting stations and radar launchers.
- Take electromagnetic shielding measures when necessary.

2.3.8 Surge Protection

Although the equipment can guard against lightning strikes, strong lightning strikes may still damage the equipment. Take the following surge protection measures:

- Ensure that the grounding wire is in good contact with the ground.
- Ensure that the neutral point of the AC power socket is in good contact with the ground.
- Install a power arrester in front of the power input end to enhance surge protection for the power supply.

2.3.9 Installation Site

Regardless of whether the equipment is installed on a wall or a workbench, ensure that the following conditions are met:

- Maintain a proper clearance around the equipment for heat dissipation.
- Alternatively, place the equipment on a clean workbench. The installation of air conditioners is recommended in hot areas.

2.4 Tools

Table2-4 Tools

Common Tools	Phillips screwdriver, cables, cage nuts, diagonal pliers, cable ties, and grounding wires
Dedicated Tools	Anti-ESD gloves, wire stripper, crimping pliers, RJ45 crimping pliers, and wire cutter
Meter	Multimeter

 **Note**

The equipment is delivered without a toolkit. Prepare the preceding tools by yourself.

3 Installing the Switch

⚠ Caution

Before installing the equipment, ensure that guidelines and requirements in Chapter 2 have been met.

3.1 Before You Begin

- The installation site provides sufficient space for heat dissipation.
- The installation site meets the temperature and humidity requirements.
- The power supply is available at the installation site, and its current meets the requirements.
- The Ethernet cables have been deployed at the installation site.
- Locate the emergency power-off switch in the room before installation. In the case of an accident, cut off the power supply immediately.

3.2 Installing the Switch

3.2.1 Wall Mount

i Note

- You need to prepare two M3 screws and two plastic expansion anchors for wall mounting.
 - For wall mounting, install the equipment only on concrete or other non-flammable surfaces.
-

The steps for wall mounting a switch are as follows:

- (1) Drill two holes at suitable positions on the wall with a spacing of 112.6 mm (4.43 in.). The hole diameter and depth depend on the specifications of the purchased plastic expansion anchors.
- (2) Insert two plastic expansion anchors into the drilled holes, and then screw two M3 screws into the plastic expansion anchors.

i Note

- Ensure that the distance between the inner side of the screw heads and the outer edge of the plastic expansion anchors is at least 2.5 mm (0.1 in.) to securely mount the equipment onto the screws.
 - The equipment appearance shown in the installation diagram is for reference only.
-

- (3) Mount the equipment on the two M3 screws, as shown in the following figure.

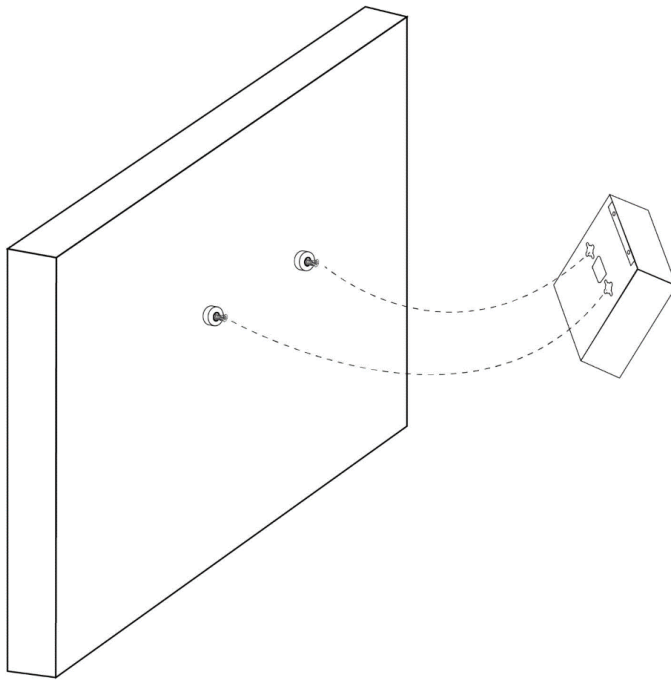
Figure3-1 Mounting the Switch on a Wall

3.2.2 Workbench Mount

If wall mounting is not feasible, place the switch on a clean workbench and choose a location where it is unlikely to be touched, to ensure the safety and stability of the switch.

3.3 Grounding the Equipment

Note

- If the equipment is installed on a workbench, connect the grounding wire to the nearest grounding bar or grounding point based on the onsite situation.
 - The grounding wire is not delivered with the equipment and needs to be purchased by the customer.
-

The equipment has a grounding stud on the rear panel. You are advised to connect the system grounding wire to it before using the equipment.

- (1) Purchase a grounding wire and connect one end to the grounding stud at the rear of the equipment.
 - (2) Connect the other end of the grounding wire to the nearest grounding bar or grounding point.
-

Caution

- To avoid personal injury and equipment damage, connect the switch to earth ground properly. The grounding resistance between the chassis and the ground should be less than 1 ohm.
 - The O&M personnel should verify whether the AC socket is reliably connected to the protective ground of the building. If not, the O&M personnel should use a protective grounding wire to connect the protective grounding lug of the AC socket to the protective ground of the building.
 - The power socket should be installed near the equipment and easily accessible.
 - During the equipment installation, connect the grounding wire first and disconnect it last.
-

- The sectional area of a grounding wire should be determined according to the possible maximum current. Grounding wires with good conductors should be used.
 - Do not use bare wires.
-

3.4 Connecting Cables

Caution

- All cables must be routed indoors. Take surge protection measures if they need to be routed outdoors.
 - When connecting an optical cable, connect the transmit (TX) port on the local equipment to the receive (RX) port on the peer equipment, and vice versa.
-

After the switch is installed, connect the switch to other equipment according to the following steps:

- (1) Connect the power cord delivered with the switch to the power strip.
- (2) Connect the RJ45 connector of a twisted pair to an Ethernet port on the switch, and the other end to downlink equipment.
- (3) Insert an optical transceiver into the optical port first according to the panel identification. Then connect a single-mode fiber (SMF) or multimode fiber (MMF) to the corresponding optical transceiver, during which the transmitting and receiving ends of the optical cable should be distinguished.

3.5 Bundling Cables

3.5.1 Precautions

- Bundle the power cord and other cables in an esthetically pleasing way.
- Make sure that the optical cables at the connectors have natural bends or bends of large radius.
- Do not bind optical cables and twisted pairs too tightly, as this may press the cables and affect their service life and transmission performance.

3.5.2 Bundling Procedure

- (1) Bind the drooping part of the optical cables and twisted pairs, and lead them to both sides of the chassis for convenience.
- (2) Bind the power cord closely along the bottom of the chassis, in a straight line wherever possible.

3.6 Verifying Installation

Caution

Please turn off the power to avoid personal injury and damage to components caused by incorrect connection.

- Verify that the grounding wire is connected.
- Verify that the cables including power cords are properly connected.
- Verify that cables connected to ports are routed indoors.
- Verify that the surge protection socket and Ethernet port arrester are installed, if outdoor cabling exists.

- Verify that there is a minimum clearance of 10 cm (3.94 in.) around the switch.

4 Commissioning

4.1 Power-on

- (1) Checklist Before Power-on
 - The switch is properly grounded.
 - The power cord is properly connected.
 - The power supply voltage meets the requirement of the switch.
- (2) Checklist After Power-on (Recommended)
 - The switch LEDs are in the normal state.
 - Service ports can forward data properly.

4.2 Logging In to the Management Interface

- (1) Connect a PC to an Ethernet port on the switch through an Ethernet cable.
- (2) Set the IP address of the PC to 10.44.77.XXX (Range: 1–254, excluding 200).

Figure4-1 Changing the IP Address

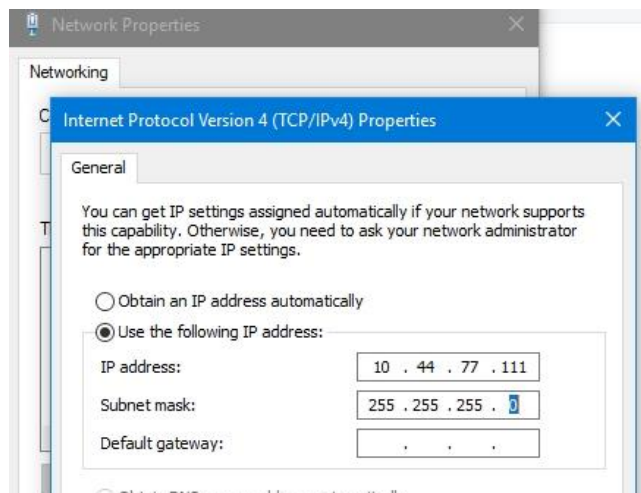

- (3) Open a browser, enter 10.44.77.200 in the address bar, and press Enter. On the login page, set a password and log in.
- (4) Perform equipment commissioning and configuration based on service requirements.

Note

For security purposes, you are advised to change the password regularly.

5 Troubleshooting

5.1 General Troubleshooting Flowchart

Note

You can determine whether each checking item in the process is normal based on the information provided in the previous chapters "Overview" and "Installing the Switch."

Figure5-1 General Troubleshooting Flowchart

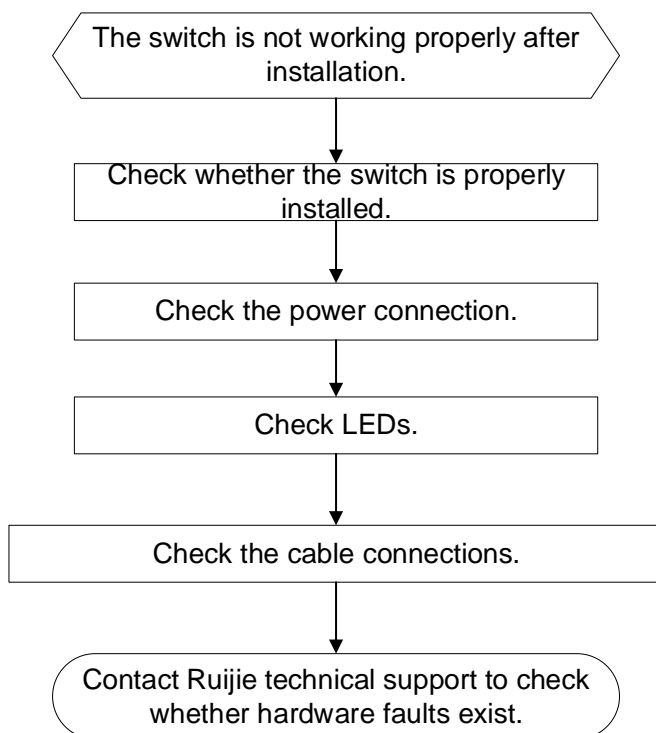

5.2 Common Faults

Table5-1 Common Faults and Troubleshooting

Symptom	Possible Cause	Suggested Action
The system status LED is off after the switch is powered on.	No power is supplied to the switch or the power cord is loosely connected.	Check whether the power socket in the equipment room is normal and whether the power cord is loosely connected to the switch.
An RJ45 port is disconnected or a frame	The twisted pair is not connected properly.	Replace the twisted pair.

Symptom	Possible Cause	Suggested Action
sending/receiving error occurs.	The cable length exceeds 100 m (328.08 ft.).	Use an optical cable for data transmission or connect to an intermediate switch for relay.
	The port is specially configured and does not work in the same mode as that of the interconnected switch.	Check whether the port is configured to work in the same mode as that of the interconnected switch.
An optical port is not reachable.	The transmit and receive ends are connected incorrectly.	Exchange the transmit and receive ends of the optical cable.
	The types of the interconnected optical transceivers do not match.	Replace with one compatible optical transceiver.
	The optical cable type does not meet the requirements.	Replace the optical cable with a qualified one.
	The optical cable length is beyond the allowed length marked on the optical transceiver.	Use an optical cable with the required length.
	The optical cable or connector is contaminated.	Clean the connector with a lint-free cloth or a cleaning pen.
The login password cannot be retrieved.	The password is forgotten, and the equipment is not connected to the network or Ruijie Cloud.	Press and hold the Reset button to restore to factory settings.
	If the equipment is connected to Ruijie Cloud or a network, its login password is updated to the project or global management password.	If the equipment is connected to the cloud, log in using the project management password. If the equipment is connected to a network, log in using the global management password.
The Ethernet ports are transmitting and receiving frames normally, but their LEDs are off.	<p>The status of the Ethernet port LEDs is incorrectly displayed.</p> <p>The DIP switch is set to LED mode 2. As a result, the Ethernet port LEDs display the PoE status, but PoE is disabled on the ports.</p>	Set the DIP switch to LED mode 1 so that the Ethernet port LEDs display the data receiving and sending status.

6 Appendix

6.1 Connectors and Media

6.1.1 100r100Or1000BASE-T Port

The 10/100/1000BASE-T port supports auto-negotiation for 10 Mbps, 100 Mbps, and 1000 Mbps connections and also supports auto MDI/MDIX Crossover.

Compliant with IEEE 802.3ab, a 1000BASE-T port connects to a 100-ohm Category 5 (CAT5) or Category 5 Enhanced (CAT5e) Unshielded Twisted Pair (UTP), or recommended Shielded Twisted Pair (STP) cable with a maximum distance of 100 m (328.08 ft.).

The 1000BASE-T port requires that all four pairs of wires be connected for data transmission. [Figure6-1](#) shows twisted pair connections for the 1000BASE-T port.

Figure6-1 Twisted Pair Connections for a 1000BASE-T Port

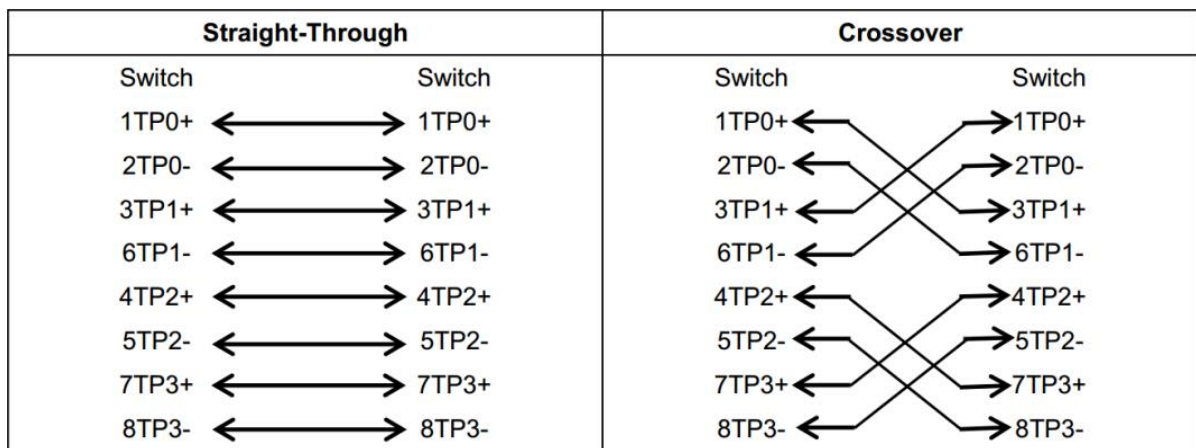

In addition to cables with the above-mentioned specifications, the 10/100BASE-T port can also be connected using 100-ohm CAT3, CAT4, and CAT5 cables at 10 Mbps or using 100-ohm CAT5 cables with a maximum distance of 100 m (328.08 ft.). The following table shows pin assignments for a 10/100BASE-T port.

Table6-1 10/100BASE-T Pin Assignment

Pin	Socket	Plug
1	Input Receive Data+	Output Transmit Data+
2	Input Receive Data-	Output Transmit Data-
3	Output Transmit Data+	Input Receive Data+
6	Output Transmit Data-	Input Receive Data-
4, 5, 7, and 8	Not Used	Not Used

The following table shows wiring of straight-through and crossover cables for a 10/100BASE-T port.

Figure6-2 Twisted Pair Connections for a 10/100BASE-T Port

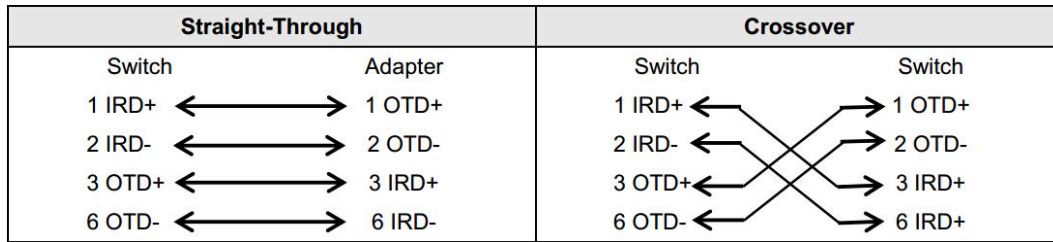

6.1.2 Optical Cable Connection

Select a single-mode fiber (SMF) or multimode fiber (MMF) for connections based on the type of the optical transceiver inserted into an optical port. [Figure6-3](#) shows the connections.

Figure6-3 Connecting the Optical Cables

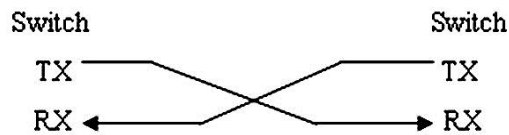

6.2 SFP Transceivers

Ruijie provides SFP transceivers (mini-GBIC) based on the port types. You can select one that suits your specific needs. In addition to the following 1GE SFP transceivers, the 1GE copper transceiver Mini-GBIC-GT is also supported. This document provides models and technical specifications of some 1GE SFP transceivers for reference. For details about the technical specifications, see *Ruijie Transceiver Installation and Reference Guide*.

Table6-2 1GE Mini-GBIC (SFP) Models and Technical Specifications

Model	Wavelength (nm)	Fiber Type	DDM Supported (Yes/No)	Transmit Power (dBm)		Receive Power (dBm)	
				Min	Max	Min	Max
MINI-GBIC-SX-MM850	850	MMF	Yes	-9	-3	-20	-3
MINI-GBIC-LX-SM1310	1310	SMF	Yes	-9	-3	-26	0
GE-SFP-LH40-SM1310-BIDI	1310TX/1550RX	SMF	Yes	-3	3	-25	0
GE-SFP-LH40-SM1550-BIDI	1550TX/1310RX	SMF	Yes	-3	3	-25	0

GE-SFP-LX20-SM1310-BIDI	1310TX/1550RX	SMF	Yes	-8	-3	-23	-3
GE-SFP-LX20-SM1550-BIDI	1550TX/1310RX	SMF	Yes	-8	-3	-23	-3
MINI-GBIC-LH40-SM1310	1310	SMF	Yes	-5	0	-25	-3
MINI-GBIC-ZX80-SM1550	1550	SMF	Yes	-3	3	-26	-3
GE-SFP-LX03-SM1310-BIDI-I	1310TX/1550RX	SMF	Yes	-9	-3	-22	-3
GE-SFP-LX03-SM1550-BIDI-I	1550TX/1310RX	SMF	Yes	-9	-3	-22	-3
SFP-MM850	850	MMF	Yes	-9.5	-3	-17	-3
SFP-SM1310	1310	SMF	Yes	-9	-3	-20	-3

Table6-3 1GE SFP Copper Transceivers

Standard	1000BASE-T SFP Module	DDM Supported (Yes/No)
1000BASE-T	Mini-GBIC-GT	No

Table6-4 Cabling Specifications of SFP Transceivers

SFP Transceiver Model	Port Type	Fiber Type	Core Size (µm)	Max Cabling Distance
SFP-SM1310	LC	SMF	9/125	10 km (6.21 miles)
MINI-GBIC-LX-SM1310	LC	SMF	9/125	10 km (6.21 miles)
GE-SFP-LH40-SM1310-BIDI	LC	SMF	9/125	40 km (24.85 miles)
GE-SFP-LH40-SM1550-BIDI	LC	SMF	9/125	40 km (24.85 miles)
GE-SFP-LX20-SM1310-BIDI	LC	SMF	9/125	20 km (12.43 miles)
GE-SFP-LX20-SM1550-BIDI	LC	SMF	9/125	20 km (12.43 miles)
MINI-GBIC-LH40-SM1310	LC	SMF	9/125	40 km (24.85 miles)
MINI-GBIC-ZX80-SM1550	LC	SMF	9/125	80 km (49.71 miles)
GE-SFP-LX03-SM1310-BIDI-I	LC	SMF	9/125	3 km (1.86 miles)
GE-SFP-LX03-SM1550-BIDI-I	LC	SMF	9/125	3 km (1.86 miles)
MINI-GBIC-SX-MM850	LC	MMF	62.5/125	275 m (902.23 ft.)

SFP Transceiver Model	Port Type	Fiber Type	Core Size (μm)	Max Cabling Distance
			50/125	550 m (1,804.46 ft.)
SFP-MM850	LC	MMF	62.5/125	275 m (902.23 ft.)
			50/125	550 m (1,804.46 ft.)
Mini-GBIC-GT	RJ45 Ethernet cable	CAT5 or better UTP or STP cable		100 m (328.08 ft.)

⚠ Caution

- For optical transceivers with a cabling distance of no less than 40 km (24.85 miles), install an optical attenuator to avoid overload on an optical receiver when using short-distance SMFs.
- An optical transceiver is a laser transmitter. Do not look into the light source to prevent it from burning your eyes.
- To keep the optical transceiver clean, make sure that the unused ports remain capped.

Table6-5 BIDI Optical Transceiver Pairing

Rate/Distance	Pairing Model
1000 Mbps/3 km (1.86 miles)	<ul style="list-style-type: none"> ● GE-SFP-LX03-SM1310-BIDI-I ● GE-SFP-LX03-SM1550-BIDI-I
1000 Mbps/20 km (12.43 miles)	<ul style="list-style-type: none"> ● GE-SFP-LX20-SM1310-BIDI ● GE-SFP-LX20-SM1550-BIDI
1000 Mbps/40 km (24.85 miles)	<ul style="list-style-type: none"> ● GE-SFP-LH40-SM1310-BIDI ● GE-SFP-LH40-SM1550-BIDI

⚠ Caution

BIDI optical transceivers must be used in pairs. For example, if GE-SFP-LX20-SM1310-BIDI is used at one end, GE-SFP-LX20-SM1550-BIDI must be used at the other end.

6.3 Lightning Protection

6.3.1 Installing the AC Power Arrester (Power Strip with Surge Protection)

When an alternating current (AC) power cord is introduced from outdoors and directly connected to the AC power port of the switch, the power port must be connected to an external power arrester to safeguard the switch against lightning strikes. The power arrester can be fixed on the rack, workbench, or wall in the equipment room by using cable ties and screws. AC power enters the power arrester before entering the switch.

Figure6-4 Power Arrester

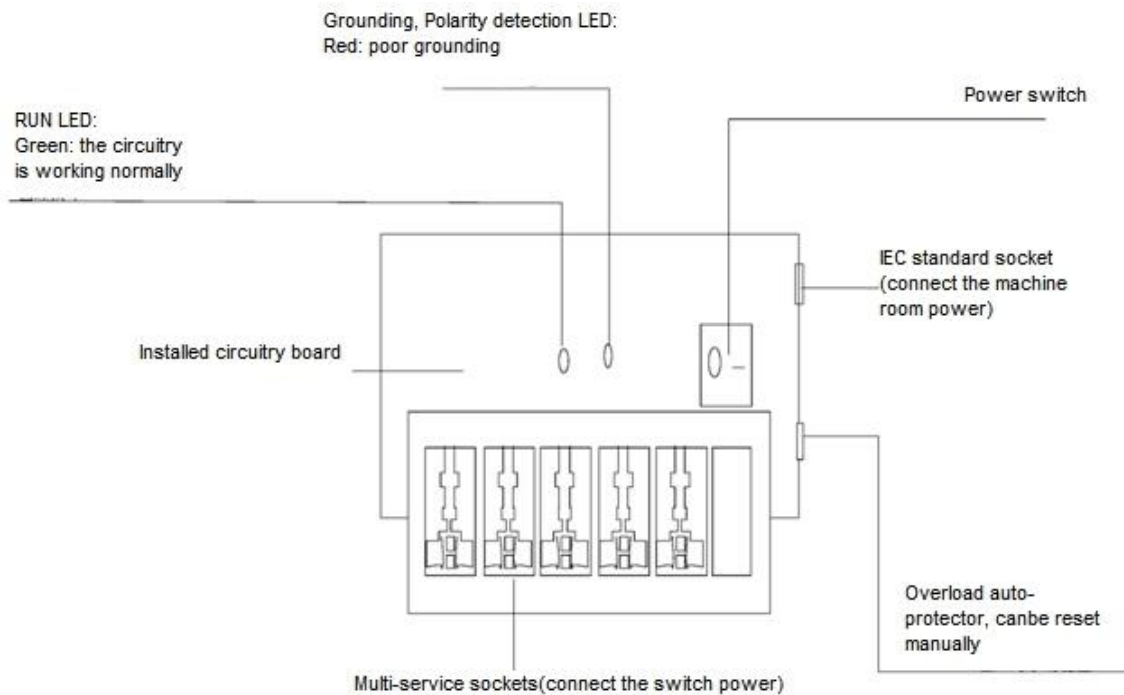

⚠ Caution

The power arrester is not delivered with the equipment. Please purchase it based on actual requirements.

Precautions during the installation:

- Make sure that the PE terminal of the power arrester is well grounded.
- After the AC power plug of the switch is connected to the socket of the power arrester, the lightning protection function is implemented only if the running status LED is green and the alarm LED is off.
- If the alarm LED on the power arrester is red, check whether it is caused by a poor grounding connection or by the reversed connection of the neutral and live wires. The detection method is as follows: Use a multimeter to measure the polarity of the power arrester when the alarm LED is red. If the neutral wire is on the left and the live wire is on the right (facing the socket), the PE terminal of the power arrester is not grounded. If not, the polarity of the power arrester should be reversed. In this case, open the power arrester and reverse its polarity. If the alarm LED is still red, the PE terminal of the power arrester is not grounded.

6.3.2 Installing the Ethernet Port Arrester

Please connect an Ethernet port arrester to the switch to prevent the damage by lightning strikes before connecting an outdoor Ethernet cable to the switch.

- Tools: Phillips screwdriver or flat-blade screwdriver, multimeter, and diagonal pliers
- Installation steps
 - a. Tear one side of the protective paper for the double-sided adhesive tape and paste the tape to the enclosure of the Ethernet port arrester. Tear the other side of the protective paper for the double-sided

- adhesive tape and paste the Ethernet port arrester to the switch enclosure. The paste position for the Ethernet port arrester should be as close to the grounding lug of the switch as possible.
- b. Based on the distance between the grounding lug of the switch and the Ethernet port arrester, cut the grounding cable of the Ethernet port arrester and firmly tighten the grounding cable to the grounding lug of the switch.
 - c. Use a multimeter to check whether the grounding cable for the arrester is in good contact with the grounding lug and the enclosure of the switch.
 - d. Connect the Ethernet port arrester by using an adapter cable (note that the external Ethernet cable is connected to the IN end, while the adapter cable connected to the switch is connected to the OUT end) and check whether the module LED is normal.
 - e. Use a nylon cable tie to bind the cables.

Figure6-5 Installing an Ethernet Port Arrester

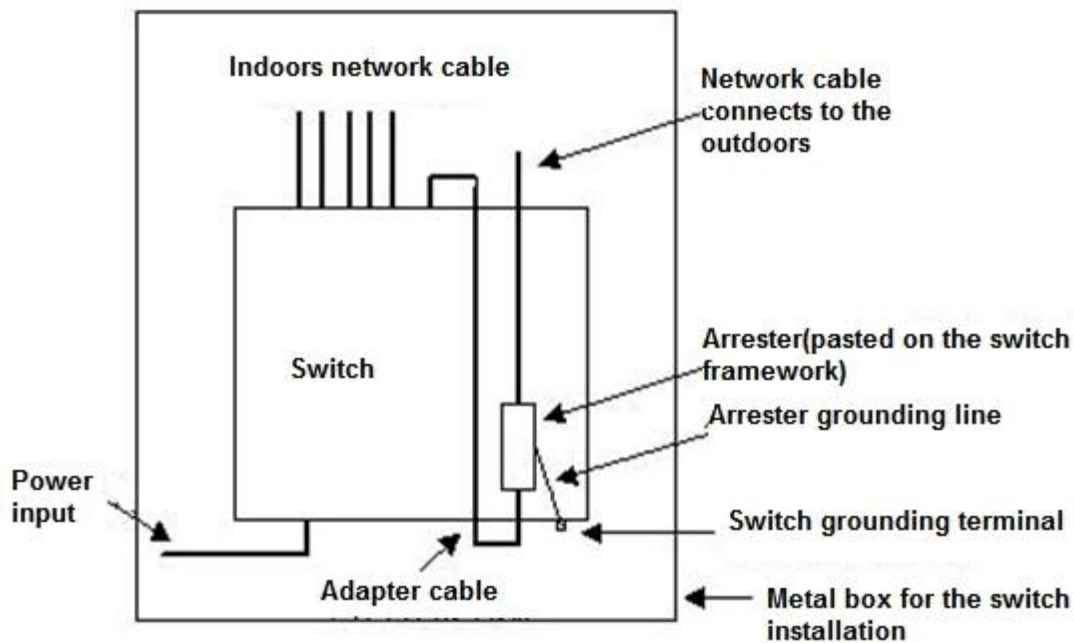

⚠ Caution

- The Ethernet port arrester is only for a 10 Mbps, 100 Mbps, or 1000 Mbps RJ45 port.
- The Ethernet port arrester is not delivered with the equipment. Please purchase it based on actual requirements. The user manual for Ethernet port arresters contains technical parameters and maintenance and installation instructions. Carefully read this manual during installation.

Pay attention to the following situations during the actual installation to avoid influencing the performance of an Ethernet port arrester:

- The arrester is incorrectly connected to the cables. Connect the external Ethernet cable to the IN end and connect the Ethernet port of the switch to the OUT end.
- The Ethernet port arrester is incorrectly grounded. The grounding cable of the arrester should be as short as

possible to ensure that it is in good contact with the grounding lug of the switch. Use a multimeter to confirm the contact condition after grounding.

- Not all Ethernet ports are installed with Ethernet port arresters. If outdoor Ethernet cables connect the switch ports to the peer equipment, Ethernet port arresters need to be installed on all the ports for the purpose of lightning protection.

6.4 Recommended Cabling

When the switch is installed in a standard 19-inch cabinet, secure the cables around the cable management brackets. Top cabling or bottom cabling is adopted according to the actual situation in the equipment room. All adapted connectors should be placed at the bottom of the rack in an orderly manner instead of outside the rack that is easy to touch. Power cords are routed beside the rack. Top cabling or bottom cabling is adopted according to the actual situation in the equipment room, such as the positions of the DC power distribution box, AC socket, or lightning protection box.

6.4.1 Requirement for the Minimum Bend Radius of Cables

- The bend radius of a fixed power cord, Ethernet cable, and flat cable should be over five times greater than their respective external diameters. The bend radius of these cables that are often bent or plugged should be over seven times greater than their respective external diameters.
- The bend radius of a fixed common coaxial cable should be over seven times greater than its external diameter. The bend radius of these cables that are often bent or plugged should be over 10 times greater than their respective external diameters.
- The minimum bend radius of a high-speed cable, such as an SFP+ cable, should be 5 times the overall diameter of the cable. If the cable is constantly bent, plugged or unplugged, the bend radius should be 10 times the overall diameter.
- The minimum bend radius of optical cables should meet the following requirements.
 - The diameter of the optical cable tray should be no less than 25 times greater than that of the optical cable.
 - When an optical cable is moved, its bend radius should be no less than 20 times greater than its diameter.
 - During cabling of an optical cable, its bend radius should be no less than 10 times greater than its diameter.

6.4.2 Precautions for Cable Bundling

- Before cables are bundled, mark labels and stick the labels to cables wherever appropriate.
- Cables should be neatly and properly bundled in the rack without twisting or bending, as shown in [Figure6-6](#).

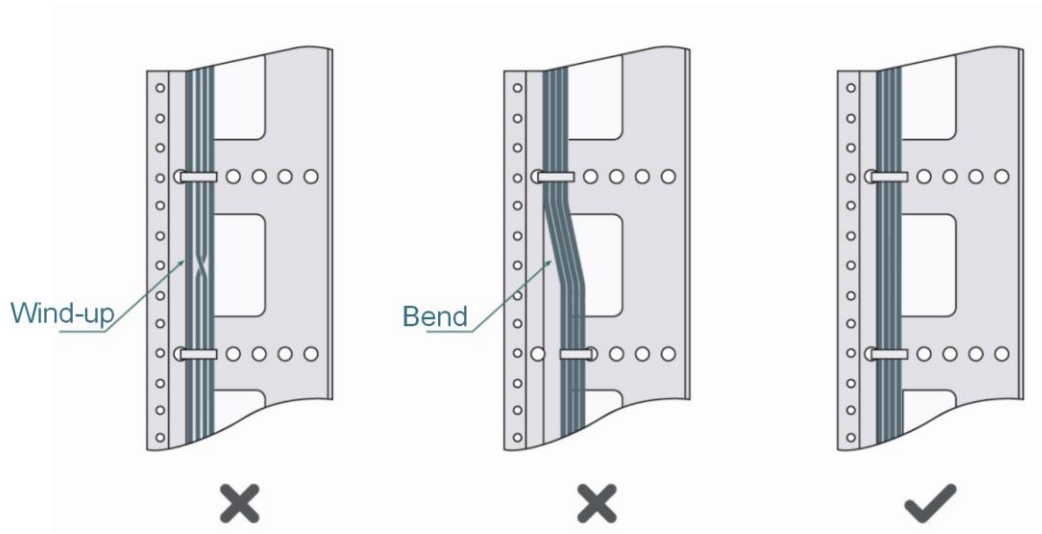
Figure6-6 Bundling Cables (1)

- Cables of different types (such as power cords, signal cables, and grounding wires) should be separated in cabling and bundling. Mixed bundling is not allowed. When they are close to each other, you are advised to adopt crossover cabling. In the case of parallel cabling, maintain a minimum distance of 30 mm (1.18 in.) between power cords and signal cables.
- The cable management brackets and cabling troughs inside and outside the rack should be smooth without sharp corners.
- The metal holes traversed by cables should have a smooth and fully rounded surface or an insulated lining.
- Use cable ties to bundle cables properly. Please do not connect two or more cable ties to bundle cables.
- After bundling up cables with cable ties, cut off the remaining part. The cut should be smooth and trim without sharp corners, as shown in [Figure6-7](#).

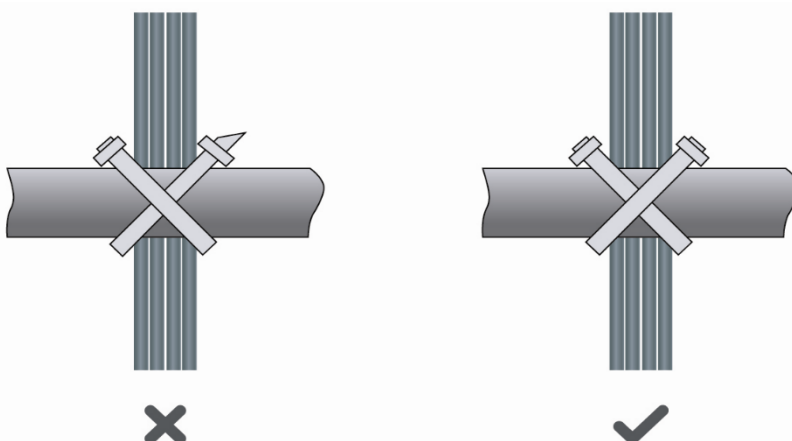
Figure6-7 Bundling Cables (2)

- When cables need to be bent, bundle them first but do not tie cables within the bend. Otherwise, stress may be generated on the cables and cause the wires inside to break, as shown in [Figure6-8](#).

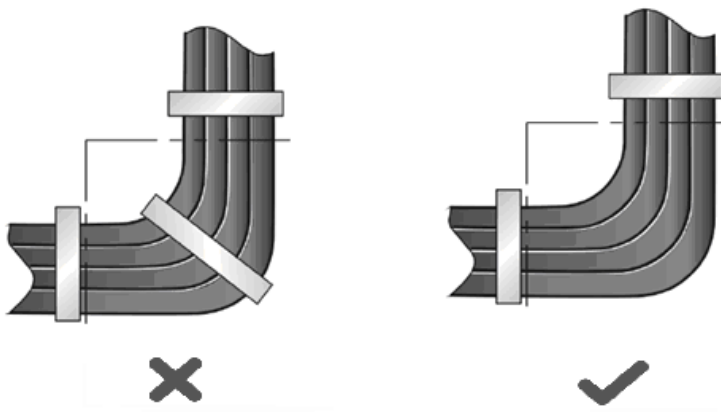
Figure6-8 Bundling Cables (3)

- Cables not to be assembled or the remaining parts of cables should be folded and placed in a proper position of the rack or cable management trough. The proper position refers to a position that does not affect the equipment running or damage the equipment or cables.
- Power cords must not be bundled on the guide rails of moving parts.
- The power cords connecting moving parts such as door grounding wires should be reserved with some excess after being assembled to avoid suffering tension or stress. When a moving part reaches the installation position, the remaining cable part should not touch heat sources, sharp corners, or sharp edges. If heat sources must be touched, high-temperature cables should be used.
- When using screw threads to secure a cable lug, ensure that the bolt or screw is properly tightened and take measures to prevent it from loosening, as shown in [Figure6-9](#).

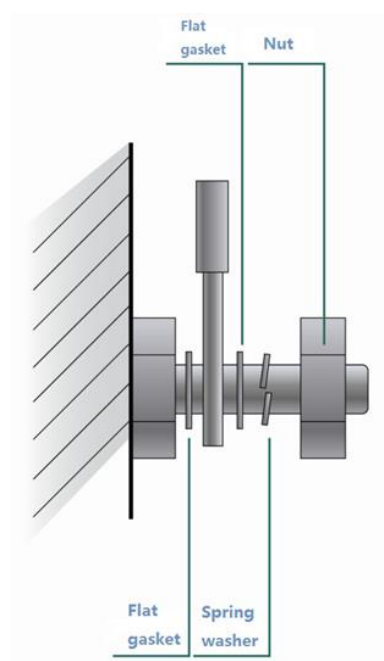
Figure6-9 Fastening Cables

- Hard power cords should be secured near the cable termination area to prevent stress on the cable

termination area and cables.

- Do not use tapping screws to secure cable lugs.
- Power cords of the same type and in the same cabling direction should be bundled up into cable bunches, with cables in cable bunches clean and straight.
- Bundle cables by using cable ties according to the following table.

Cable Bunch Diameter	Bundling Spacing
10 mm (0.39 in.)	80–150 mm (3.15–5.91 in.)
10–30 mm (0.39–1.18 in.)	150–200 mm (5.91–7.87 in.)
30 mm (1.18 in.)	200–300 mm (7.87–11.81 in.)

- Do not tie cables or bundles in a knot.
- For wiring terminal blocks (such as circuit breakers) with cord end terminals, the metal part of the cord end terminal should not be exposed outside the terminal block when assembled.

6.5 Site Selection

- The equipment room should be at least 5 km (3.11 miles) away from heavy pollution sources, such as smelters, coal mines, and thermal power plants. The equipment room should be at least 3.7 km (2.30 miles) away from medium pollution sources, such as the chemical factory, rubber factory, and electroplating factory. The equipment room should be at least 2 km (1.24 miles) away from light pollution sources, such as the food factory and leather plant. If the pollution source is unavoidable, the equipment room should be located on the windward side of the pollution source perennially with advanced protection.
- The equipment room should be at least 3.7 km (2.30 miles) away from the sea or salt lake. Otherwise, the equipment room must be sealed, with an air conditioner installed for temperature control. Saline soil cannot be used for construction. Otherwise, you should select equipment with advanced protection against severe environments.
- Do not build the equipment room in the proximity of livestock farms. Otherwise, the equipment room should be located on the windward side of the pollution source perennially. The previous livestock house or fertilizer warehouse cannot be used as the equipment room.
- The equipment room should be firm enough to withstand severe weather conditions such as windstorms, heavy rain, and dense dust. If the dust is unavoidable, keep the door and window away from the pollution source.
- The equipment falls into Class A. Therefore, the equipment room should be located away from the residential area. Otherwise, the equipment room should meet construction specifications to avoid noise and radio interference.
- Make sure the air vent of the equipment room is away from the sewage pipe, septic tank, and sewage treatment tank. Keep the equipment room under positive pressure to prevent corrosive gas from entering the equipment room to corrode components and circuit boards.
- Keep the equipment room away from industrial boilers and heating boilers.
- The equipment room should be on the second floor or higher. Otherwise, the equipment room floor should

be 600 mm (23.62 in.) higher than the highest flood level ever recorded.

- Make sure no cracks or holes exist in the wall and floor. If there are cable entries in the wall or window, take proper sealing measures. Ensure that the wall is flat, wear-resistant, and dust-free, meeting standards for flame resistance, soundproofing, heat absorption, dust reduction, and electromagnetic shielding.
- Keep the door and the window closed to make the equipment room sealed.
- You are advised to use the steel door for soundproofing.
- Do not use sulfur-containing materials.
- Keep the air conditioner from blowing wind straight toward the equipment or blowing water drops from the window or air vent toward the equipment.

Contents

1 Overview	4
1.1 About the RG-ES211GS-P	4
1.2 Equipment Appearance	4
1.2.1 Front Panel.....	4
1.2.2 Rear Panel	5
1.2.3 LEDs	6
1.3 Cooling.....	7
1.4 Technical Specifications	7
2 Preparing for Installation	10
2.1 Package Contents.....	10
2.2 Safety Guidelines.....	10
2.2.1 General Precautions	10
2.2.2 Chassis-Lifting Guidelines	10
2.2.3 Electricity Safety	11
2.2.4 Preventing ESD Damage.....	12
2.2.5 Laser Safety	12
2.3 Site Requirements	12
2.3.1 Floor Loading	12
2.3.2 Airflow.....	13
2.3.3 Space	13
2.3.4 Temperature and Humidity.....	13
2.3.5 Cleanliness.....	13

2.3.6 Grounding	14
2.3.7 Preventing Electromagnetic Interference	14
2.3.8 Surge Protection	15
2.3.9 Installation Site.....	15
2.4 Tools	15
3 Installing the Switch	16
3.1 Before You Begin.....	16
3.2 Installing the Switch	16
3.2.1 Wall Mount	16
3.2.2 Workbench Mount.....	17
3.3 Grounding the Equipment.....	17
3.4 Connecting Cables.....	18
3.5 Bundling Cables.....	18
3.5.1 Precautions	18
3.5.2 Bundling Procedure	18
3.6 Verifying Installation.....	18
4 Commissioning.....	20
4.1 Power-on.....	20
4.2 Logging In to the Management Interface.....	20
5 Troubleshooting.....	21
5.1 General Troubleshooting Flowchart	21
5.2 Common Faults.....	21
6 Appendix.....	23
6.1 Connectors and Media.....	23

6.1.1 10Or100Or1000BASE-T Port	23
6.1.2 Optical Cable Connection	24
6.2 SFP Transceivers	24
6.3 Lightning Protection	27
6.3.1 Installing the AC Power Arrester (Power Strip with Surge Protection)	27
6.3.2 Installing the Ethernet Port Arrester	28
6.4 Recommended Cabling	29
6.4.1 Requirement for the Minimum Bend Radius of Cables	30
6.4.2 Precautions for Cable Bundling	30
6.5 Site Selection	33

1 Overview

1.1 About the RG-ES211GS-P

The RG-ES211GS-P Ethernet switch provides ten 10/100/1000BASE-T ports, one 1GE SFP port, one Reset button, and several LEDs on the front panel, along with a 54 V DC power port, a DIP switch, and a grounding stud on the rear panel. Ports 1–8 support Power over Ethernet (PoE) Out.

Figure 1-1 RG-ES211GS-P Appearance



Note

- 1GE SFP port: Supports only 1GE SFP optical transceivers (not compatible with 100 Mbps optical cables).
- 10/100/1000BASE-T port: Supports auto-negotiation at 10 Mbps, 100 Mbps, and 1000 Mbps.

1.2 Equipment Appearance

1.2.1 Front Panel

Figure 1-2 Front Panel of the RG-ES211GS-P

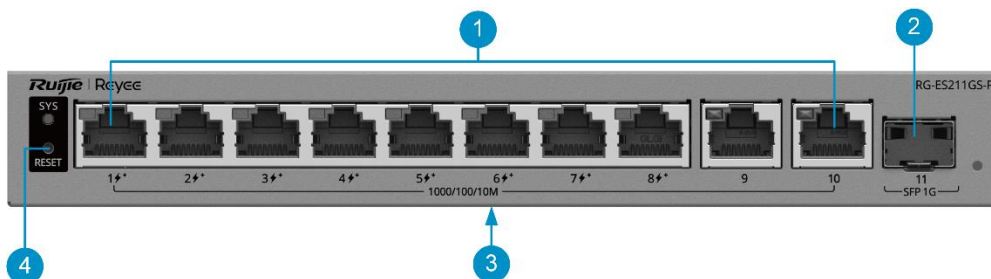

Note

⚡+ indicates the PoE+ ports, which are compliant with IEEE 802.3at and IEEE 802.3af.

Table 1-1 Components on the Front Panel

No.	Component	Silkscreen	Description
1	RJ45 port	1–10	10/100/1000BASE-T ports, with ports 1–8 supporting PoE Out.
2	SFP port	11	1GE SFP port, supporting 1GE SFP transceiver (hot-swappable)
3	Nameplate	-	It is located at the bottom of the switch.
4	Reset button	RESET	<ul style="list-style-type: none"> ● Press and hold the button for less than 2 seconds. The switch is reset. ● Press and hold the button for 2–5 seconds. No action is performed. ● Press and hold the button for more than 5 seconds, and release the button until the system status LED starts blinking to restore factory settings and restart the switch.

Note

For details about LEDs on the front panel, see "LEDs."

1.2.2 Rear Panel

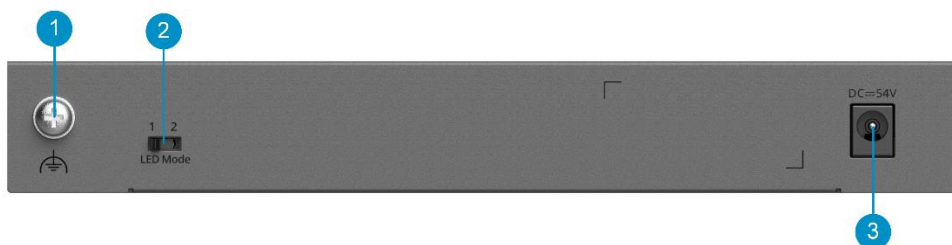
Figure 1-3 Rear Panel of the RG-ES211GS-P**Table 1-2 Components on the Rear Panel**

No.	Component	Description
1	Grounding stud	It is connected to a grounding wire.
2	DIP switch	<p>Toggle the DIP switch to change the LED modes of ports 1–8.</p> <ul style="list-style-type: none"> ● LED mode 1 (switching mode): When the DIP switch is toggled to the left, the port LEDs display the data transmission status. ● LED mode 2 (PoE mode): When the switch is toggled to the right, the port LEDs display the PoE status.
3	DC power port	<p>It is connected to a 54 V DC power source to supply power to the switch.</p> <p>The matching DC power connector has an outer diameter of 5.5 mm (0.22 in.), an inner diameter of 2.1 mm (0.08 in.), and a depth of 10 mm</p>

No.	Component	Description
		(0.39 in.).

1.2.3 LEDs

Figure 1-4 RG-ES211GS-P LEDs

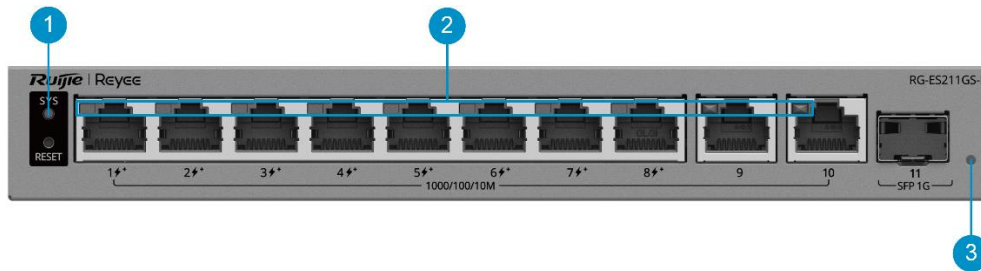

Table 1-3 LEDs

No.	Component	Silkscreen	Description
1	System status LED	SYS	<ul style="list-style-type: none"> ● Off: The switch is not powered on. ● Slow blinking green (0.5 Hz): The switch is operating normally but is not connected to Ruijie Cloud. ● Fast blinking green (10 Hz): The switch is upgrading or restarting, and is temporarily unavailable. ● Solid green: The switch is operating normally and connected to Ruijie Cloud. ● Slow blinking yellow (0.5 Hz): The PoE power is insufficient. ● Slow blinking red (0.5 Hz): A loop occurs on the switch with loop guard enabled.
2	RJ45 port LED	-	<p>LEDs of ports 1–8 support switching mode and PoE mode, which can be switched by toggling the DIP switch on the rear of the switch. LEDs of ports 9 and 10 support only switching mode.</p> <ul style="list-style-type: none"> ● Switching mode: <ul style="list-style-type: none"> ○ Off: The port is not connected. ○ Solid green: The port is operating at 1000 Mbps, 100 Mbps, or 10 Mbps, but is not receiving or sending data. ○ Blinking green: The port is operating at 1000 Mbps, 100 Mbps, or 10 Mbps, and is receiving or sending data. ● PoE mode: <ul style="list-style-type: none"> ○ Off: PoE is disabled on the port. ○ Solid green: PoE is enabled on the port. ○ Blinking green: PoE overload occurs on the port.
3	SFP port LED	-	<ul style="list-style-type: none"> ● Off: The port is not connected. ● Solid green: The port is operating at 1000 Mbps, but is not receiving or sending data. ● Blinking green: The port is operating at 1000 Mbps, and is receiving or sending data.

1.3 Cooling

The RG-ES211GS-P adopts fanless design and uses natural cooling. To ensure that the equipment works properly in the specified environment, a minimum clearance of 10 cm (3.94 in.) must be maintained around the equipment for air circulation and ventilation.

1.4 Technical Specifications

Warning

- This equipment is not suitable for use in locations where children are likely to be present.
- Operation of this equipment in a residential environment could cause radio interference.

Table 1-4 Technical Specifications

Parameter Type	Parameter Name	RG-ES211GS-P
System Specifications	Forwarding rate	16.36 Mpps
	Switching capacity	22 Gbps(bit/s)
	Flash memory	8 MB
Port Specifications	Total number of optical ports	1
	Total number of RJ45 ports	10
	Number of 10/100/1000BASE-T ports	10
	Number of 1GE SFP ports	1
	Reset button	1
	LEDs	1 x system status LED 10 x Ethernet port LEDs 1 x SFP port LED
	DIP switch	LED mode switch toggled to left (Mode 1): The port LED status indicates the status of traffic transmission. Solid green means that the port is link up, while blinking green means that the port is transmitting and receiving data.

Parameter Type	Parameter Name	RG-ES211GS-P
		LED mode switch toggled to right (Mode 2): The port LED status indicates the PoE status. Solid green means that the port is supplying power, while blinking green means that the port is in power overload state.
Power Supply and Consumption	Power supply	DC power adapter
	Power input	DC adapter: <ul style="list-style-type: none"> ● Rated input voltage: 100 V AC to 240 V AC, 50 Hz to 60 Hz ● Maximum input voltage: 90 V AC to 264 V AC, 47 Hz to 63 Hz ● Rated input current: 2 A Output : <ul style="list-style-type: none"> ● Rated output voltage: 54 V DC ● Maximum output current: 2.5 A
	Maximum power consumption	8.5 W (with no PoE load) 128.5 W (with full PoE load)
	Number of PoE Out ports	8
	Number of PoE/PoE+ Out ports	8
	PoE Out standard	PoE/PoE+ (IEEE 802.3af/at)
	PoE power pins	1–2 (+), 3–6 (-)
	PoE budget per port	30 W
	PoE budget	120 W
Dimensions and Weight	Product dimensions (W x D x H)	205mm x 105mm x 28mm (8.07 in. x 4.13 in. x 1.10 in.)
	Weight	0.45 kg (0.99 lbs) (without packaging materials)
	Shipping weight	1.19 kg (2.62 lbs)
	Casing	Metal
Interface	EEE	Yes
Environment and Reliability	Mounting options	Wall/Desk
	Hot swapping of cables	Hot swapping supported by the service port and power connector

Parameter Type	Parameter Name	RG-ES211GS-P
	Fan	Fanless design
	Cooling	Natural cooling
	MTBF	200,000 hours
	ESD protection	Air discharge: 8 kV Contact discharge: 6 kV
	Surge protection	Service port: ± 6 kV for common mode Power connector: ± 4 kV for common mode and ± 2 kV for differential mode
	Operating temperature	0°C to 40°C (32°F to 104°F)
	Storage temperature	-40°C to +70°C (-40°F to +158°F)
	Operating humidity	10% RH to 90% RH (non-condensing)
	Storage humidity	5% RH to 95% RH (non-condensing)
	Altitude	-500 m to +5,000 m (-1,640.42 ft. to +16,404.20 ft.)
Certification and Regulatory Compliance	EMC	EN 55032 EN 61000-3-2 EN 61000-3-3 EN 55035 EN 300 386
	Safety compliance	EN 62368-1 IEC 62368-1
	Certification	CE,CB

2 Preparing for Installation

2.1 Package Contents

Table 2-1 Package Contents

No.	Item	Quantity
1	RG-ES211GS-P switch	1
2	User Manual	1
3	Warranty Card	1
4	Power adapter	1
5	Power cord	1

Note

The package contents are subject to the purchase contract, and actual delivery may vary. Please check the items carefully against the package contents or purchase contract. If you have any questions, please contact the distributor.

2.2 Safety Guidelines

Note

- To avoid personal injury or equipment damage, review the safety guidelines in this chapter before you begin the installation.
 - The following safety guidelines may not include all the potentially hazardous situations.
-

2.2.1 General Precautions

- Never operate the equipment in a wet environment, and avoid any liquids inside it. Keep the chassis clean and dust-free.
- Keep the equipment away from heat sources.
- Keep the equipment away from walk areas.
- During installation and maintenance, do not wear loose clothing or ornament that may get caught in the chassis.
- Keep tools and accessories away from walk areas.

2.2.2 Chassis-Lifting Guidelines

- Avoid moving the equipment frequently.
- Turn off all power supplies and disconnect all cables before lifting or moving the equipment.

2.2.3 Electricity Safety

Warning

- Any deviation from standard or improper electrical operations can result in accidents such as fires or electric shocks, potentially causing severe or even fatal harm to both individuals and equipment.
 - Direct or indirect touch through a wet object on high-voltage and mains supply can bring a fatal danger.
-

- Always observe the local regulations and standards. Only qualified personnel should be allowed to operate the equipment.
- Carefully check the work area for potential hazards, including ungrounded power system, absent safety grounds, and damp floors.
- Locate the emergency power-off switch in the room before installation. In the case of an accident, cut off the power supply immediately.
- Never assume that power is connected to or disconnected from a circuit. Always check.
- Select the right leakage protector (also called "leakage current switch" or "leakage current breaker") for the power supply system. This equipment automatically disconnects the power supply in the event of leakage and the risk of electric shock. A leakage protector should meet the following requirements:
 - The rated leakage action current of each leakage protector must be at least twice the total maximum leakage current of all connected power supplies.

Example:

If a system has 16 identical power supplies, each with a maximum leakage current of 3.5 mA:

Total leakage current = $16 \times 3.5 \text{ mA} = 56 \text{ mA}$

For a 30 mA leakage protector:

Maximum number of power supplies per protector = $30 \text{ mA} / 3.5 \text{ mA} \approx 4$

Therefore, only four power supplies can be connected to one 30 mA leakage protector.

To support 16 power supplies, at least four 30 mA leakage protectors are required.

Always ensure:

Rated leakage operating current/2 > Total maximum leakage current of connected power supplies

- The rated leakage non-action current of a leakage protector should be 50% of the leakage action current. If the non-action current value is too small, the high sensitivity level can cause the circuit to break, leading to power cutoff and service interruption, even if the leakage current value is normal.

For example, if a leakage protector has a rated leakage action current of 30 mA, the rated leakage non-action current should be 15 mA. The leakage protector will not activate unless the leakage current exceeds 15 mA.

Caution

- To ensure personal safety, each leakage protector in the system must have a rated leakage action current equal to or below 30 mA, which is the recognized safety threshold for human body current. If the total leakage current of the system exceeds twice the 30 mA limit, the system must be equipped with two or more leakage protectors to maintain safety.
 - The leakage current values vary with equipment. For the leakage current value of each equipment model, see "Technical Specifications."
-

2.2.4 Preventing ESD Damage

- Ensure that the chassis is connected to earth ground.
- Keep the site as dust free as possible.
- Maintain appropriate humidity conditions.
- Before installing any pluggable modules, wear an anti-ESD wrist strap and make sure that it is properly grounded.
- Avoid contact between the printed circuit boards and clothing. The anti-ESD wrist strap only protects the printed circuit boards from ESD voltages on the body. ESD voltages on clothing can still cause damage.

2.2.5 Laser Safety

The equipment supports various types of optical transceivers, which are Class 1 laser products.

Precautions:

- When an optical transceiver is working, ensure that its port is connected to an optical cable or covered by a dust cap to keep out dust and prevent it from burning your eyes.
- Do not stare into an optical port.

Figure 2-1 Laser Product ID



Caution

Do not approach or stare into an optical port under any circumstances. This may cause permanent damage to your eyes.

2.3 Site Requirements

The equipment must be installed indoors for normal operation and prolonged service life.

The installation site must meet the following requirements.

2.3.1 Floor Loading

Assess the combined weight of the equipment and its accessories, such as chassis and power modules, and verify that the floor under the rack can bear the weight.

2.3.2 Airflow

The equipment adopts natural cooling. Reserve a sufficient clearance around the equipment to ensure proper ventilation.

2.3.3 Space

Do not install the equipment against a wall. Instead, maintain a minimum clearance of 10 cm (3.94 in.) around the equipment for heat dissipation and equipment maintenance.

2.3.4 Temperature and Humidity

To ensure the normal operation and a prolonged service life of the equipment, maintain an appropriate temperature and humidity in the installation environment.

Prolonged exposure to inappropriate temperature and humidity conditions can cause damage to the equipment.

- In an environment with high relative humidity, insulating materials are prone to poor insulation or even electricity leakage.
- In an environment with low relative humidity, insulating gaskets may shrink, resulting in screw loosening.
- In a dry environment, static electricity is more likely to occur, posing a risk to the internal circuits of equipment.
- A high temperature can accelerate the aging process of insulation materials, greatly reducing the availability of the equipment and severely affecting its service life.

2.3.5 Cleanliness

Dust poses a significant hazard to the equipment. Dust on the enclosure causes electrostatic adhesion, leading to poor contact of the metallic joints. Electrostatic adhesion is more likely to occur in an indoor environment with relatively low humidity, not only affecting the service life of the equipment, but also causing communication faults. The following table lists the requirements for dust concentration and particle size in the equipment room.

Table 2-2 Requirements for Dust

Particle Diameter	Unit	Concentration
≥ 0.5 μm	Particles/m ³	≤ 3.5 × 10 ⁶
≥ 5 μm	Particles/m ³	≤ 3.5 × 10 ⁶

Apart from dust, there are also requirements on the salt, acid, and sulfide in the air of the equipment room. These harmful substances will accelerate metal corrosion and component aging. Therefore, the equipment room should be properly protected against harmful gases, such as sulfur dioxide, hydrogen sulfide, nitrogen dioxide, and chlorine gas. The following table lists the limits on harmful gases.

Table 2-3 Requirements for Gases

Gas	Average (mg/m ³)	Maximum (mg/m ³)
Sulfur dioxide (SO ₂)	0.3	1.0
Hydrogen sulfide (H ₂ S)	0.1	0.5

Gas	Average (mg/m ³)	Maximum (mg/m ³)
Nitrogen dioxide (NO ₂)	0.5	1.0
Chlorine gas (Cl ₂)	0.1	0.3

 **Note**

Average refers to the average value of harmful gases measured in a week. **Maximum** refers to the upper limit of harmful gases measured in a week for up to 30 minutes every day.

2.3.6 Grounding

A proper grounding system is crucial for ensuring stable and reliable operation, as well as preventing lightning strikes and interference. Carefully check the grounding conditions at the installation site according to the grounding requirements, and complete grounding properly based on the site situation.

- Safety Grounding

Ensure that the power distribution system is securely grounded if the equipment uses the AC power supply. Otherwise, electric shocks may occur when the insulation resistance between the power module and the chassis decreases.

 **Caution**

- The building should provide a protective ground connection to ensure that the equipment is connected to a protective ground.
 - Verify that the AC socket is reliably connected to the protective grounding system of the building. If not, a protective grounding wire should be used to connect the protective grounding lug of the AC socket to the protective grounding system of the building.
-

- Lightning Grounding

The lightning protection system is an independent system composed of a lightning rod, a downlead conductor, and a connector connected to the grounding system. The grounding system is typically used for power reference grounding and safety grounding. Lightning grounding is required only for facilities, and is not required for the equipment.

- EMC Grounding

Electromagnetic compatibility (EMC) grounding includes shielded grounding, filter grounding, noise and interference suppression, and level reference.

2.3.7 Preventing Electromagnetic Interference

- Take interference prevention measures for the power supply system.
- Keep the equipment away from the grounding system or lightning protection grounding system of the power facility.
- Keep the equipment far away from high-frequency current equipment such as high-power radio transmitting stations and radar launchers.
- Take electromagnetic shielding measures when necessary.

2.3.8 Surge Protection

Although the equipment can guard against lightning strikes, strong lightning strikes may still damage the equipment. Take the following surge protection measures:

- Ensure that the grounding wire is in good contact with the ground.
- Ensure that the neutral point of the AC power socket is in good contact with the ground.
- Install a power arrester in front of the power input end to enhance surge protection for the power supply.

2.3.9 Installation Site

Regardless of whether the equipment is installed on a wall or a workbench, ensure that the following conditions are met:

- Maintain a proper clearance around the equipment for heat dissipation.
- Alternatively, place the equipment on a clean workbench. The installation of air conditioners is recommended in hot areas.

2.4 Tools

Table 2-4 Tools

Common Tools	Phillips screwdriver, cables, cage nuts, diagonal pliers, cable ties, and grounding wires
Dedicated Tools	Anti-ESD gloves, wire stripper, crimping pliers, RJ45 crimping pliers, and wire cutter
Meter	Multimeter

 **Note**

The equipment is delivered without a toolkit. Prepare the preceding tools by yourself.

3 Installing the Switch

⚠ Caution

Before installing the equipment, ensure that guidelines and requirements in Chapter 2 have been met.

3.1 Before You Begin

- The installation site provides sufficient space for heat dissipation.
- The installation site meets the temperature and humidity requirements.
- The power supply is available at the installation site, and its current meets the requirements.
- The Ethernet cables have been deployed at the installation site.
- Locate the emergency power-off switch in the room before installation. In the case of an accident, cut off the power supply immediately.

3.2 Installing the Switch

3.2.1 Wall Mount

i Note

- You need to prepare two M3 screws and two plastic expansion anchors for wall mounting.
 - For wall mounting, install the equipment only on concrete or other non-flammable surfaces.
-

The steps for wall mounting a switch are as follows:

- (1) Drill two holes at suitable positions on the wall with a spacing of 112.6 mm (4.43 in.). The hole diameter and depth depend on the specifications of the purchased plastic expansion anchors.
- (2) Insert two plastic expansion anchors into the drilled holes, and then screw two M3 screws into the plastic expansion anchors.

i Note

- Ensure that the distance between the inner side of the screw heads and the outer edge of the plastic expansion anchors is at least 2.5 mm (0.1 in.) to securely mount the equipment onto the screws.
 - The equipment appearance shown in the installation diagram is for reference only.
-

- (3) Mount the equipment on the two M3 screws, as shown in the following figure.

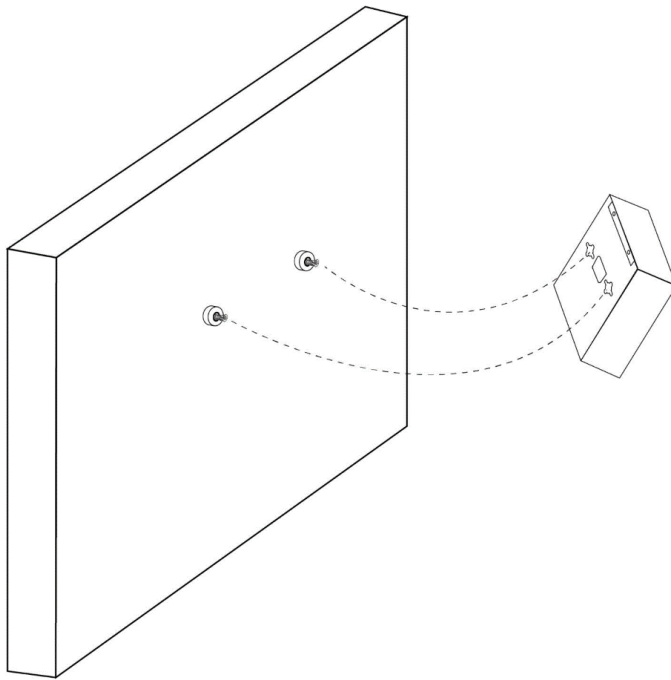
Figure 3-1 Mounting the Switch on a Wall

3.2.2 Workbench Mount

If wall mounting is not feasible, place the switch on a clean workbench and choose a location where it is unlikely to be touched, to ensure the safety and stability of the switch.

3.3 Grounding the Equipment

Note

- If the equipment is installed on a workbench, connect the grounding wire to the nearest grounding bar or grounding point based on the onsite situation.
 - The grounding wire is not delivered with the equipment and needs to be purchased by the customer.
-

The equipment has a grounding stud on the rear panel. You are advised to connect the system grounding wire to it before using the equipment.

- (1) Purchase a grounding wire and connect one end to the grounding stud at the rear of the equipment.
 - (2) Connect the other end of the grounding wire to the nearest grounding bar or grounding point.
-

Caution

- To avoid personal injury and equipment damage, connect the switch to earth ground properly. The grounding resistance between the chassis and the ground should be less than 1 ohm.
 - The O&M personnel should verify whether the AC socket is reliably connected to the protective ground of the building. If not, the O&M personnel should use a protective grounding wire to connect the protective grounding lug of the AC socket to the protective ground of the building.
 - The power socket should be installed near the equipment and easily accessible.
 - During the equipment installation, connect the grounding wire first and disconnect it last.
-

- The sectional area of a grounding wire should be determined according to the possible maximum current. Grounding wires with good conductors should be used.
 - Do not use bare wires.
-

3.4 Connecting Cables

Caution

- All cables must be routed indoors. Take surge protection measures if they need to be routed outdoors.
 - When connecting an optical cable, connect the transmit (TX) port on the local equipment to the receive (RX) port on the peer equipment, and vice versa.
-

After the switch is installed, connect the switch to other equipment according to the following steps:

- (1) Connect the power cord delivered with the switch to the power strip.
- (2) Connect the RJ45 connector of a twisted pair to an Ethernet port on the switch, and the other end to downlink equipment.
- (3) Insert an optical transceiver into the optical port first according to the panel identification. Then connect a single-mode fiber (SMF) or multimode fiber (MMF) to the corresponding optical transceiver, during which the transmitting and receiving ends of the optical cable should be distinguished.

3.5 Bundling Cables

3.5.1 Precautions

- Bundle the power cord and other cables in an esthetically pleasing way.
- Make sure that the optical cables at the connectors have natural bends or bends of large radius.
- Do not bind optical cables and twisted pairs too tightly, as this may press the cables and affect their service life and transmission performance.

3.5.2 Bundling Procedure

- (1) Bind the drooping part of the optical cables and twisted pairs, and lead them to both sides of the chassis for convenience.
- (2) Bind the power cord closely along the bottom of the chassis, in a straight line wherever possible.

3.6 Verifying Installation

Caution

Please turn off the power to avoid personal injury and damage to components caused by incorrect connection.

- Verify that the grounding wire is connected.
- Verify that the cables including power cords are properly connected.
- Verify that cables connected to ports are routed indoors.

- Verify that the surge protection socket and Ethernet port arrester are installed, if outdoor cabling exists.
- Verify that there is a minimum clearance of 10 cm (3.94 in.) around the switch.

4 Commissioning

4.1 Power-on

- (1) Checklist Before Power-on
 - The switch is properly grounded.
 - The power cord is properly connected.
 - The power supply voltage meets the requirement of the switch.
- (2) Checklist After Power-on (Recommended)
 - The switch LEDs are in the normal state.
 - Service ports can forward data properly.

4.2 Logging In to the Management Interface

- (1) Connect a PC to an Ethernet port on the switch through an Ethernet cable.
- (2) Set the IP address of the PC to 10.44.77.XXX (Range: 1–254, excluding 200).

Figure 4-1 Changing the IP Address

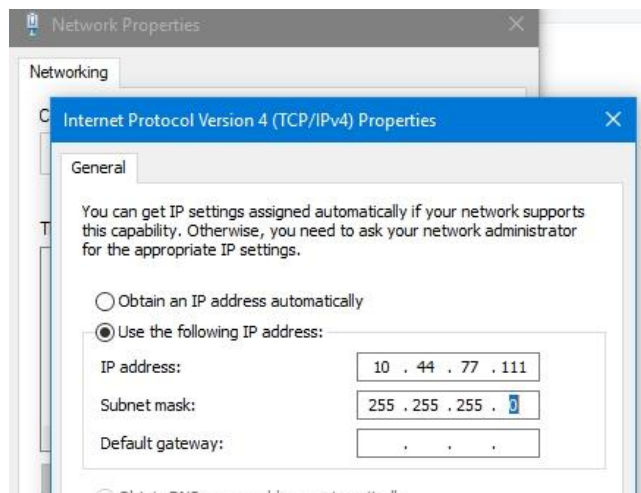

- (3) Open a browser, enter 10.44.77.200 in the address bar, and press Enter. On the login page, set a password and log in.
- (4) Perform equipment commissioning and configuration based on service requirements.

Note

For security purposes, you are advised to change the password regularly.

5 Troubleshooting

5.1 General Troubleshooting Flowchart

Note

You can determine whether each checking item in the process is normal based on the information provided in the previous chapters "Overview" and "Installing the Switch."

Figure 5-1 General Troubleshooting Flowchart

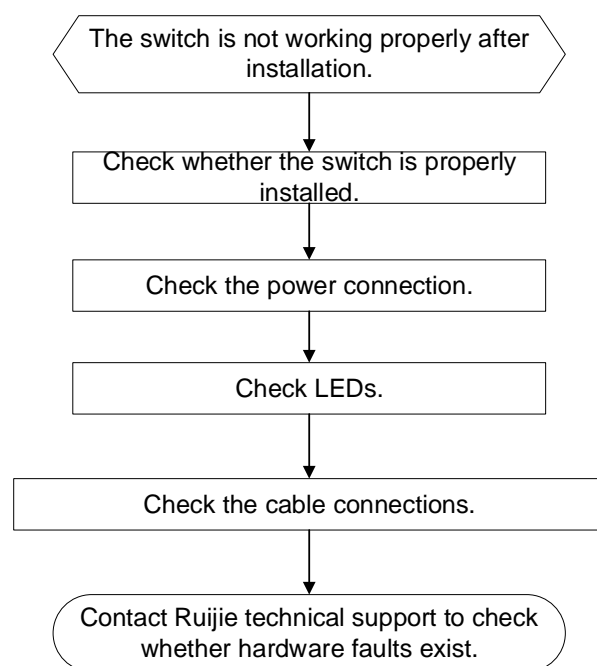

5.2 Common Faults

Table 5-1 Common Faults and Troubleshooting

Symptom	Possible Cause	Suggested Action
The system status LED is off after the switch is powered on.	No power is supplied to the switch or the power cord is loosely connected.	Check whether the power socket in the equipment room is normal and whether the power cord is loosely connected to the switch.
An RJ45 port is disconnected or a frame	The twisted pair is not connected properly.	Replace the twisted pair.

Symptom	Possible Cause	Suggested Action
sending/receiving error occurs.	The cable length exceeds 100 m (328.08 ft.).	Use an optical cable for data transmission or connect to an intermediate switch for relay.
	The port is specially configured and does not work in the same mode as that of the interconnected switch.	Check whether the port is configured to work in the same mode as that of the interconnected switch.
An optical port is not reachable.	The transmit and receive ends are connected incorrectly.	Exchange the transmit and receive ends of the optical cable.
	The types of the interconnected optical transceivers do not match.	Replace with one compatible optical transceiver.
	The optical cable type does not meet the requirements.	Replace the optical cable with a qualified one.
	The optical cable length is beyond the allowed length marked on the optical transceiver.	Use an optical cable with the required length.
	The optical cable or connector is contaminated.	Clean the connector with a lint-free cloth or a cleaning pen.
The login password cannot be retrieved.	The password is forgotten, and the equipment is not connected to the network or Ruijie Cloud.	Press and hold the Reset button to restore to factory settings.
	If the equipment is connected to Ruijie Cloud or a network, its login password is updated to the project or global management password.	If the equipment is connected to the cloud, log in using the project management password. If the equipment is connected to a network, log in using the global management password.
The Ethernet ports are transmitting and receiving frames normally, but their LEDs are off.	<p>The status of the Ethernet port LEDs is incorrectly displayed.</p> <p>The DIP switch is set to LED mode 2. As a result, the Ethernet port LEDs display the PoE status, but PoE is disabled on the ports.</p>	Set the DIP switch to LED mode 1 so that the Ethernet port LEDs display the data receiving and sending status.

6 Appendix

6.1 Connectors and Media

6.1.1 100r100Or1000BASE-T Port

The 10/100/1000BASE-T port supports auto-negotiation for 10 Mbps, 100 Mbps, and 1000 Mbps connections and also supports auto MDI/MDIX Crossover.

Compliant with IEEE 802.3ab, a 1000BASE-T port connects to a 100-ohm Category 5 (CAT5) or Category 5 Enhanced (CAT5e) Unshielded Twisted Pair (UTP), or recommended Shielded Twisted Pair (STP) cable with a maximum distance of 100 m (328.08 ft.).

The 1000BASE-T port requires that all four pairs of wires be connected for data transmission. [Figure 6-1](#) shows twisted pair connections for the 1000BASE-T port.

Figure 6-1 Twisted Pair Connections for a 1000BASE-T Port

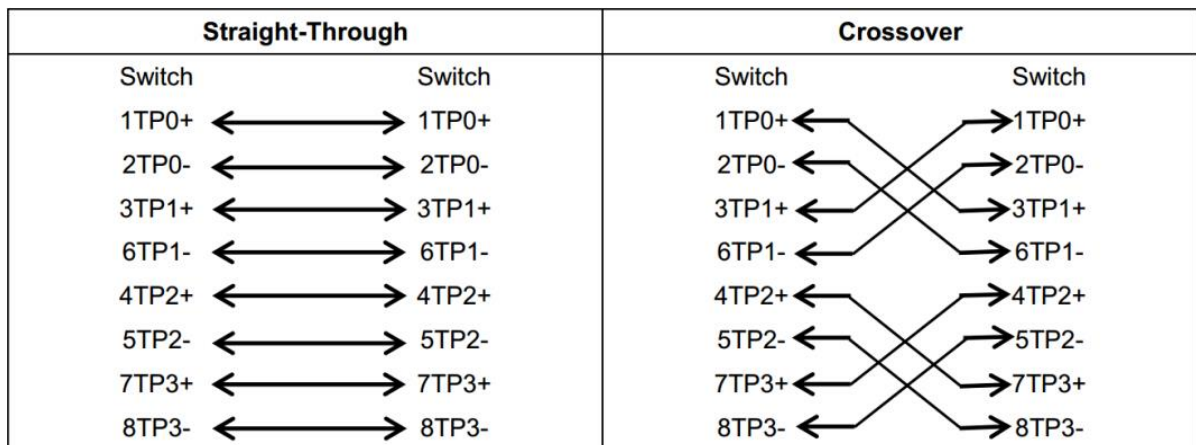

In addition to cables with the above-mentioned specifications, the 10/100BASE-T port can also be connected using 100-ohm CAT3, CAT4, and CAT5 cables at 10 Mbps or using 100-ohm CAT5 cables with a maximum distance of 100 m (328.08 ft.). The following table shows pin assignments for a 10/100BASE-T port.

Table 6-1 10/100BASE-T Pin Assignment

Pin	Socket	Plug
1	Input Receive Data+	Output Transmit Data+
2	Input Receive Data-	Output Transmit Data-
3	Output Transmit Data+	Input Receive Data+
6	Output Transmit Data-	Input Receive Data-
4, 5, 7, and 8	Not Used	Not Used

The following table shows wiring of straight-through and crossover cables for a 10/100BASE-T port.

Figure 6-2 Twisted Pair Connections for a 10/100BASE-T Port

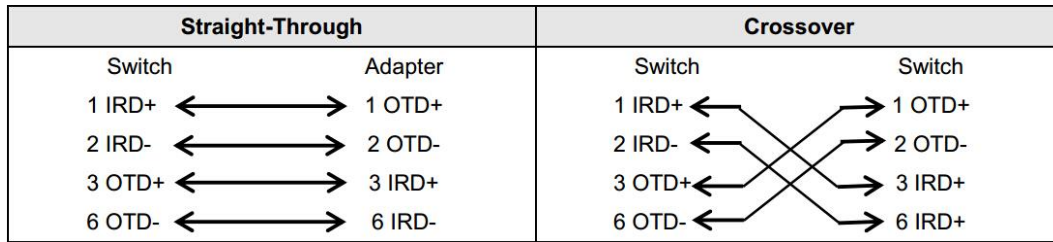

6.1.2 Optical Cable Connection

Select a single-mode fiber (SMF) or multimode fiber (MMF) for connections based on the type of the optical transceiver inserted into an optical port. [Figure 6-3](#) shows the connections.

Figure 6-3 Connecting the Optical Cables

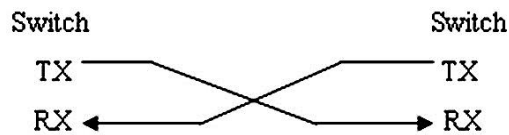

6.2 SFP Transceivers

Ruijie provides SFP transceivers (mini-GBIC) based on the port types. You can select one that suits your specific needs. In addition to the following 1GE SFP transceivers, the 1GE copper transceiver Mini-GBIC-GT is also supported. This document provides models and technical specifications of some 1GE SFP transceivers for reference. For details about the technical specifications, see *Ruijie Transceiver Installation and Reference Guide*.

Table 6-2 1GE Mini-GBIC (SFP) Models and Technical Specifications

Model	Wavelength (nm)	Fiber Type	DDM Supported (Yes/No)	Transmit Power (dBm)		Receive Power (dBm)	
				Min	Max	Min	Max
MINI-GBIC-SX-MM850	850	MMF	Yes	-9	-3	-20	-3
MINI-GBIC-LX-SM1310	1310	SMF	Yes	-9	-3	-26	0
GE-SFP-LH40-SM1310-BIDI	1310TX/1550RX	SMF	Yes	-3	3	-25	0
GE-SFP-LH40-SM1550-BIDI	1550TX/1310RX	SMF	Yes	-3	3	-25	0

GE-SFP-LX20-SM1310-BIDI	1310TX/1550RX	SMF	Yes	-8	-3	-23	-3
GE-SFP-LX20-SM1550-BIDI	1550TX/1310RX	SMF	Yes	-8	-3	-23	-3
MINI-GBIC-LH40-SM1310	1310	SMF	Yes	-5	0	-25	-3
MINI-GBIC-ZX80-SM1550	1550	SMF	Yes	-3	3	-26	-3
GE-SFP-LX03-SM1310-BIDI-I	1310TX/1550RX	SMF	Yes	-9	-3	-22	-3
GE-SFP-LX03-SM1550-BIDI-I	1550TX/1310RX	SMF	Yes	-9	-3	-22	-3
SFP-MM850	850	MMF	Yes	-9.5	-3	-17	-3
SFP-SM1310	1310	SMF	Yes	-9	-3	-20	-3

Table 6-3 1GE SFP Copper Transceivers

Standard	1000BASE-T SFP Module	DDM Supported (Yes/No)
1000BASE-T	Mini-GBIC-GT	No

Table 6-4 Cabling Specifications of SFP Transceivers

SFP Transceiver Model	Port Type	Fiber Type	Core Size (μm)	Max Cabling Distance
SFP-SM1310	LC	SMF	9/125	10 km (6.21 miles)
MINI-GBIC-LX-SM1310	LC	SMF	9/125	10 km (6.21 miles)
GE-SFP-LH40-SM1310-BIDI	LC	SMF	9/125	40 km (24.85 miles)
GE-SFP-LH40-SM1550-BIDI	LC	SMF	9/125	40 km (24.85 miles)
GE-SFP-LX20-SM1310-BIDI	LC	SMF	9/125	20 km (12.43 miles)
GE-SFP-LX20-SM1550-BIDI	LC	SMF	9/125	20 km (12.43 miles)
MINI-GBIC-LH40-SM1310	LC	SMF	9/125	40 km (24.85 miles)

SFP Transceiver Model	Port Type	Fiber Type	Core Size (µm)	Max Cabling Distance
				miles)
MINI-GBIC-ZX80-SM1550	LC	SMF	9/125	80 km (49.71 miles)
GE-SFP-LX03-SM1310-BIDI-I	LC	SMF	9/125	3 km (1.86 miles)
GE-SFP-LX03-SM1550-BIDI-I	LC	SMF	9/125	3 km (1.86 miles)
MINI-GBIC-SX-MM850	LC	MMF	62.5/125	275 m (902.23 ft.)
			50/125	550 m (1,804.46 ft.)
SFP-MM850	LC	MMF	62.5/125	275 m (902.23 ft.)
			50/125	550 m (1,804.46 ft.)
Mini-GBIC-GT	RJ45 Ethernet cable	CAT5 or better UTP or STP cable		100 m (328.08 ft.)

⚠ Caution

- For optical transceivers with a cabling distance of no less than 40 km (24.85 miles), install an optical attenuator to avoid overload on an optical receiver when using short-distance SMFs.
- An optical transceiver is a laser transmitter. Do not look into the light source to prevent it from burning your eyes.
- To keep the optical transceiver clean, make sure that the unused ports remain capped.

Table 6-5 BIDI Optical Transceiver Pairing

Rate/Distance	Pairing Model
1000 Mbps/3 km (1.86 miles)	GE-SFP-LX03-SM1310-BIDI-I GE-SFP-LX03-SM1550-BIDI-I
1000 Mbps/20 km (12.43 miles)	GE-SFP-LX20-SM1310-BIDI GE-SFP-LX20-SM1550-BIDI
1000 Mbps/40 km (24.85 miles)	GE-SFP-LH40-SM1310-BIDI GE-SFP-LH40-SM1550-BIDI

⚠ Caution

BIDI optical transceivers must be used in pairs. For example, if GE-SFP-LX20-SM1310-BIDI is used at one end, GE-SFP-LX20-SM1550-BIDI must be used at the other end.

6.3 Lightning Protection

6.3.1 Installing the AC Power Arrester (Power Strip with Surge Protection)

When an alternating current (AC) power cord is introduced from outdoors and directly connected to the AC power port of the switch, the power port must be connected to an external power arrester to safeguard the switch against lightning strikes. The power arrester can be fixed on the rack, workbench, or wall in the equipment room by using cable ties and screws. AC power enters the power arrester before entering the switch.

Figure 6-4 Power Arrester

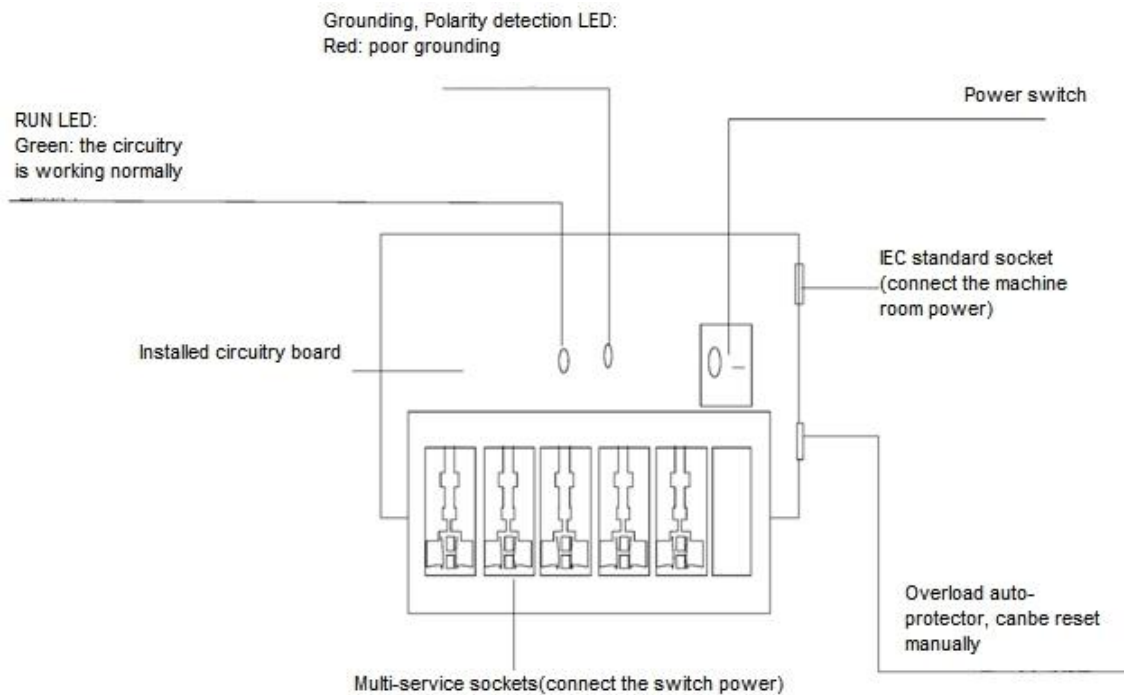

⚠ Caution

The power arrester is not delivered with the equipment. Please purchase it based on actual requirements.

Precautions during the installation:

- Make sure that the PE terminal of the power arrester is well grounded.
- After the AC power plug of the switch is connected to the socket of the power arrester, the lightning protection function is implemented only if the running status LED is green and the alarm LED is off.
- If the alarm LED on the power arrester is red, check whether it is caused by a poor grounding connection or

by the reversed connection of the neutral and live wires. The detection method is as follows: Use a multimeter to measure the polarity of the power arrester when the alarm LED is red. If the neutral wire is on the left and the live wire is on the right (facing the socket), the PE terminal of the power arrester is not grounded. If not, the polarity of the power arrester should be reversed. In this case, open the power arrester and reverse its polarity. If the alarm LED is still red, the PE terminal of the power arrester is not grounded.

6.3.2 Installing the Ethernet Port Arrester

Please connect an Ethernet port arrester to the switch to prevent the damage by lightning strikes before connecting an outdoor Ethernet cable to the switch.

- Tools: Phillips screwdriver or flat-blade screwdriver, multimeter, and diagonal pliers
- Installation steps
 - a Tear one side of the protective paper for the double-sided adhesive tape and paste the tape to the enclosure of the Ethernet port arrester. Tear the other side of the protective paper for the double-sided adhesive tape and paste the Ethernet port arrester to the switch enclosure. The paste position for the Ethernet port arrester should be as close to the grounding lug of the switch as possible.
 - b Based on the distance between the grounding lug of the switch and the Ethernet port arrester, cut the grounding cable of the Ethernet port arrester and firmly tighten the grounding cable to the grounding lug of the switch.
 - c Use a multimeter to check whether the grounding cable for the arrester is in good contact with the grounding lug and the enclosure of the switch.
 - d Connect the Ethernet port arrester by using an adapter cable (note that the external Ethernet cable is connected to the IN end, while the adapter cable connected to the switch is connected to the OUT end) and check whether the module LED is normal.
 - e Use a nylon cable tie to bind the cables.

Figure 6-5 Installing an Ethernet Port Arrester

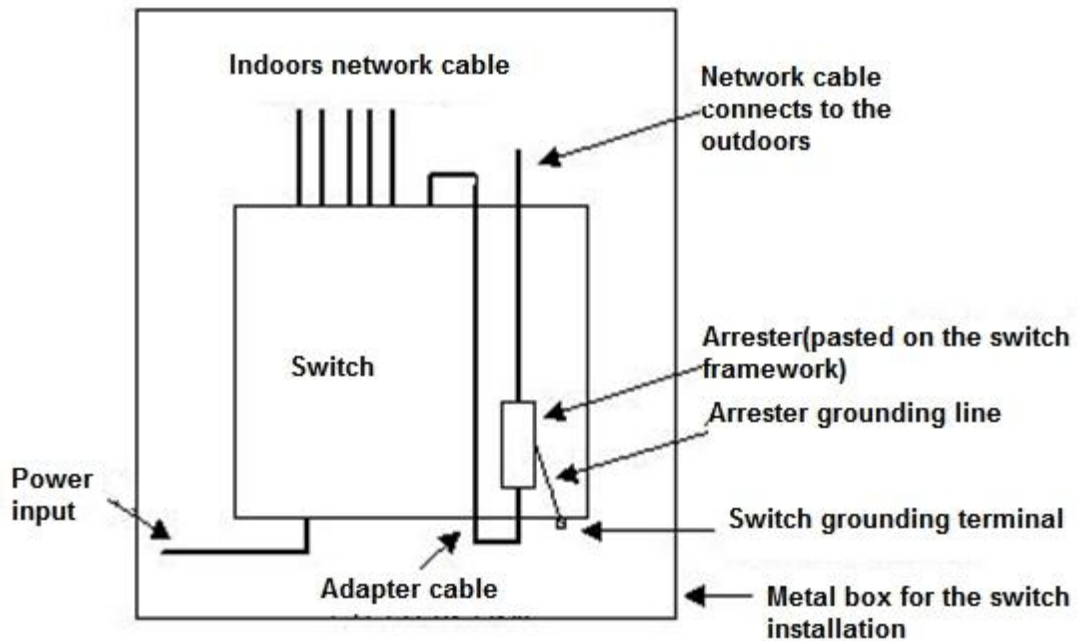

⚠ Caution

- The Ethernet port arrester is only for a 10 Mbps, 100 Mbps, or 1000 Mbps RJ45 port.
- The Ethernet port arrester is not delivered with the equipment. Please purchase it based on actual requirements. The user manual for Ethernet port arresters contains technical parameters and maintenance and installation instructions. Carefully read this manual during installation.

Pay attention to the following situations during the actual installation to avoid influencing the performance of an Ethernet port arrester:

- The arrester is incorrectly connected to the cables. Connect the external Ethernet cable to the IN end and connect the Ethernet port of the switch to the OUT end.
- The Ethernet port arrester is incorrectly grounded. The grounding cable of the arrester should be as short as possible to ensure that it is in good contact with the grounding lug of the switch. Use a multimeter to confirm the contact condition after grounding.
- Not all Ethernet ports are installed with Ethernet port arresters. If outdoor Ethernet cables connect the switch ports to the peer equipment, Ethernet port arresters need to be installed on all the ports for the purpose of lightning protection.

6.4 Recommended Cabling

When the switch is installed in a standard 19-inch cabinet, secure the cables around the cable management brackets. Top cabling or bottom cabling is adopted according to the actual situation in the equipment room. All adapted connectors should be placed at the bottom of the rack in an orderly manner instead of outside the rack that is easy to touch. Power cords are routed beside the rack. Top cabling or bottom cabling is adopted according

to the actual situation in the equipment room, such as the positions of the DC power distribution box, AC socket, or lightning protection box.

6.4.1 Requirement for the Minimum Bend Radius of Cables

- The bend radius of a fixed power cord, Ethernet cable, and flat cable should be over five times greater than their respective external diameters. The bend radius of these cables that are often bent or plugged should be over seven times greater than their respective external diameters.
- The bend radius of a fixed common coaxial cable should be over seven times greater than its external diameter. The bend radius of these cables that are often bent or plugged should be over 10 times greater than their respective external diameters.
- The minimum bend radius of a high-speed cable, such as an SFP+ cable, should be 5 times the overall diameter of the cable. If the cable is constantly bent, plugged or unplugged, the bend radius should be 10 times the overall diameter.
- The minimum bend radius of optical cables should meet the following requirements.
 - The diameter of the optical cable tray should be no less than 25 times greater than that of the optical cable.
 - When an optical cable is moved, its bend radius should be no less than 20 times greater than its diameter.
 - During cabling of an optical cable, its bend radius should be no less than 10 times greater than its diameter.

6.4.2 Precautions for Cable Bundling

- Before cables are bundled, mark labels and stick the labels to cables wherever appropriate.
- Cables should be neatly and properly bundled in the rack without twisting or bending, as shown in [Figure 6-6](#).

Figure 6-6 Bundling Cables (1)

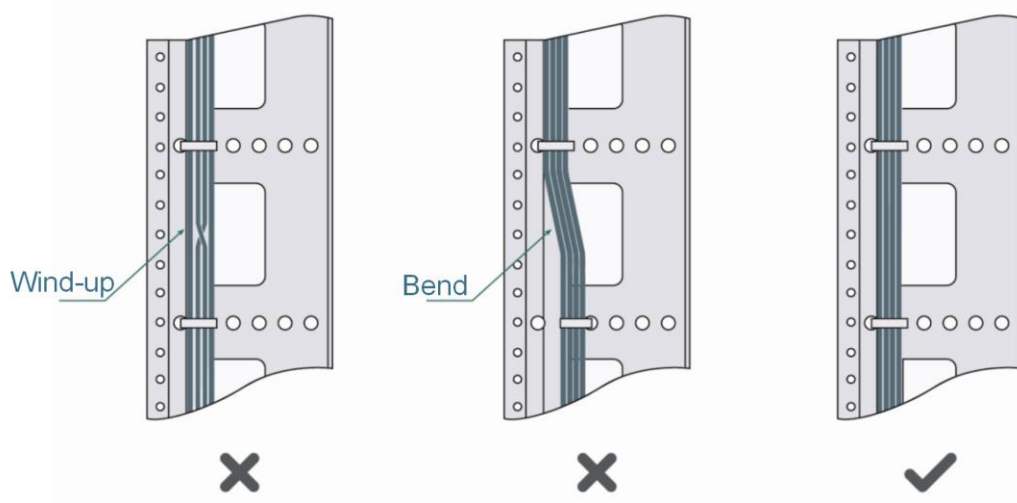

- Cables of different types (such as power cords, signal cables, and grounding wires) should be separated in cabling and bundling. Mixed bundling is not allowed. When they are close to each other, you are advised to

adopt crossover cabling. In the case of parallel cabling, maintain a minimum distance of 30 mm (1.18 in.) between power cords and signal cables.

- The cable management brackets and cabling troughs inside and outside the rack should be smooth without sharp corners.
- The metal holes traversed by cables should have a smooth and fully rounded surface or an insulated lining.
- Use cable ties to bundle cables properly. Please do not connect two or more cable ties to bundle cables.
- After bundling up cables with cable ties, cut off the remaining part. The cut should be smooth and trim without sharp corners, as shown in [Figure 6-7](#).

Figure 6-7 Bundling Cables (2)

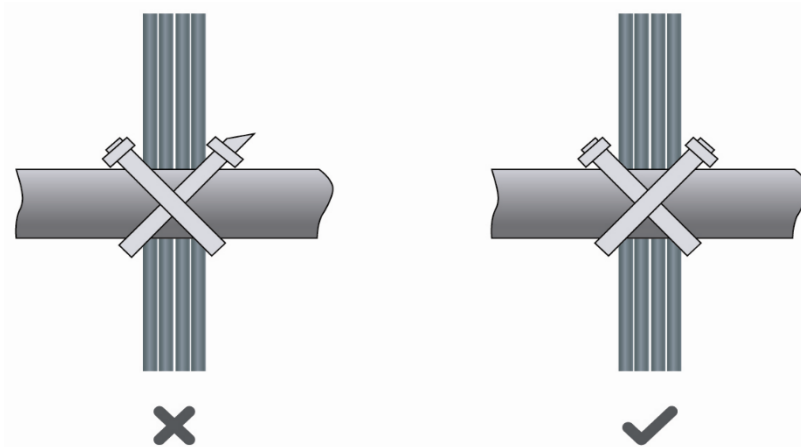

- When cables need to be bent, bundle them first but do not tie cables within the bend. Otherwise, stress may be generated on the cables and cause the wires inside to break, as shown in [Figure 6-8](#).

Figure 6-8 Bundling Cables (3)

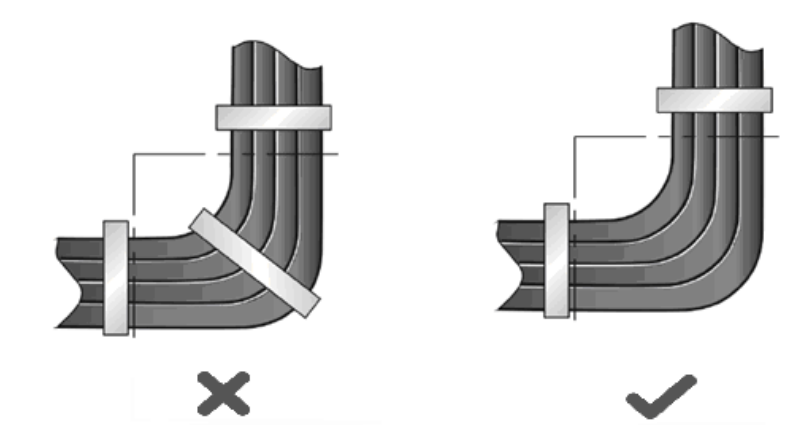

- Cables not to be assembled or the remaining parts of cables should be folded and placed in a proper position of the rack or cable management trough. The proper position refers to a position that does not affect the equipment running or damage the equipment or cables.
- Power cords must not be bundled on the guide rails of moving parts.
- The power cords connecting moving parts such as door grounding wires should be reserved with some

excess after being assembled to avoid suffering tension or stress. When a moving part reaches the installation position, the remaining cable part should not touch heat sources, sharp corners, or sharp edges. If heat sources must be touched, high-temperature cables should be used.

- When using screw threads to secure a cable lug, ensure that the bolt or screw is properly tightened and take measures to prevent it from loosening, as shown in [Figure 6-9](#).

Figure 6-9 Fastening Cables

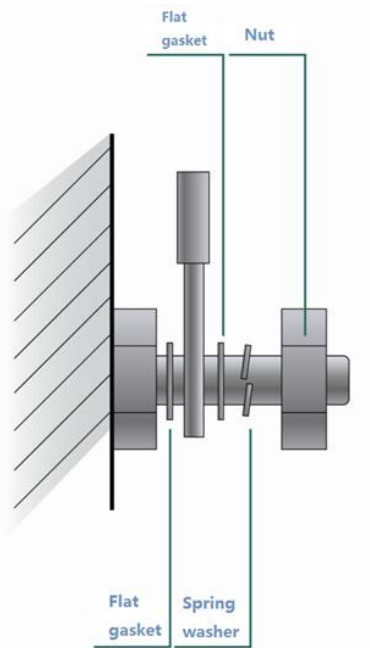

- Hard power cords should be secured near the cable termination area to prevent stress on the cable termination area and cables.
- Do not use tapping screws to secure cable lugs.
- Power cords of the same type and in the same cabling direction should be bundled up into cable bunches, with cables in cable bunches clean and straight.
- Bundle cables by using cable ties according to the following table.

Cable Bunch Diameter	Bundling Spacing
10 mm (0.39 in.)	80–150 mm (3.15–5.91 in.)
10–30 mm (0.39–1.18 in.)	150–200 mm (5.91–7.87 in.)
30 mm (1.18 in.)	200–300 mm (7.87–11.81 in.)

- Do not tie cables or bundles in a knot.
- For wiring terminal blocks (such as circuit breakers) with cord end terminals, the metal part of the cord end terminal should not be exposed outside the terminal block when assembled.

6.5 Site Selection

- The equipment room should be at least 5 km (3.11 miles) away from heavy pollution sources, such as smelters, coal mines, and thermal power plants. The equipment room should be at least 3.7 km (2.30 miles) away from medium pollution sources, such as the chemical factory, rubber factory, and electroplating factory. The equipment room should be at least 2 km (1.24 miles) away from light pollution sources, such as the food factory and leather plant. If the pollution source is unavoidable, the equipment room should be located on the windward side of the pollution source perennially with advanced protection.
- The equipment room should be at least 3.7 km (2.30 miles) away from the sea or salt lake. Otherwise, the equipment room must be sealed, with an air conditioner installed for temperature control. Saline soil cannot be used for construction. Otherwise, you should select equipment with advanced protection against severe environments.
- Do not build the equipment room in the proximity of livestock farms. Otherwise, the equipment room should be located on the windward side of the pollution source perennially. The previous livestock house or fertilizer warehouse cannot be used as the equipment room.
- The equipment room should be firm enough to withstand severe weather conditions such as windstorms, heavy rain, and dense dust. If the dust is unavoidable, keep the door and window away from the pollution source.
- The equipment falls into Class A. Therefore, the equipment room should be located away from the residential area. Otherwise, the equipment room should meet construction specifications to avoid noise and radio interference.
- Make sure the air vent of the equipment room is away from the sewage pipe, septic tank, and sewage treatment tank. Keep the equipment room under positive pressure to prevent corrosive gas from entering the equipment room to corrode components and circuit boards.
- Keep the equipment room away from industrial boilers and heating boilers.
- The equipment room should be on the second floor or higher. Otherwise, the equipment room floor should be 600 mm (23.62 in.) higher than the highest flood level ever recorded.
- Make sure no cracks or holes exist in the wall and floor. If there are cable entries in the wall or window, take proper sealing measures. Ensure that the wall is flat, wear-resistant, and dust-free, meeting standards for flame resistance, soundproofing, heat absorption, dust reduction, and electromagnetic shielding.
- Keep the door and the window closed to make the equipment room sealed.
- You are advised to use the steel door for soundproofing.
- Do not use sulfur-containing materials.
- Keep the air conditioner from blowing wind straight toward the equipment or blowing water drops from the window or air vent toward the equipment.

Contents

1 Overview	4
1.1 About the RG-ES216GC2MS	4
1.2 Equipment Appearance	4
1.2.1 Front Panel.....	4
1.2.2 Rear Panel	5
1.2.3 LEDs	6
1.3 Cooling.....	6
1.4 Technical Specifications	6
2 Preparing for Installation	9
2.1 Package Contents.....	9
2.2 Safety Guidelines.....	9
2.2.1 General Precautions	9
2.2.2 Chassis-Lifting Guidelines	10
2.2.3 Electricity Safety	10
2.2.4 Preventing ESD Damage.....	11
2.2.5 Laser Safety	11
2.3 Site Requirements	12
2.3.1 Floor Loading	12
2.3.2 Airflow.....	12
2.3.3 Space	12
2.3.4 Temperature and Humidity.....	12
2.3.5 Cleanliness.....	12

2.3.6 Grounding	13
2.3.7 Preventing Electromagnetic Interference	14
2.3.8 Surge Protection	14
2.3.9 Installation Site.....	14
2.4 Rack Requirements	14
2.5 Tools	15
3 Installing the Switch	16
3.1 Before You Begin.....	16
3.2 Installing the Switch	16
3.2.1 Rack Mount.....	16
3.2.2 Workbench Mount.....	17
3.3 Grounding the Equipment.....	18
3.4 Connecting Cables.....	19
3.5 Bundling Cables.....	19
3.5.1 Precautions	19
3.5.2 Bundling Procedure	19
3.6 Verifying Installation.....	19
4 Commissioning.....	20
4.1 Power-on.....	20
4.2 Logging In to the Management Interface.....	20
5 Troubleshooting.....	21
5.1 General Troubleshooting Flowchart	21
5.2 Common Faults.....	21
6 Appendix.....	23

6.1 Connectors and Media.....	23
6.1.1 10Or100Or1000BASE-T Port	23
6.1.2 Optical Cable Connection	24
6.2 SFP Transceivers	24
6.3 Lightning Protection	27
6.3.1 Installing the AC Power Arrester (Power Strip with Surge Protection)	27
6.3.2 Installing the Ethernet Port Arrester	28
6.4 Recommended Cabling	29
6.4.1 Requirement for the Minimum Bend Radius of Cables	30
6.4.2 Precautions for Cable Bundling	30
6.5 Site Selection	33

1 Overview

1.1 About the RG-ES216GC2MS

The RG-ES216GC2MS Ethernet switch provides 16 10/100/1000BASE-T ports, two 1GE/2.5GE SFP ports, one Reset button, and several LEDs on the front panel, along with an AC power port and a grounding stud on the rear panel.

Figure 1-1 RG-ES216GC2MS Appearance



Note

- 2.5GE SFP port: Supports 2.5GE and 1GE SFP optical transceivers (not compatible with 100 Mbps optical cables).
- 10/100/1000BASE-T port: Supports auto-negotiation at 10 Mbps, 100 Mbps, and 1000 Mbps.

1.2 Equipment Appearance

1.2.1 Front Panel

Figure 1-2 Front Panel of the RG-ES216GC2MS

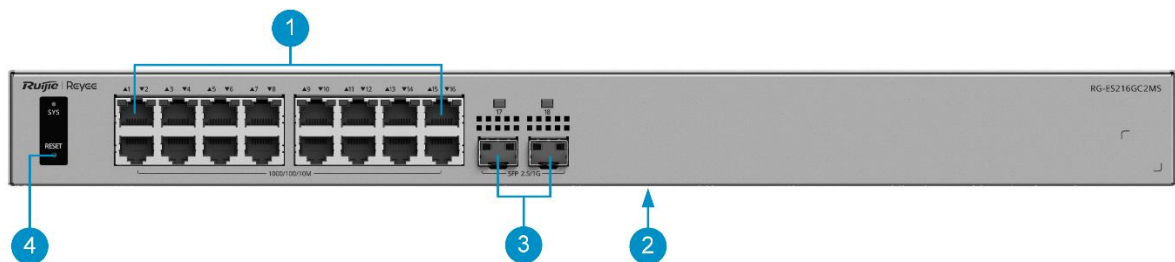

Table 1-1 Components on the Front Panel

No.	Component	Silkscreen	Description
1	RJ45 port	1000/100/10M	10/100/1000BASE-T ports

No.	Component	Silkscreen	Description
2	Nameplate	-	It is located at the bottom of the switch.
3	SFP port	SFP 2.5/1G	1GE/2.5GE SFP port, supporting 1GE/2.5GE SFP transceiver (hot-swappable)
4	Reset button	RESET	<ul style="list-style-type: none"> ● Press and hold the button for less than 2 seconds. The switch is reset. ● Press and hold the button for 2–5 seconds. No action is performed. ● Press and hold the button for more than 5 seconds, and release the button until the system status LED starts blinking to restore factory settings and restart the switch.

Note

For details about LEDs on the front panel, see "LEDs."

1.2.2 Rear Panel

Figure 1-3 Rear Panel of the RG-ES216GC2MS



Table 1-2 Components on the Rear Panel

No.	Component	Description
1	Power cable spring clip hole	Secures the power cord retention clip to the holes.
2	Power port	Indicates a three-pin power port used for AC power connection.
3	Ventilation openings	Used for heat dissipation of the switch.
4	Grounding stud	Used to connect the switch to the ground.

1.2.3 LEDs

Figure 1-4 RG-ES216GC2MS LEDs

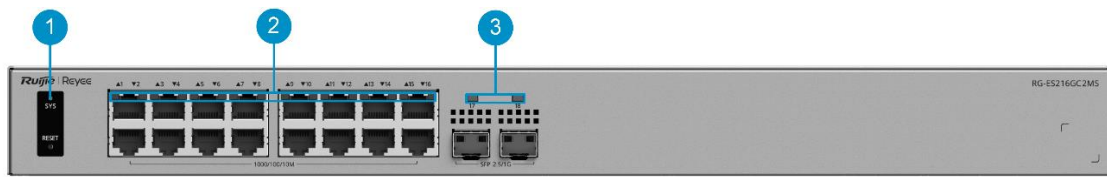

Table 1-3 LEDs

No.	Component	Silkscreen	Description
1	System status LED	SYS	<ul style="list-style-type: none"> Off: The switch is not powered on. Slow blinking green (0.5 Hz): The switch is operating normally but is not connected to Ruijie Cloud. Fast blinking green (10 Hz): The switch is upgrading or restarting, and is temporarily unavailable. Solid green: The switch is operating normally and connected to Ruijie Cloud. Slow blinking red (0.5 Hz): A loop occurs on the switch with loop guard enabled.
2	RJ45 port LED	1–16	<ul style="list-style-type: none"> Off: The port is not connected. Solid green: The port is operating at 1000 Mbps, 100 Mbps, or 10 Mbps, but is not receiving or sending data. Blinking green: The port is operating at 1000 Mbps, 100 Mbps, or 10 Mbps, and is receiving or sending data.
3	SFP port LED	17, 18	<ul style="list-style-type: none"> Off: The port is not connected. Solid green: The port is operating at 1000 Mbps or 2500 Mbps, but is not receiving or sending data. Blinking green: The port is operating at 1000 Mbps or 2500 Mbps, and is receiving or sending data.

1.3 Cooling

The RG-ES216GC2MS adopts fanless design and uses natural cooling. To ensure that the equipment works properly in the specified environment, a minimum clearance of 10 cm (3.94 in.) must be maintained around the equipment for air circulation and ventilation.

1.4 Technical Specifications

! Warning

- This equipment is not suitable for use in locations where children are likely to be present.
- Operation of this equipment in a residential environment could cause radio interference.

Table 1-4 Technical Specifications

Parameter Type	Parameter Name	RG-ES216GC2MS
System Specifications	Forwarding rate	31.25 Mpps
	Switching capacity	42 Gbps(bit/s)
	Flash memory	8 MB
Port Specifications	Total number of optical ports	2
	Total number of RJ45 ports	16
	Number of 10/100/1000BASE-T ports	16
	Reset button	1
	LEDs	1 x system status LED 16 x Ethernet port LEDs 2 x SFP port LEDs
Power Supply and Consumption	Power supply	Fixed power supply
	Power input	220 V AC power supply: <ul style="list-style-type: none"> ● Rated input voltage: 100 V AC to 240 V AC, 50 Hz to 60 Hz ● Maximum input voltage: 90 V AC to 264 V AC, 47 Hz to 63 Hz ● Rated input current: 0.6 A
	Maximum power consumption	13 W
Dimensions and Weight	Product dimensions (W x D x H)	440 mm x 165 mm x 44 mm (17.32 in. x 6.50 in. x 1.73 in.)
	Weight	1.66 kg (3.66 lbs) (without packaging materials)
	Shipping weight	2.51kg (5.53 lbs)
	Casing	Metal
Interface	EEE	Yes
	Mounting options	Rack/Desk

Parameter Type	Parameter Name	RG-ES216GC2MS
Environment and Reliability	Hot swapping of cables	Hot swapping supported by the service port and power connector
	Fan	Fanless design
	Cooling	Natural cooling
	MTBF	200,000 hours
	ESD protection	Air discharge: 8 kV Contact discharge: 6 kV
	Surge protection	Service port: ± 6 kV for common mode Power connector: ± 6 kV for common mode and ± 6 kV for differential mode
	Operating temperature	0°C to 40°C (32°F to 104°F)
	Storage temperature	-40°C to +70°C (-40°F to +158°F)
	Operating humidity	10% RH to 90% RH (non-condensing)
	Storage humidity	5% RH to 95% RH (non-condensing)
	Altitude	-500 m to +5,000 m (-1,640.42 ft. to +16,404.20 ft.)
Certification and Regulatory Compliance	EMC	EN 55032 EN 61000-3-2 EN 61000-3-3 EN 55035 EN 300 386
	Safety compliance	EN 62368-1 IEC 62368-1
	Certification	CE, CB

2 Preparing for Installation

2.1 Package Contents

Table 2-1 Package Contents

No.	Item	Quantity
1	RG-ES216GC2MS switch	1
2	Rubber pad	4
3	User Manual	1
4	Warranty Card	1
5	M4 x 8 mm cross recessed countersunk head screw	6
6	Rack-mount bracket	2
7	Power cord retention clip	1
8	Power cord	1

Note

The package contents are subject to the purchase contract, and actual delivery may vary. Please check the items carefully against the package contents or purchase contract. If you have any questions, please contact the distributor.

2.2 Safety Guidelines

Note

- To avoid personal injury or equipment damage, review the safety guidelines in this chapter before you begin the installation.
- The following safety guidelines may not include all the potentially hazardous situations.

2.2.1 General Precautions

- Install the equipment in a standard 19-inch rack and ensure that the rack and power distribution system are properly grounded.
- Never operate the equipment in a wet environment, and avoid any liquids inside it. Keep the chassis clean and dust-free.
- Keep the equipment away from heat sources.
- Keep the equipment away from walk areas.
- During installation and maintenance, do not wear loose clothing or ornament that may get caught in the

chassis.

- Keep tools and accessories away from walk areas.

2.2.2 Chassis-Lifting Guidelines

- Avoid moving the equipment frequently.
- Turn off all power supplies and disconnect all cables before lifting or moving the equipment.
- Two or more people are required to lift the chassis. Keep balance and prevent personal injuries when lifting or moving the equipment.

2.2.3 Electricity Safety

Warning

- Any deviation from standard or improper electrical operations can result in accidents such as fires or electric shocks, potentially causing severe or even fatal harm to both individuals and equipment.
 - Direct or indirect touch through a wet object on high-voltage and mains supply can bring a fatal danger.
-
- Always observe the local regulations and standards. Only qualified personnel should be allowed to operate the equipment.
 - Carefully check the work area for potential hazards, including ungrounded power system, absent safety grounds, and damp floors.
 - Locate the emergency power-off switch in the room before installation. In the case of an accident, cut off the power supply immediately.
 - Never assume that power is connected to or disconnected from a circuit. Always check.
 - Select the right leakage protector (also called "leakage current switch" or "leakage current breaker") for the power supply system. This equipment automatically disconnects the power supply in the event of leakage and the risk of electric shock. A leakage protector should meet the following requirements:
 - The rated leakage action current of each leakage protector must be at least twice the total maximum leakage current of all connected power supplies.
Example:
If a system has 16 identical power supplies, each with a maximum leakage current of 3.5 mA:
Total leakage current = 16 x 3.5 mA = 56 mA
For a 30 mA leakage protector:
Maximum number of power supplies per protector = 30 mA/2/3.5 mA ≈ 4
Therefore, only four power supplies can be connected to one 30 mA leakage protector.
To support 16 power supplies, at least four 30 mA leakage protectors are required.
Always ensure:
Rated leakage operating current/2 > Total maximum leakage current of connected power supplies
 - The rated leakage non-action current of a leakage protector should be 50% of the leakage action current. If the non-action current value is too small, the high sensitivity level can cause the circuit to break, leading to power cutoff and service interruption, even if the leakage current value is normal.
-

For example, if a leakage protector has a rated leakage action current of 30 mA, the rated leakage non-action current should be 15 mA. The leakage protector will not activate unless the leakage current exceeds 15 mA.

⚠ Caution

- To ensure personal safety, each leakage protector in the system must have a rated leakage action current equal to or below 30 mA, which is the recognized safety threshold for human body current. If the total leakage current of the system exceeds twice the 30 mA limit, the system must be equipped with two or more leakage protectors to maintain safety.
 - The leakage current values vary with equipment. For the leakage current value of each equipment model, see "Technical Specifications."
-

2.2.4 Preventing ESD Damage

- Ensure that the chassis is connected to earth ground.
- Keep the site as dust free as possible.
- Maintain appropriate humidity conditions.
- Before installing any pluggable modules, wear an anti-ESD wrist strap and make sure that it is properly grounded.
- Avoid contact between the printed circuit boards and clothing. The anti-ESD wrist strap only protects the printed circuit boards from ESD voltages on the body. ESD voltages on clothing can still cause damage.

2.2.5 Laser Safety

The equipment supports various types of optical transceivers, which are Class 1 laser products.

Precautions:

- When an optical transceiver is working, ensure that its port is connected to an optical cable or covered by a dust cap to keep out dust and prevent it from burning your eyes.
- Do not stare into an optical port.

Figure 2-1 Laser Product ID

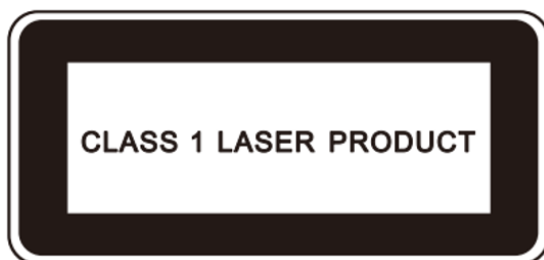

⚠ Caution

Do not approach or stare into an optical port under any circumstances. This may cause permanent damage to your eyes.

2.3 Site Requirements

The equipment must be installed indoors for normal operation and prolonged service life.

The installation site must meet the following requirements.

2.3.1 Floor Loading

Assess the combined weight of the equipment and its accessories, such as rack, chassis, and power modules, and verify that the floor under the rack can bear the weight.

2.3.2 Airflow

The equipment adopts natural cooling. Reserve a sufficient clearance around the equipment to ensure proper ventilation.

2.3.3 Space

You are advised to have a pathway of at least 0.8 m (2.62 ft.) wide in the equipment room. This space ensures that you can move the chassis and swap the modules easily.

Do not install the equipment against a wall. Instead, maintain a minimum clearance of 10 cm (3.94 in.) around the equipment for heat dissipation and equipment maintenance.

2.3.4 Temperature and Humidity

To ensure the normal operation and a prolonged service life of the equipment, maintain an appropriate temperature and humidity in the installation environment.

Prolonged exposure to inappropriate temperature and humidity conditions can cause damage to the equipment.

- In an environment with high relative humidity, insulating materials are prone to poor insulation or even electricity leakage.
- In an environment with low relative humidity, insulating gaskets may shrink, resulting in screw loosening.
- In a dry environment, static electricity is more likely to occur, posing a risk to the internal circuits of equipment.
- A high temperature can accelerate the aging process of insulation materials, greatly reducing the availability of the equipment and severely affecting its service life.

2.3.5 Cleanliness

Dust poses a significant hazard to the equipment. Dust on the enclosure causes electrostatic adhesion, leading to poor contact of the metallic joints. Electrostatic adhesion is more likely to occur in an indoor environment with relatively low humidity, not only affecting the service life of the equipment, but also causing communication faults.

The following table lists the requirements for dust concentration and particle size in the equipment room.

Table 2-2 Requirements for Dust

Particle Diameter	Unit	Concentration
≥ 0.5 μm	Particles/m ³	≤ 3.5 × 10 ⁶
≥ 5 μm	Particles/m ³	≤ 3.5 × 10 ⁶

Apart from dust, there are also requirements on the salt, acid, and sulfide in the air of the equipment room. These harmful substances will accelerate metal corrosion and component aging. Therefore, the equipment room should be properly protected against harmful gases, such as sulfur dioxide, hydrogen sulfide, nitrogen dioxide, and chlorine gas. The following table lists the limits on harmful gases.

Table 2-3 Requirements for Gases

Gas	Average (mg/m ³)	Maximum (mg/m ³)
Sulfur dioxide (SO ₂)	0.3	1.0
Hydrogen sulfide (H ₂ S)	0.1	0.5
Nitrogen dioxide (NO ₂)	0.5	1.0
Chlorine gas (Cl ₂)	0.1	0.3

 **Note**

Average refers to the average value of harmful gases measured in a week. **Maximum** refers to the upper limit of harmful gases measured in a week for up to 30 minutes every day.

2.3.6 Grounding

A proper grounding system is crucial for ensuring stable and reliable operation, as well as preventing lightning strikes and interference. Carefully check the grounding conditions at the installation site according to the grounding requirements, and complete grounding properly based on the site situation.

- Safety Grounding

Ensure that the rack and power distribution system are securely grounded if the equipment uses the AC power supply. Otherwise, electric shocks may occur when the insulation resistance between the power module and the chassis decreases.

 **Caution**

- The building should provide a protective ground connection to ensure that the equipment is connected to a protective ground.
 - Verify that the AC socket is reliably connected to the protective grounding system of the building. If not, a protective grounding wire should be used to connect the protective grounding lug of the AC socket to the protective grounding system of the building.
-

- Lightning Grounding

The lightning protection system is an independent system composed of a lightning rod, a downlead conductor, and a connector connected to the grounding system. The grounding system is typically used for power reference grounding and safety grounding of the rack. Lightning grounding is required only for facilities, and is not required for the equipment.

- EMC Grounding

Electromagnetic compatibility (EMC) grounding includes shielded grounding, filter grounding, noise and interference suppression, and level reference.

2.3.7 Preventing Electromagnetic Interference

- Take interference prevention measures for the power supply system.
- Keep the equipment away from the grounding system or lightning protection grounding system of the power facility.
- Keep the equipment far away from high-frequency current equipment such as high-power radio transmitting stations and radar launchers.
- Take electromagnetic shielding measures when necessary.

2.3.8 Surge Protection

Although the equipment can guard against lightning strikes, strong lightning strikes may still damage the equipment. Take the following surge protection measures:

- Ensure that the grounding wire of the rack is in good contact with the ground.
- Ensure that the neutral point of the AC power socket is in good contact with the ground.
- Install a power arrester in front of the power input end to enhance surge protection for the power supply.

2.3.9 Installation Site

Regardless of whether the equipment is installed in a rack or on a workbench, ensure that the following conditions are met:

- Maintain a proper clearance around the air inlets and outlets for heat dissipation.
- Install the equipment in a standard 19-inch rack. Alternatively, place the equipment on a clean workbench. The installation of air conditioners is recommended in hot areas.
- The installation site has a good cooling and ventilation system.
- The installation site is sturdy enough to support the weight of the chassis and its accessories.
- The installation site is properly grounded.

2.4 Rack Requirements

If you plan to install the equipment in a rack, ensure that the rack meets the following conditions.

- (1) Use a four-post 19-inch rack.
- (2) The left and right square-hole rack posts are 465 mm (18.31 in.) apart.

Figure 2-2 19-Inch Rack

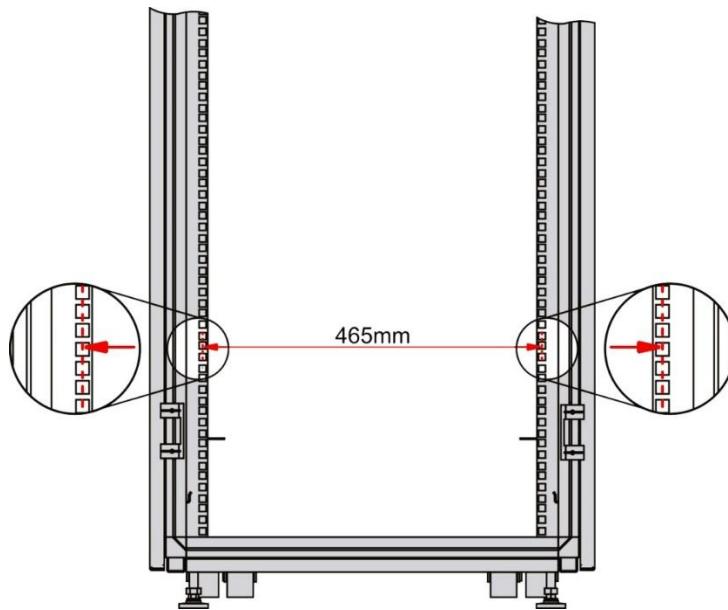

- (3) The square-hole rack post is at least 180 mm (7.09 in.) from the front door, and the front door is at most 25 mm (0.98 in.) thick. This ensures an available clearance of at least 155 mm (6.10 in.). The rack depth (distance between front and rear doors) is at least 1000 mm (39.37 in.).
- (4) The guide rails or tray can bear the weight of the equipment and its accessories.
- (5) The rack has a reliable grounding lug for the chassis to connect to earth ground.
- (6) The rack has a reliable ventilation system. The open area of front and rear doors is greater than 50%.

2.5 Tools

Table 2-4 Tools

Common Tools	Phillips screwdriver, cables, cage nuts, diagonal pliers, cable ties, and grounding wires
Dedicated Tools	Anti-ESD gloves, wire stripper, crimping pliers, RJ45 crimping pliers, and wire cutter
Meter	Multimeter

Note

The equipment is delivered without a toolkit. Prepare the preceding tools by yourself.

3 Installing the Switch

Caution

Before installing the equipment, ensure that guidelines and requirements in Chapter 2 have been met.

3.1 Before You Begin

- The installation site provides sufficient space for heat dissipation.
- The installation site meets the temperature and humidity requirements.
- The power supply is available at the installation site, and its current meets the requirements.
- The Ethernet cables have been deployed at the installation site.
- Locate the emergency power-off switch in the room before installation. In the case of an accident, cut off the power supply immediately.

3.2 Installing the Switch

3.2.1 Rack Mount

Install the RG-ES216GC2MS switch in a standard 19-inch rack. The installation steps are as follows:

- (1) Take out the M4 x 8 mm cross recessed countersunk head screws delivered with the switch. Attach a rack-mount bracket to each side of the switch and secure it with three screws.

Figure 3-1 Securing Rack-Mount Brackets

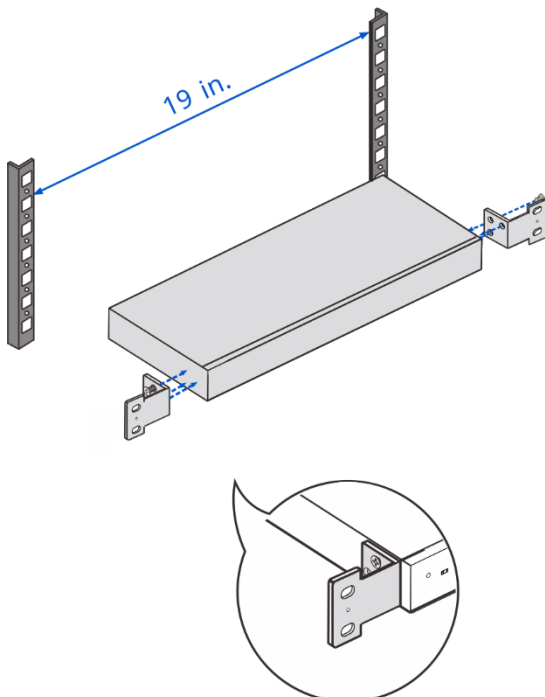

- (2) Horizontally position the switch at the desired location in the rack, and secure the other end of the rack-mount brackets to front square holes of the rack using four M6 screws and four cage nuts.

Figure 3-2 Installing the Switch in a Rack

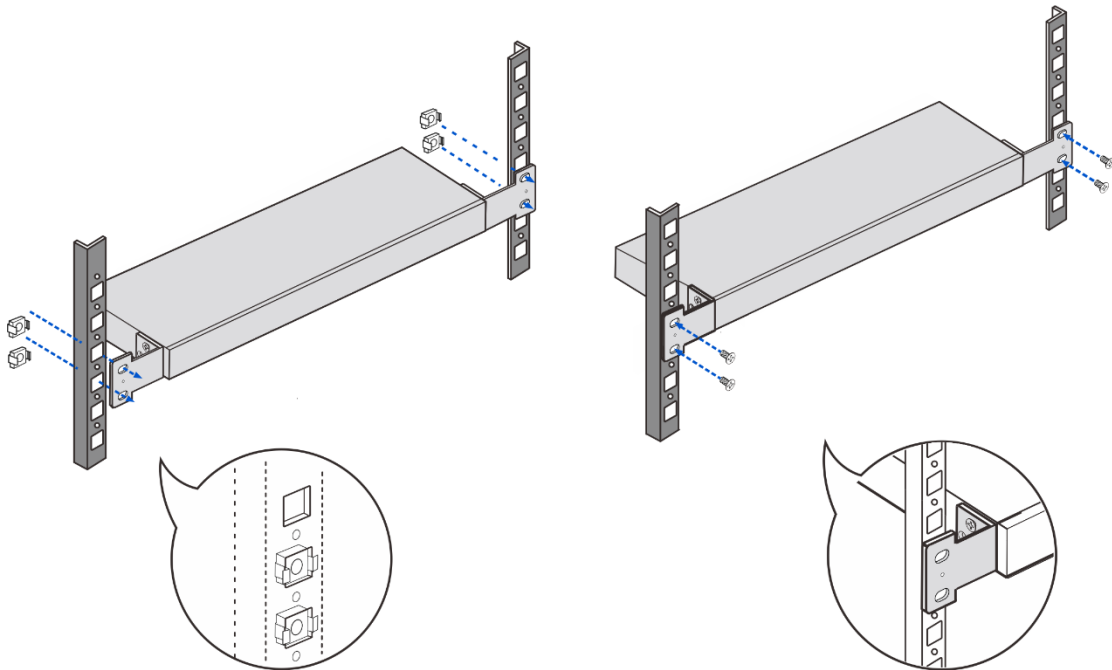

3.2.2 Workbench Mount

In most cases, users do not have a standard rack, and equipment can be placed on a clean workbench. The installation process is as follows:

- (1) Attach the four rubber pads in the package to the dents at the four corners on the bottom of the switch.

Figure 3-3 Attaching the Rubber Pads

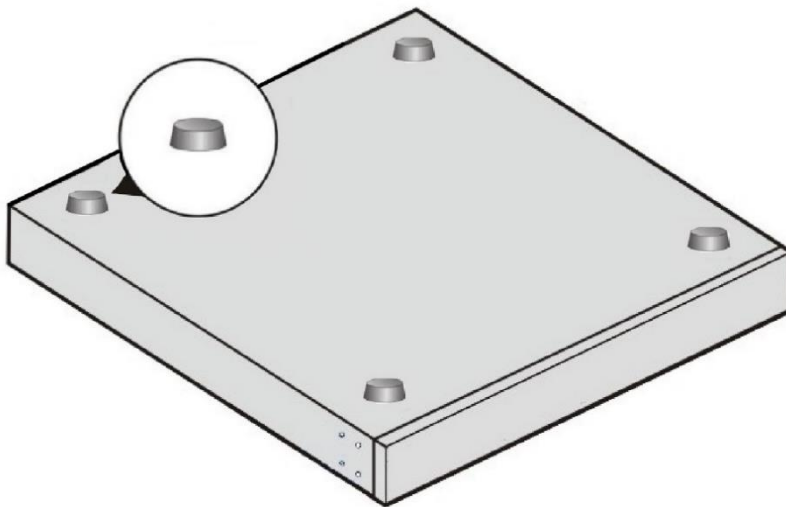

- (2) Place the equipment on a workbench.

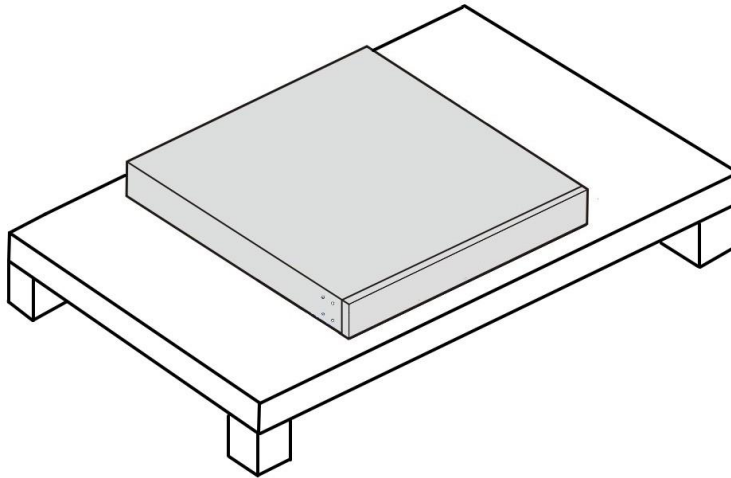
Figure 3-4 Placing the Equipment on a Workbench

3.3 Grounding the Equipment

Note

- If the equipment is installed on a workbench, connect the grounding wire to the nearest grounding bar or grounding point based on the onsite situation.
 - The grounding wire is not delivered with the equipment and needs to be purchased by the customer.
-

The equipment has a grounding stud on the rear panel. You are advised to connect the system grounding wire to it before using the equipment.

- (1) Purchase a grounding wire and connect one end to the grounding stud at the rear of the equipment.
- (2) Connect the other end to the grounding lug of the rack. Ensure the grounding lug of the rack has been connected to the grounding bar.

Caution

- To avoid personal injury and equipment damage, connect the switch to earth ground properly. The grounding resistance between the chassis and the ground should be less than 1 ohm.
 - The O&M personnel should verify whether the AC socket is reliably connected to the protective ground of the building. If not, the O&M personnel should use a protective grounding wire to connect the protective grounding lug of the AC socket to the protective ground of the building.
 - The power socket should be installed near the equipment and easily accessible.
 - During the equipment installation, connect the grounding wire first and disconnect it last.
 - The sectional area of a grounding wire should be determined according to the possible maximum current. Grounding wires with good conductors should be used.
 - Do not use bare wires.
-

3.4 Connecting Cables

Caution

- All cables must be routed indoors. Take surge protection measures if they need to be routed outdoors.
 - When connecting an optical cable, connect the transmit (TX) port on the local equipment to the receive (RX) port on the peer equipment, and vice versa.
-

After the switch is installed, connect the switch to other equipment according to the following steps:

- (1) Connect the power cord delivered with the switch to the power strip.
- (2) Connect the RJ45 connector of a twisted pair to an Ethernet port on the switch, and the other end to downlink equipment.
- (3) Insert an optical transceiver into the optical port first according to the panel identification. Then connect a single-mode fiber (SMF) or multimode fiber (MMF) to the corresponding optical transceiver, during which the transmitting and receiving ends of the optical cable should be distinguished.

3.5 Bundling Cables

3.5.1 Precautions

- Bundle the power cord and other cables in an esthetically pleasing way.
- Make sure that the optical cables at the connectors have natural bends or bends of large radius.
- Do not bind optical cables and twisted pairs too tightly, as this may press the cables and affect their service life and transmission performance.

3.5.2 Bundling Procedure

- (1) Bind the drooping part of the optical cables and twisted pairs, and lead them to both sides of the chassis for convenience.
- (2) On both sides of the chassis, fasten the optical cables and twisted pairs to the cable management ring or cabling chute.
- (3) Bind the power cord closely along the bottom of the chassis, in a straight line wherever possible.

3.6 Verifying Installation

Caution

Please turn off the power to avoid personal injury and damage to components caused by incorrect connection.

- Verify that the grounding wire is connected.
- Verify that the cables including power cords are properly connected.
- Verify that cables connected to ports are routed indoors.
- Verify that the surge protection socket and Ethernet port arrester are installed, if outdoor cabling exists.
- Verify that there is a minimum clearance of 10 cm (3.94 in.) around the switch.

4 Commissioning

4.1 Power-on

- (1) Checklist Before Power-on
 - The switch is properly grounded.
 - The power cord is properly connected.
 - The power supply voltage meets the requirement of the switch.
- (2) Checklist After Power-on (Recommended)
 - The switch LEDs are in the normal state.
 - Service ports can forward data properly.

4.2 Logging In to the Management Interface

- (1) Connect a PC to an Ethernet port on the switch through an Ethernet cable.
- (2) Set the IP address of the PC to 10.44.77.XXX (Range: 1–254, excluding 200).

Figure 4-1 Changing the IP Address

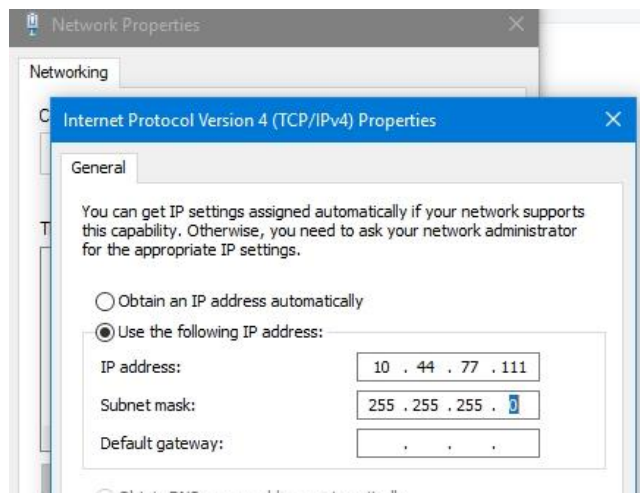

- (3) Open a browser, enter 10.44.77.200 in the address bar, and press Enter. On the login page, set a password and log in.
- (4) Perform equipment commissioning and configuration based on service requirements.

Note

For security purposes, you are advised to change the password regularly.

5 Troubleshooting

5.1 General Troubleshooting Flowchart

Note

You can determine whether each checking item in the process is normal based on the information provided in the previous chapters "Overview" and "Installing the Switch."

Figure 5-1 General Troubleshooting Flowchart

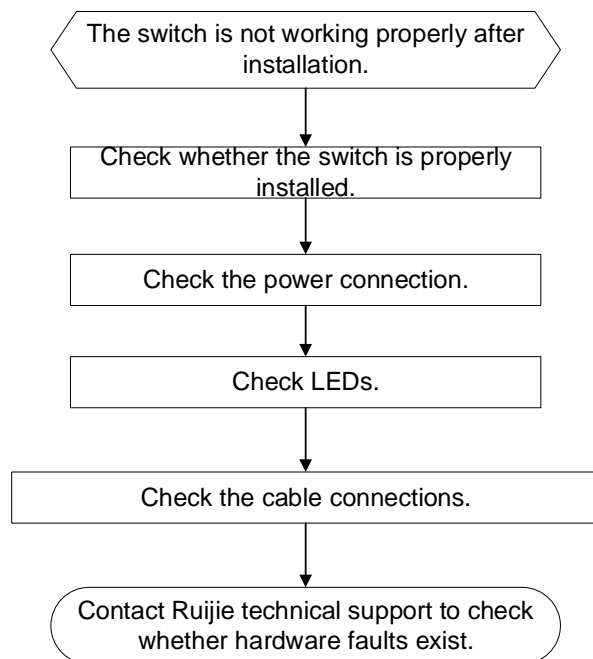

5.2 Common Faults

Table 5-1 Common Faults and Troubleshooting

Symptom	Possible Cause	Suggested Action
The system status LED is off after the switch is powered on.	No power is supplied to the switch or the power cord is loosely connected.	Check whether the power socket in the equipment room is normal and whether the power cord is loosely connected to the switch.
An RJ45 port is disconnected or a frame	The twisted pair is not connected properly.	Replace the twisted pair.

Symptom	Possible Cause	Suggested Action
sending/receiving error occurs.	The cable length exceeds 100 m (328.08 ft.).	Use an optical cable for data transmission or connect to an intermediate switch for relay.
	The port is specially configured and does not work in the same mode as that of the interconnected switch.	Check whether the port is configured to work in the same mode as that of the interconnected switch.
An optical port is not reachable.	The transmit and receive ends are connected incorrectly.	Exchange the transmit and receive ends of the optical cable.
	The types of the interconnected optical transceivers do not match.	Replace with one compatible optical transceiver.
	The optical cable type does not meet the requirements.	Replace the optical cable with a qualified one.
	The optical cable length is beyond the allowed length marked on the optical transceiver.	Use an optical cable with the required length.
	The optical cable or connector is contaminated.	Clean the connector with a lint-free cloth or a cleaning pen.
The login password cannot be retrieved.	The password is forgotten, and the equipment is not connected to the network or Ruijie Cloud.	Press and hold the Reset button to restore to factory settings.
	If the equipment is connected to Ruijie Cloud or a network, its login password is updated to the project or global management password.	If the equipment is connected to the cloud, log in using the project management password. If the equipment is connected to a network, log in using the global management password.

6 Appendix

6.1 Connectors and Media

6.1.1 100r100Or1000BASE-T Port

The 10/100/1000BASE-T port supports auto-negotiation for 10 Mbps, 100 Mbps, and 1000 Mbps connections and also supports auto MDI/MDIX Crossover.

Compliant with IEEE 802.3ab, a 1000BASE-T port connects to a 100-ohm Category 5 (CAT5) or Category 5 Enhanced (CAT5e) Unshielded Twisted Pair (UTP), or recommended Shielded Twisted Pair (STP) cable with a maximum distance of 100 m (328.08 ft.).

The 1000BASE-T port requires that all four pairs of wires be connected for data transmission. [Figure 6-1](#) shows twisted pair connections for the 1000BASE-T port.

Figure 6-1 Twisted Pair Connections for a 1000BASE-T Port

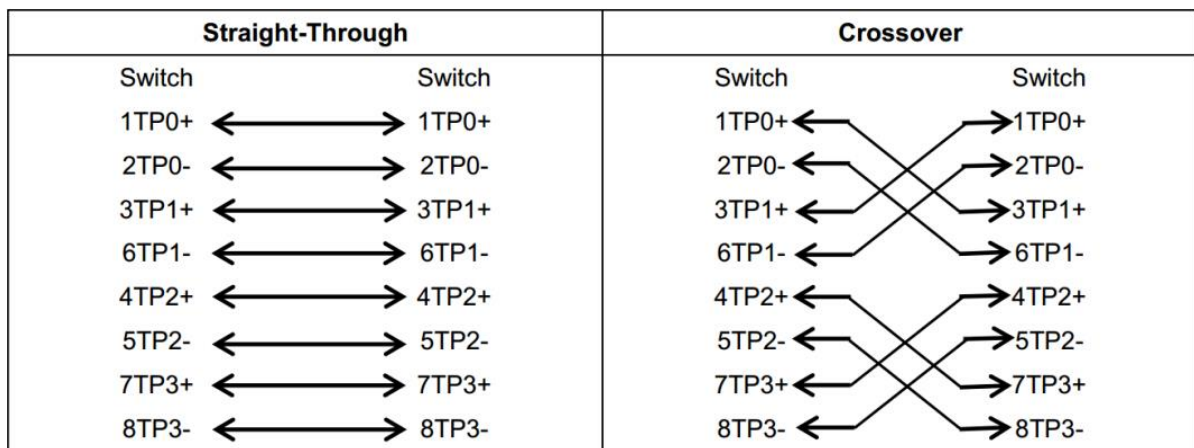

In addition to cables with the above-mentioned specifications, the 10/100BASE-T port can also be connected using 100-ohm CAT3, CAT4, and CAT5 cables at 10 Mbps or using 100-ohm CAT5 cables with a maximum distance of 100 m (328.08 ft.). The following table shows pin assignments for a 10/100BASE-T port.

Table 6-1 10/100BASE-T Pin Assignment

Pin	Socket	Plug
1	Input Receive Data+	Output Transmit Data+
2	Input Receive Data-	Output Transmit Data-
3	Output Transmit Data+	Input Receive Data+
6	Output Transmit Data-	Input Receive Data-
4, 5, 7, and 8	Not Used	Not Used

The following table shows wiring of straight-through and crossover cables for a 10/100BASE-T port.

Figure 6-2 Twisted Pair Connections for a 10/100BASE-T Port

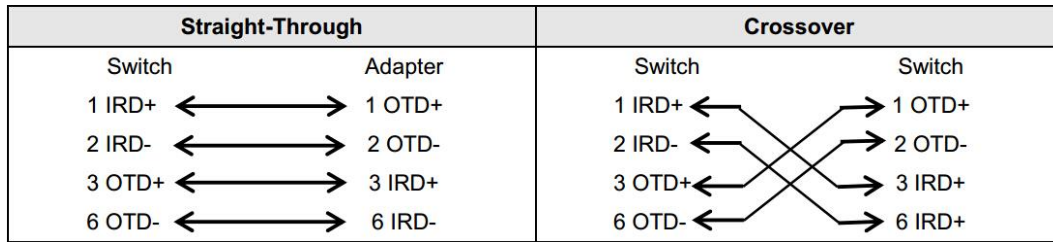

6.1.2 Optical Cable Connection

Select a single-mode fiber (SMF) or multimode fiber (MMF) for connections based on the type of the optical transceiver inserted into an optical port. [Figure 6-3](#) shows the connections.

Figure 6-3 Connecting the Optical Cables

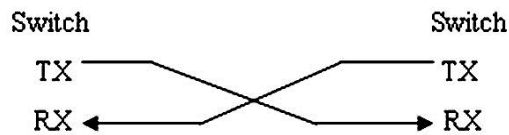

6.2 SFP Transceivers

Ruijie provides SFP transceivers (mini-GBIC) based on the port types. You can select one that suits your specific needs. In addition to the following 1GE SFP transceivers, the 1GE copper transceiver Mini-GBIC-GT is also supported. This document provides models and technical specifications of some 1GE SFP transceivers for reference. For details about the technical specifications, see *Ruijie Transceiver Installation and Reference Guide*.

Table 6-2 1GE Mini-GBIC (SFP) Models and Technical Specifications

Model	Wavelength (nm)	Fiber Type	DDM Supported (Yes/No)	Transmit Power (dBm)		Receive Power (dBm)	
				Min	Max	Min	Max
MINI-GBIC-SX-MM850	850	MMF	Yes	-9	-3	-20	-3
MINI-GBIC-LX-SM1310	1310	SMF	Yes	-9	-3	-26	0
GE-SFP-LH40-SM1310-BIDI	1310TX/1550RX	SMF	Yes	-3	3	-25	0
GE-SFP-LH40-SM1550-BIDI	1550TX/1310RX	SMF	Yes	-3	3	-25	0

GE-SFP-LX20-SM1310-BIDI	1310TX/1550RX	SMF	Yes	-8	-3	-23	-3
GE-SFP-LX20-SM1550-BIDI	1550TX/1310RX	SMF	Yes	-8	-3	-23	-3
MINI-GBIC-LH40-SM1310	1310	SMF	Yes	-5	0	-25	-3
MINI-GBIC-ZX80-SM1550	1550	SMF	Yes	-3	3	-26	-3
GE-SFP-LX03-SM1310-BIDI-I	1310TX/1550RX	SMF	Yes	-9	-3	-22	-3
GE-SFP-LX03-SM1550-BIDI-I	1550TX/1310RX	SMF	Yes	-9	-3	-22	-3
SFP-MM850	850	MMF	Yes	-9.5	-3	-17	-3
SFP-SM1310	1310	SMF	Yes	-9	-3	-20	-3

Table 6-3 1GE SFP Copper Transceivers

Standard	1000BASE-T SFP Module	DDM Supported (Yes/No)
1000BASE-T	Mini-GBIC-GT	No

Table 6-4 2.5GE Mini-GBIC (SFP) Models and Technical Specifications

Model	Wavelength (nm)	Fiber Type	Trusted Platform Module (DDM) (Yes/No)	Transmit Power (dBm)		Receive Power (dBm)	
				Min	Max	Min	Max
2.5G-SFP-LX03-SM1310-BIDI-I	1310TX/1550RX	SMF	YES	-9	-3	-16	0
2.5G-SFP-LX03-SM1550-BIDI-I	1550TX/1310RX	SMF	YES	-9	-3	-16	0

Table 6-5 Cabling Specifications of SFP Transceivers

SFP Transceiver Model	Port Type	Fiber Type	Core Size (µm)	Max Cabling Distance
SFP-SM1310	LC	SMF	9/125	10 km (6.21 miles)

SFP Transceiver Model	Port Type	Fiber Type	Core Size (µm)	Max Cabling Distance
MINI-GBIC-LX-SM1310	LC	SMF	9/125	10 km (6.21 miles)
GE-SFP-LH40-SM1310-BIDI	LC	SMF	9/125	40 km (24.85 miles)
GE-SFP-LH40-SM1550-BIDI	LC	SMF	9/125	40 km (24.85 miles)
GE-SFP-LX20-SM1310-BIDI	LC	SMF	9/125	20 km (12.43 miles)
GE-SFP-LX20-SM1550-BIDI	LC	SMF	9/125	20 km (12.43 miles)
MINI-GBIC-LH40-SM1310	LC	SMF	9/125	40 km (24.85 miles)
MINI-GBIC-ZX80-SM1550	LC	SMF	9/125	80 km (49.71 miles)
GE-SFP-LX03-SM1310-BIDI-I	LC	SMF	9/125	3 km (1.86 miles)
GE-SFP-LX03-SM1550-BIDI-I	LC	SMF	9/125	3 km (1.86 miles)
MINI-GBIC-SX-MM850	LC	MMF	62.5/125	275 m (902.23 ft.)
			50/125	550 m (1,804.46 ft.)
SFP-MM850	LC	MMF	62.5/125	275 m (902.23 ft.)
			50/125	550 m (1,804.46 ft.)
2.5G-SFP-LX03-SM1310-BIDI-I	LC	MMF	9/125	3 km (1.86 miles)
2.5G-SFP-LX03-SM1550-BIDI-I	LC	MMF	9/125	3 km (1.86 miles)
Mini-GBIC-GT	RJ45 Ethernet cable	CAT5 or better UTP or STP cable		100 m (328.08 ft.)

⚠ Caution

- For optical transceivers with a cabling distance of no less than 40 km (24.85 miles), install an optical attenuator to avoid overload on an optical receiver when using short-distance SMFs.
- An optical transceiver is a laser transmitter. Do not look into the light source to prevent it from burning your eyes.
- To keep the optical transceiver clean, make sure that the unused ports remain capped.

Table 6-6 BIDI Optical Transceiver Pairing

Rate/Distance	Pairing Model
1000 Mbps/3 km (1.86 miles)	<ul style="list-style-type: none"> ● GE-SFP-LX03-SM1310-BIDI-I ● GE-SFP-LX03-SM1550-BIDI-I

1000 Mbps/20 km (12.43 miles)	<ul style="list-style-type: none"> ● GE-SFP-LX20-SM1310-BIDI ● GE-SFP-LX20-SM1550-BIDI
1000 Mbps/40 km (24.85 miles)	<ul style="list-style-type: none"> ● GE-SFP-LH40-SM1310-BIDI ● GE-SFP-LH40-SM1550-BIDI

⚠ Caution

BIDI optical transceivers must be used in pairs. For example, if GE-SFP-LX20-SM1310-BIDI is used at one end, GE-SFP-LX20-SM1550-BIDI must be used at the other end.

6.3 Lightning Protection

6.3.1 Installing the AC Power Arrester (Power Strip with Surge Protection)

When an alternating current (AC) power cord is introduced from outdoors and directly connected to the AC power port of the switch, the power port must be connected to an external power arrester to safeguard the switch against lightning strikes. The power arrester can be fixed on the rack, workbench, or wall in the equipment room by using cable ties and screws. AC power enters the power arrester before entering the switch.

Figure 6-4 Power Arrester

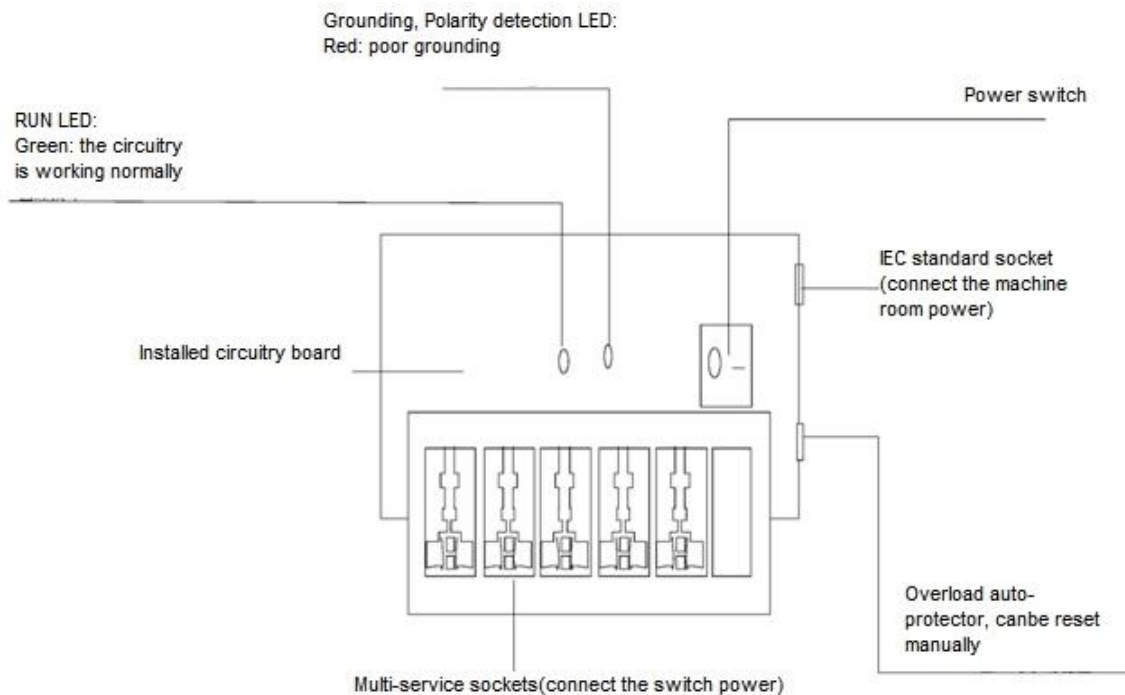

⚠ Caution

The power arrester is not delivered with the equipment. Please purchase it based on actual requirements.

Precautions during the installation:

- Make sure that the PE terminal of the power arrester is well grounded.
- After the AC power plug of the switch is connected to the socket of the power arrester, the lightning protection function is implemented only if the running status LED is green and the alarm LED is off.
- If the alarm LED on the power arrester is red, check whether it is caused by a poor grounding connection or by the reversed connection of the neutral and live wires. The detection method is as follows: Use a multimeter to measure the polarity of the power arrester when the alarm LED is red. If the neutral wire is on the left and the live wire is on the right (facing the socket), the PE terminal of the power arrester is not grounded. If not, the polarity of the power arrester should be reversed. In this case, open the power arrester and reverse its polarity. If the alarm LED is still red, the PE terminal of the power arrester is not grounded.

6.3.2 Installing the Ethernet Port Arrester

Please connect an Ethernet port arrester to the switch to prevent the damage by lightning strikes before connecting an outdoor Ethernet cable to the switch.

- Tools: Phillips screwdriver or flat-blade screwdriver, multimeter, and diagonal pliers
- Installation steps
 - a Tear one side of the protective paper for the double-sided adhesive tape and paste the tape to the enclosure of the Ethernet port arrester. Tear the other side of the protective paper for the double-sided adhesive tape and paste the Ethernet port arrester to the switch enclosure. The paste position for the Ethernet port arrester should be as close to the grounding lug of the switch as possible.
 - b Based on the distance between the grounding lug of the switch and the Ethernet port arrester, cut the grounding cable of the Ethernet port arrester and firmly tighten the grounding cable to the grounding lug of the switch.
 - c Use a multimeter to check whether the grounding cable for the arrester is in good contact with the grounding lug and the enclosure of the switch.
 - d Connect the Ethernet port arrester by using an adapter cable (note that the external Ethernet cable is connected to the IN end, while the adapter cable connected to the switch is connected to the OUT end) and check whether the module LED is normal.
 - e Use a nylon cable tie to bind the cables.

Figure 6-5 Installing an Ethernet Port Arrester

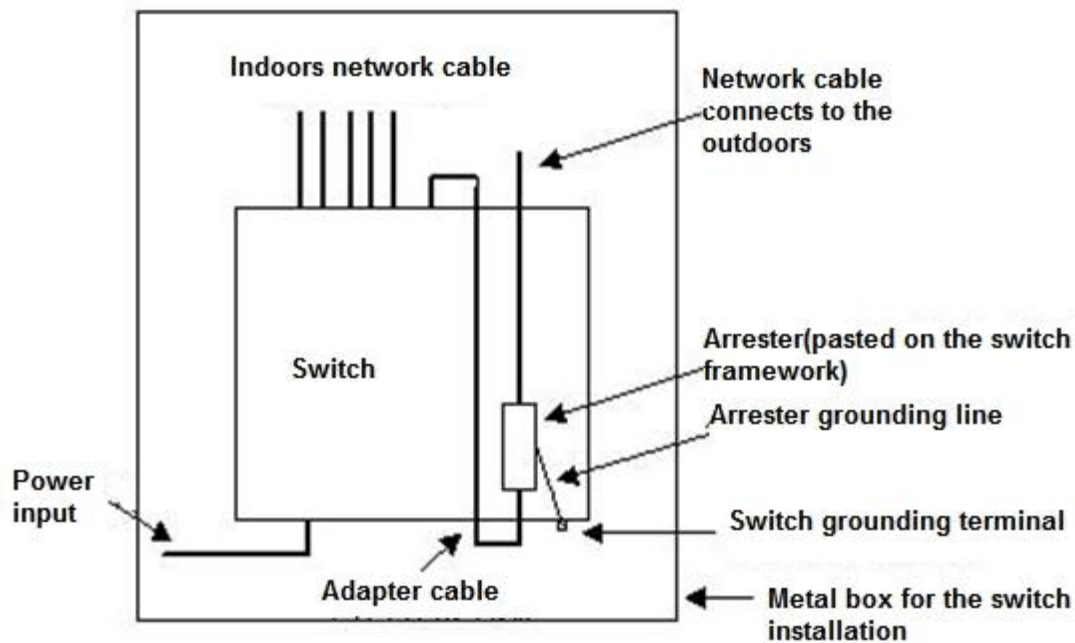

⚠ Caution

- The Ethernet port arrester is only for a 10 Mbps, 100 Mbps, or 1000 Mbps RJ45 port.
- The Ethernet port arrester is not delivered with the equipment. Please purchase it based on actual requirements. The user manual for Ethernet port arresters contains technical parameters and maintenance and installation instructions. Carefully read this manual during installation.

Pay attention to the following situations during the actual installation to avoid influencing the performance of an Ethernet port arrester:

- The arrester is incorrectly connected to the cables. Connect the external Ethernet cable to the IN end and connect the Ethernet port of the switch to the OUT end.
- The Ethernet port arrester is incorrectly grounded. The grounding cable of the arrester should be as short as possible to ensure that it is in good contact with the grounding lug of the switch. Use a multimeter to confirm the contact condition after grounding.
- Not all Ethernet ports are installed with Ethernet port arresters. If outdoor Ethernet cables connect the switch ports to the peer equipment, Ethernet port arresters need to be installed on all the ports for the purpose of lightning protection.

6.4 Recommended Cabling

When the switch is installed in a standard 19-inch cabinet, secure the cables around the cable management brackets. Top cabling or bottom cabling is adopted according to the actual situation in the equipment room. All adapted connectors should be placed at the bottom of the rack in an orderly manner instead of outside the rack that is easy to touch. Power cords are routed beside the rack. Top cabling or bottom cabling is adopted according

to the actual situation in the equipment room, such as the positions of the DC power distribution box, AC socket, or lightning protection box.

6.4.1 Requirement for the Minimum Bend Radius of Cables

- The bend radius of a fixed power cord, Ethernet cable, and flat cable should be over five times greater than their respective external diameters. The bend radius of these cables that are often bent or plugged should be over seven times greater than their respective external diameters.
- The bend radius of a fixed common coaxial cable should be over seven times greater than its external diameter. The bend radius of these cables that are often bent or plugged should be over 10 times greater than their respective external diameters.
- The minimum bend radius of a high-speed cable, such as an SFP+ cable, should be 5 times the overall diameter of the cable. If the cable is constantly bent, plugged or unplugged, the bend radius should be 10 times the overall diameter.
- The minimum bend radius of optical cables should meet the following requirements.
 - The diameter of the optical cable tray should be no less than 25 times greater than that of the optical cable.
 - When an optical cable is moved, its bend radius should be no less than 20 times greater than its diameter.
 - During cabling of an optical cable, its bend radius should be no less than 10 times greater than its diameter.

6.4.2 Precautions for Cable Bundling

- Before cables are bundled, mark labels and stick the labels to cables wherever appropriate.
- Cables should be neatly and properly bundled in the rack without twisting or bending, as shown in [Figure 6-6](#).

Figure 6-6 Bundling Cables (1)

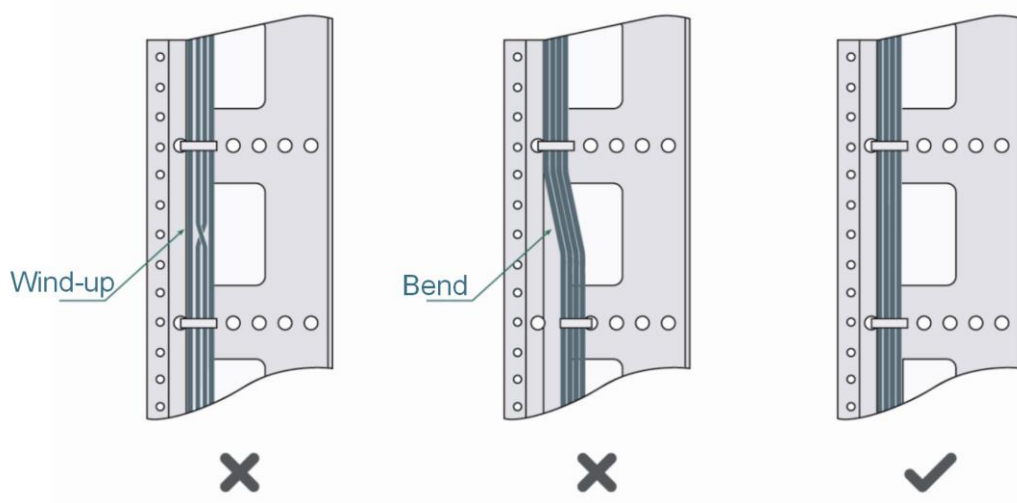

- Cables of different types (such as power cords, signal cables, and grounding wires) should be separated in cabling and bundling. Mixed bundling is not allowed. When they are close to each other, you are advised to

adopt crossover cabling. In the case of parallel cabling, maintain a minimum distance of 30 mm (1.18 in.) between power cords and signal cables.

- The cable management brackets and cabling troughs inside and outside the rack should be smooth without sharp corners.
- The metal holes traversed by cables should have a smooth and fully rounded surface or an insulated lining.
- Use cable ties to bundle cables properly. Please do not connect two or more cable ties to bundle cables.
- After bundling up cables with cable ties, cut off the remaining part. The cut should be smooth and trim without sharp corners, as shown in [Figure 6-7](#).

Figure 6-7 Bundling Cables (2)

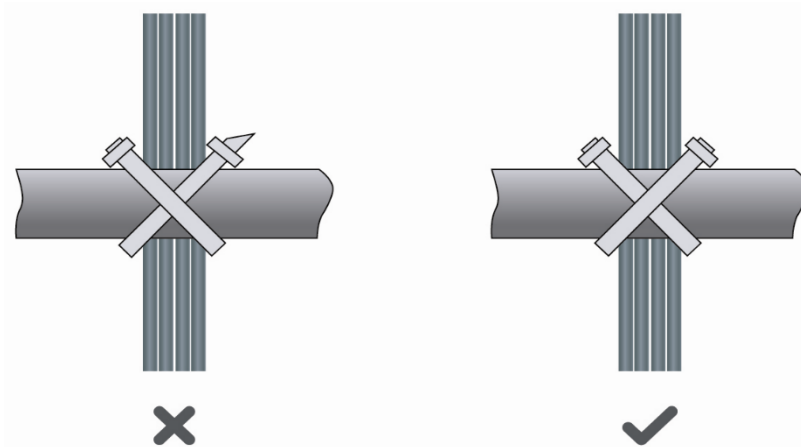

- When cables need to be bent, bundle them first but do not tie cables within the bend. Otherwise, stress may be generated on the cables and cause the wires inside to break, as shown in [Figure 6-8](#).

Figure 6-8 Bundling Cables (3)

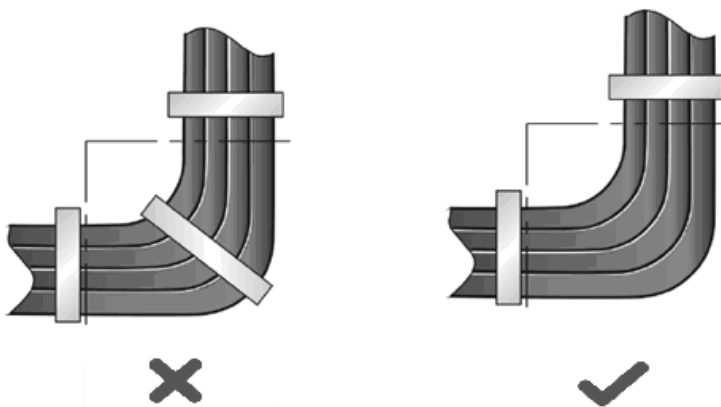

- Cables not to be assembled or the remaining parts of cables should be folded and placed in a proper position of the rack or cable management trough. The proper position refers to a position that does not affect the equipment running or damage the equipment or cables.
- Power cords must not be bundled on the guide rails of moving parts.
- The power cords connecting moving parts such as door grounding wires should be reserved with some

excess after being assembled to avoid suffering tension or stress. When a moving part reaches the installation position, the remaining cable part should not touch heat sources, sharp corners, or sharp edges. If heat sources must be touched, high-temperature cables should be used.

- When using screw threads to secure a cable lug, ensure that the bolt or screw is properly tightened and take measures to prevent it from loosening, as shown in [Figure 6-9](#).

Figure 6-9 Fastening Cables

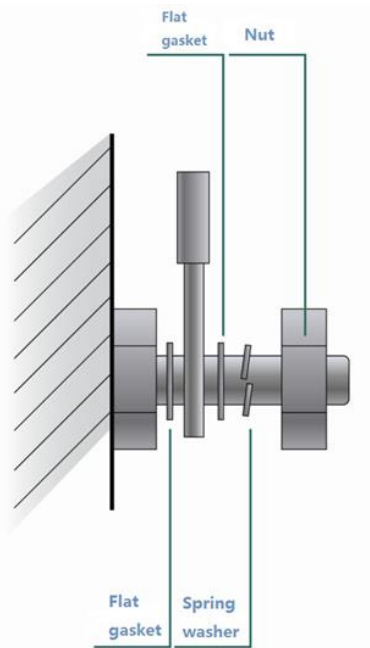

- Hard power cords should be secured near the cable termination area to prevent stress on the cable termination area and cables.
- Do not use tapping screws to secure cable lugs.
- Power cords of the same type and in the same cabling direction should be bundled up into cable bunches, with cables in cable bunches clean and straight.
- Bundle cables by using cable ties according to the following table.

Cable Bunch Diameter	Bundling Spacing
10 mm (0.39 in.)	80–150 mm (3.15–5.91 in.)
10–30 mm (0.39–1.18 in.)	150–200 mm (5.91–7.87 in.)
30 mm (1.18 in.)	200–300 mm (7.87–11.81 in.)

- Do not tie cables or bundles in a knot.
- For wiring terminal blocks (such as circuit breakers) with cord end terminals, the metal part of the cord end terminal should not be exposed outside the terminal block when assembled.

6.5 Site Selection

- The equipment room should be at least 5 km (3.11 miles) away from heavy pollution sources, such as smelters, coal mines, and thermal power plants. The equipment room should be at least 3.7 km (2.30 miles) away from medium pollution sources, such as the chemical factory, rubber factory, and electroplating factory. The equipment room should be at least 2 km (1.24 miles) away from light pollution sources, such as the food factory and leather plant. If the pollution source is unavoidable, the equipment room should be located on the windward side of the pollution source perennially with advanced protection.
- The equipment room should be at least 3.7 km (2.30 miles) away from the sea or salt lake. Otherwise, the equipment room must be sealed, with an air conditioner installed for temperature control. Saline soil cannot be used for construction. Otherwise, you should select equipment with advanced protection against severe environments.
- Do not build the equipment room in the proximity of livestock farms. Otherwise, the equipment room should be located on the windward side of the pollution source perennially. The previous livestock house or fertilizer warehouse cannot be used as the equipment room.
- The equipment room should be firm enough to withstand severe weather conditions such as windstorms, heavy rain, and dense dust. If the dust is unavoidable, keep the door and window away from the pollution source.
- The equipment falls into Class A. Therefore, the equipment room should be located away from the residential area. Otherwise, the equipment room should meet construction specifications to avoid noise and radio interference.
- Make sure the air vent of the equipment room is away from the sewage pipe, septic tank, and sewage treatment tank. Keep the equipment room under positive pressure to prevent corrosive gas from entering the equipment room to corrode components and circuit boards.
- Keep the equipment room away from industrial boilers and heating boilers.
- The equipment room should be on the second floor or higher. Otherwise, the equipment room floor should be 600 mm (23.62 in.) higher than the highest flood level ever recorded.
- Make sure no cracks or holes exist in the wall and floor. If there are cable entries in the wall or window, take proper sealing measures. Ensure that the wall is flat, wear-resistant, and dust-free, meeting standards for flame resistance, soundproofing, heat absorption, dust reduction, and electromagnetic shielding.
- Keep the door and the window closed to make the equipment room sealed.
- You are advised to use the steel door for soundproofing.
- Do not use sulfur-containing materials.
- Keep the air conditioner from blowing wind straight toward the equipment or blowing water drops from the window or air vent toward the equipment.

Contents

1 Overview	4
1.1 About the RG-ES220GS-P-V2	4
1.2 Equipment Appearance	4
1.2.1 Front Panel.....	4
1.2.2 Rear Panel	5
1.2.3 LEDs	6
1.3 Cooling.....	6
1.4 Technical Specifications	7
2 Preparing for Installation	9
2.1 Package Contents.....	9
2.2 Safety Guidelines.....	9
2.2.1 General Precautions	9
2.2.2 Chassis-Lifting Guidelines	10
2.2.3 Electricity Safety	10
2.2.4 Preventing ESD Damage.....	11
2.2.5 Laser Safety	11
2.3 Site Requirements	12
2.3.1 Floor Loading	12
2.3.2 Airflow.....	12
2.3.3 Space	12
2.3.4 Temperature and Humidity.....	12
2.3.5 Cleanliness.....	12

2.3.6	Grounding	13
2.3.7	Preventing Electromagnetic Interference	14
2.3.8	Surge Protection	14
2.3.9	Installation Site.....	14
2.4	Rack Requirements	14
2.5	Tools	15
3	Installing the Switch	16
3.1	Before You Begin.....	16
3.2	Installing the Switch	16
3.2.1	Rack Mount.....	16
3.2.2	Workbench Mount.....	17
3.3	Grounding the Equipment.....	18
3.4	Connecting Cables.....	19
3.5	Bundling Cables.....	19
3.5.1	Precautions	19
3.5.2	Bundling Procedure	19
3.6	Verifying Installation.....	19
4	Commissioning.....	20
4.1	Power-on.....	20
4.2	Logging In to the Management Interface.....	20
5	Troubleshooting.....	21
5.1	General Troubleshooting Flowchart	21
5.2	Common Faults.....	21
6	Appendix.....	23

6.1 Connectors and Media.....	23
6.1.1 10Or100Or1000BASE-T Port	23
6.1.2 Optical Cable Connection	24
6.2 SFP Transceivers	24
6.3 Lightning Protection	27
6.3.1 Installing the AC Power Arrester (Power Strip with Surge Protection)	27
6.3.2 Installing the Ethernet Port Arrester	28
6.4 Recommended Cabling	29
6.4.1 Requirement for the Minimum Bend Radius of Cables	30
6.4.2 Precautions for Cable Bundling	30
6.5 Site Selection	33

1 Overview

1.1 About the RG-ES220GS-P-V2

The RG-ES220GS-P-V2 Ethernet switch provides 18 10/100/1000BASE-T ports, two 1GE SFP ports, one Reset button, one DIP switch, and several LEDs on the front panel, along with an AC power port and a grounding stud on the rear panel. Ports 1–16 support Power over Ethernet (PoE) Out.

Figure 1-1 RG-ES220GS-P-V2 Appearance



Note

- 1GE SFP port: Supports only 1GE SFP optical transceivers (not compatible with 100 Mbps optical cables).
- 10/100/1000BASE-T port: Supports auto-negotiation at 10 Mbps, 100 Mbps, and 1000 Mbps.

1.2 Equipment Appearance

1.2.1 Front Panel

Figure 1-2 Front Panel of the RG-ES220GS-P-V2

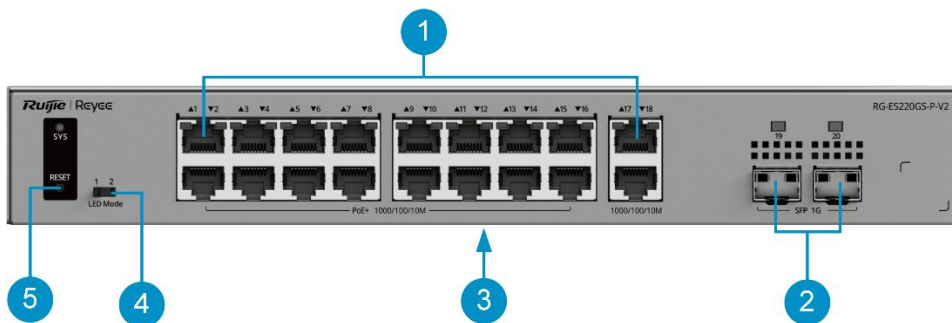

Table 1-1 Components on the Front Panel

No.	Component	Silkscreen	Description
1	RJ45 port	1000/100/10M	10/100/1000BASE-T ports, with ports 1–16 supporting PoE Out.
2	SFP port	SFP 1G	1GE SFP port, supporting 1GE SFP transceiver (hot-swappable)
3	Nameplate	-	It is located at the bottom of the switch.
4	DIP switch	LED Mode	Toggle the DIP switch to change the LED modes of ports 1–16. <ul style="list-style-type: none"> LED mode 1 (switching mode): When the DIP switch is toggled to the left, the port LEDs display the data transmission status. LED mode 2 (PoE mode): When the switch is toggled to the right, the port LEDs display the PoE status.
5	Reset button	RESET	<ul style="list-style-type: none"> Press and hold the button for less than 2 seconds. The switch is reset. Press and hold the button for 2–5 seconds. No action is performed. Press and hold the button for more than 5 seconds, and release the button until the system status LED starts blinking to restore factory settings and restart the switch.

Note

For details about LEDs on the front panel, see "LEDs."

1.2.2 Rear Panel

Figure 1-3 Rear Panel of the RG-ES220GS-P-V2



Table 1-2 Components on the Rear Panel

No.	Component	Description
1	Grounding stud	Used to connect the switch to the ground.
2	Power port	Indicates a three-pin power port used for AC power connection.
3	Power cable spring clip hole	Secures the power cord retention clip to the holes.

1.2.3 LEDs

Figure 1-4 RG-ES220GS-P-V2 LEDs

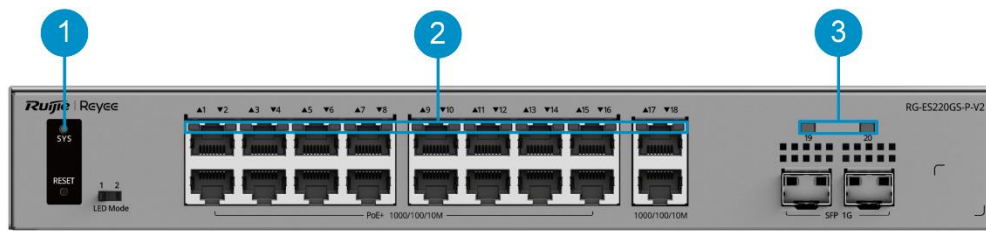

Table 1-3 LEDs

No.	Component	Silkscreen	Description
1	System status LED	SYS	<ul style="list-style-type: none"> ● Off: The switch is not powered on. ● Slow blinking green (0.5 Hz): The switch is operating normally but is not connected to Ruijie Cloud. ● Fast blinking green (10 Hz): The switch is upgrading or restarting, and is temporarily unavailable. ● Solid green: The switch is operating normally and connected to Ruijie Cloud. ● Slow blinking yellow (0.5 Hz): The PoE power is insufficient. ● Slow blinking red (0.5 Hz): A loop occurs on the switch with loop guard enabled.
2	RJ45 port LED	1–18	<p>LEDs of ports 1–16 support switching mode and PoE mode, which can be switched by toggling the DIP switch on the front of the switch.</p> <ul style="list-style-type: none"> ● Switching mode: <ul style="list-style-type: none"> ○ Off: The port is not connected. ○ Solid green: The port is operating at 1000 Mbps, 100 Mbps, or 10 Mbps, but is not receiving or sending data. ○ Blinking green: The port is operating at 1000 Mbps, 100 Mbps, or 10 Mbps, and is receiving or sending data. ● PoE mode: <ul style="list-style-type: none"> ○ Off: PoE is disabled on the port. ○ Solid green: PoE is enabled on the port. ○ Blinking green: PoE overload occurs on the port.
3	SFP port LED	19, 20	<ul style="list-style-type: none"> ● Off: The port is not connected. ● Solid green: The port is operating at 1000 Mbps, but is not receiving or sending data. ● Blinking green: The port is operating at 1000 Mbps, and is receiving or sending data.

1.3 Cooling

The RG-ES220GS-P-V2 switch has one fixed fan, which adopts air cooling and left-to-right airflow design. To ensure that the equipment works properly in the specified environment, a minimum clearance of 10 cm (3.94 in.)

must be maintained around the equipment for air circulation and ventilation. Dust the equipment every three months to avoid obstructing the air-exhaust grid of the chassis.

1.4 Technical Specifications

Warning

- This equipment is not suitable for use in locations where children are likely to be present.
- Operation of this equipment in a residential environment could cause radio interference.

Table 1-4 Technical Specifications

Parameter Type	Parameter Name	RG-ES220GS-P-V2
System Specifications	Forwarding rate	29.76 Mpps
	Switching capacity	40 Gbps(bit/s)
	Flash memory	8 MB
Port Specifications	Total number of optical ports	2
	Total number of RJ45 ports	18
	Number of 10/100/1000BASE-T ports	18
	Number of 1GE SFP ports	2
	Reset button	1
	LEDs	1 x system status LED 18 x Ethernet port LEDs 2 x SFP port LEDs
	DIP switch	LED mode switch toggled to left (Mode 1): The port LED status indicates the status of traffic transmission. Solid green means that the port is link up, while blinking green means that the port is transmitting and receiving data. LED mode switch toggled to right (Mode 2): The port LED status indicates the PoE status. Solid green means that the port is supplying power, while blinking green means that the port is in power overload state.
Power Supply and Consumption	Power supply	Fixed power supply
	Power input	220 V AC power supply: <ul style="list-style-type: none"> ● Rated input voltage: 100 V AC to 240 V AC, 50 Hz to 60 Hz ● Maximum input voltage: 90 V AC to 264 V AC, 47 Hz to 63 Hz ● Rated input current: 6 A
	Maximum power consumption	20W (with no PoE load) 287W (with full PoE load)
	Number of PoE Out ports	16

Parameter Type	Parameter Name	RG-ES220GS-P-V2
	Number of PoE/PoE+ Out ports	16
	PoE Out standard	PoE/PoE+ (IEEE 802.3af/at)
	PoE power pins	1–2 (+), 3–6 (-)
	PoE budget per port	30 W
	PoE budget	250 W
Dimensions and Weight	Product dimensions (W x D x H)	300 mm x 223 mm x 43.6 mm (11.81 in. x 8.78 in. x 1.72 in.)
	Weight	2.06 kg (4.54 lbs) (without packaging materials)
	Shipping weight	2.95Kg (6.50 lbs)
	Casing	Metal
Interface	EEE	Yes
Environment and Reliability	Mounting options	Rack/Desk
	Hot swapping of cables	Hot swapping supported by the service port and power connector
	Fan	1 x fixed fan
	Cooling	Air cooling, left-to-right airflow
	MTBF	200,000 hours
	ESD protection	Air discharge: 8 kV Contact discharge: 6 kV
	Surge protection	Service port: ± 6 kV for common mode Power connector: ± 6 kV for common mode and ± 6 kV for differential mode
	Operating temperature	0°C to 40°C (32°F to 104°F)
	Storage temperature	-40°C to +70°C (-40°F to +158°F)
	Operating humidity	10% RH to 90% RH (non-condensing)
	Storage humidity	5% RH to 95% RH (non-condensing)
	Altitude	-500 m to +5,000 m (-1,640.42 ft. to +16,404.20 ft.)
Certification and Regulatory Compliance	EMC	EN 55032 EN 61000-3-2 EN 61000-3-3 EN 55035 EN 300 386
	Safety compliance	EN 62368-1 IEC 62368-1
	Certification	CE,CB

2 Preparing for Installation

2.1 Package Contents

Table 2-1 Package Contents

No.	Item	Quantity
1	RG-ES220GS-P-V2 switch	1
2	Rubber pad	4
3	<i>User Manual</i>	1
4	<i>Warranty Card</i>	1
5	M3 x 6 mm cross recessed countersunk head screw	6
6	Rack-mount bracket	2
7	Power cord	1
8	Power cord retention clip	1

Note

The package contents are subject to the purchase contract, and actual delivery may vary. Please check the items carefully against the package contents or purchase contract. If you have any questions, please contact the distributor.

2.2 Safety Guidelines

Note

- To avoid personal injury or equipment damage, review the safety guidelines in this chapter before you begin the installation.
 - The following safety guidelines may not include all the potentially hazardous situations.
-

2.2.1 General Precautions

- Install the equipment in a standard 19-inch rack and ensure that the rack and power distribution system are properly grounded.
- Never operate the equipment in a wet environment, and avoid any liquids inside it. Keep the chassis clean and dust-free.
- Keep the equipment away from heat sources.
- Keep the equipment away from walk areas.
- During installation and maintenance, do not wear loose clothing or ornament that may get caught in the

chassis.

- Keep tools and accessories away from walk areas.

2.2.2 Chassis-Lifting Guidelines

- Avoid moving the equipment frequently.
- Turn off all power supplies and disconnect all cables before lifting or moving the equipment.
- Two or more people are required to lift the chassis. Keep balance and prevent personal injuries when lifting or moving the equipment.

2.2.3 Electricity Safety

Warning

- Any deviation from standard or improper electrical operations can result in accidents such as fires or electric shocks, potentially causing severe or even fatal harm to both individuals and equipment.
 - Direct or indirect touch through a wet object on high-voltage and mains supply can bring a fatal danger.
-
- Always observe the local regulations and standards. Only qualified personnel should be allowed to operate the equipment.
 - Carefully check the work area for potential hazards, including ungrounded power system, absent safety grounds, and damp floors.
 - Locate the emergency power-off switch in the room before installation. In the case of an accident, cut off the power supply immediately.
 - Never assume that power is connected to or disconnected from a circuit. Always check.
 - Select the right leakage protector (also called "leakage current switch" or "leakage current breaker") for the power supply system. This equipment automatically disconnects the power supply in the event of leakage and the risk of electric shock. A leakage protector should meet the following requirements:
 - The rated leakage action current of each leakage protector must be at least twice the total maximum leakage current of all connected power supplies.
Example:
If a system has 16 identical power supplies, each with a maximum leakage current of 3.5 mA:
Total leakage current = 16 x 3.5 mA = 56 mA
For a 30 mA leakage protector:
Maximum number of power supplies per protector = 30 mA/2/3.5 mA ≈ 4
Therefore, only four power supplies can be connected to one 30 mA leakage protector.
To support 16 power supplies, at least four 30 mA leakage protectors are required.
Always ensure:
Rated leakage operating current/2 > Total maximum leakage current of connected power supplies
 - The rated leakage non-action current of a leakage protector should be 50% of the leakage action current. If the non-action current value is too small, the high sensitivity level can cause the circuit to break, leading to power cutoff and service interruption, even if the leakage current value is normal.

For example, if a leakage protector has a rated leakage action current of 30 mA, the rated leakage non-action current should be 15 mA. The leakage protector will not activate unless the leakage current exceeds 15 mA.

⚠ Caution

- To ensure personal safety, each leakage protector in the system must have a rated leakage action current equal to or below 30 mA, which is the recognized safety threshold for human body current. If the total leakage current of the system exceeds twice the 30 mA limit, the system must be equipped with two or more leakage protectors to maintain safety.
 - The leakage current values vary with equipment. For the leakage current value of each equipment model, see "Technical Specifications."
-

2.2.4 Preventing ESD Damage

- Ensure that the chassis is connected to earth ground.
- Keep the site as dust free as possible.
- Maintain appropriate humidity conditions.
- Before installing any pluggable modules, wear an anti-ESD wrist strap and make sure that it is properly grounded.
- Avoid contact between the printed circuit boards and clothing. The anti-ESD wrist strap only protects the printed circuit boards from ESD voltages on the body. ESD voltages on clothing can still cause damage.

2.2.5 Laser Safety

The equipment supports various types of optical transceivers, which are Class 1 laser products.

Precautions:

- When an optical transceiver is working, ensure that its port is connected to an optical cable or covered by a dust cap to keep out dust and prevent it from burning your eyes.
- Do not stare into an optical port.

Figure 2-1 Laser Product ID



⚠ Caution

Do not approach or stare into an optical port under any circumstances. This may cause permanent damage to your eyes.

2.3 Site Requirements

The equipment must be installed indoors for normal operation and prolonged service life.

The installation site must meet the following requirements.

2.3.1 Floor Loading

Assess the combined weight of the equipment and its accessories, such as rack, chassis, and power modules, and verify that the floor under the rack can bear the weight.

2.3.2 Airflow

The equipment adopts natural cooling. Reserve a sufficient clearance around the equipment to ensure proper ventilation.

2.3.3 Space

You are advised to have a pathway of at least 0.8 m (2.62 ft.) wide in the equipment room. This space ensures that you can move the chassis and swap the modules easily.

Do not install the equipment against a wall. Instead, maintain a minimum clearance of 10 cm (3.94 in.) around the equipment for heat dissipation and equipment maintenance.

2.3.4 Temperature and Humidity

To ensure the normal operation and a prolonged service life of the equipment, maintain an appropriate temperature and humidity in the installation environment.

Prolonged exposure to inappropriate temperature and humidity conditions can cause damage to the equipment.

- In an environment with high relative humidity, insulating materials are prone to poor insulation or even electricity leakage.
- In an environment with low relative humidity, insulating gaskets may shrink, resulting in screw loosening.
- In a dry environment, static electricity is more likely to occur, posing a risk to the internal circuits of equipment.
- A high temperature can accelerate the aging process of insulation materials, greatly reducing the availability of the equipment and severely affecting its service life.

2.3.5 Cleanliness

Dust poses a significant hazard to the equipment. Dust on the enclosure causes electrostatic adhesion, leading to poor contact of the metallic joints. Electrostatic adhesion is more likely to occur in an indoor environment with relatively low humidity, not only affecting the service life of the equipment, but also causing communication faults.

The following table lists the requirements for dust concentration and particle size in the equipment room.

Table 2-2 Requirements for Dust

Particle Diameter	Unit	Concentration
≥ 0.5 μm	Particles/m ³	≤ 3.5 × 10 ⁶
≥ 5 μm	Particles/m ³	≤ 3.5 × 10 ⁶

Apart from dust, there are also requirements on the salt, acid, and sulfide in the air of the equipment room. These harmful substances will accelerate metal corrosion and component aging. Therefore, the equipment room should be properly protected against harmful gases, such as sulfur dioxide, hydrogen sulfide, nitrogen dioxide, and chlorine gas. The following table lists the limits on harmful gases.

Table 2-3 Requirements for Gases

Gas	Average (mg/m ³)	Maximum (mg/m ³)
Sulfur dioxide (SO ₂)	0.3	1.0
Hydrogen sulfide (H ₂ S)	0.1	0.5
Nitrogen dioxide (NO ₂)	0.5	1.0
Chlorine gas (Cl ₂)	0.1	0.3

 **Note**

Average refers to the average value of harmful gases measured in a week. **Maximum** refers to the upper limit of harmful gases measured in a week for up to 30 minutes every day.

2.3.6 Grounding

A proper grounding system is crucial for ensuring stable and reliable operation, as well as preventing lightning strikes and interference. Carefully check the grounding conditions at the installation site according to the grounding requirements, and complete grounding properly based on the site situation.

- Safety Grounding

Ensure that the rack and power distribution system are securely grounded if the equipment uses the AC power supply. Otherwise, electric shocks may occur when the insulation resistance between the power module and the chassis decreases.

 **Caution**

- The building should provide a protective ground connection to ensure that the equipment is connected to a protective ground.
 - Verify that the AC socket is reliably connected to the protective grounding system of the building. If not, a protective grounding wire should be used to connect the protective grounding lug of the AC socket to the protective grounding system of the building.
-

- Lightning Grounding

The lightning protection system is an independent system composed of a lightning rod, a downlead conductor, and a connector connected to the grounding system. The grounding system is typically used for power reference grounding and safety grounding of the rack. Lightning grounding is required only for facilities, and is not required for the equipment.

- EMC Grounding

Electromagnetic compatibility (EMC) grounding includes shielded grounding, filter grounding, noise and interference suppression, and level reference.

2.3.7 Preventing Electromagnetic Interference

- Take interference prevention measures for the power supply system.
- Keep the equipment away from the grounding system or lightning protection grounding system of the power facility.
- Keep the equipment far away from high-frequency current equipment such as high-power radio transmitting stations and radar launchers.
- Take electromagnetic shielding measures when necessary.

2.3.8 Surge Protection

Although the equipment can guard against lightning strikes, strong lightning strikes may still damage the equipment. Take the following surge protection measures:

- Ensure that the grounding wire of the rack is in good contact with the ground.
- Ensure that the neutral point of the AC power socket is in good contact with the ground.
- Install a power arrester in front of the power input end to enhance surge protection for the power supply.

2.3.9 Installation Site

Regardless of whether the equipment is installed in a rack or on a workbench, ensure that the following conditions are met:

- Maintain a proper clearance around the air inlets and outlets for heat dissipation.
- Install the equipment in a standard 19-inch rack. Alternatively, place the equipment on a clean workbench. The installation of air conditioners is recommended in hot areas.
- The installation site has a good cooling and ventilation system.
- The installation site is sturdy enough to support the weight of the chassis and its accessories.
- The installation site is properly grounded.

2.4 Rack Requirements

If you plan to install the equipment in a rack, ensure that the rack meets the following conditions.

- (1) Use a four-post 19-inch rack.
- (2) The left and right square-hole rack posts are 465 mm (18.31 in.) apart.

Figure 2-2 19-Inch Rack

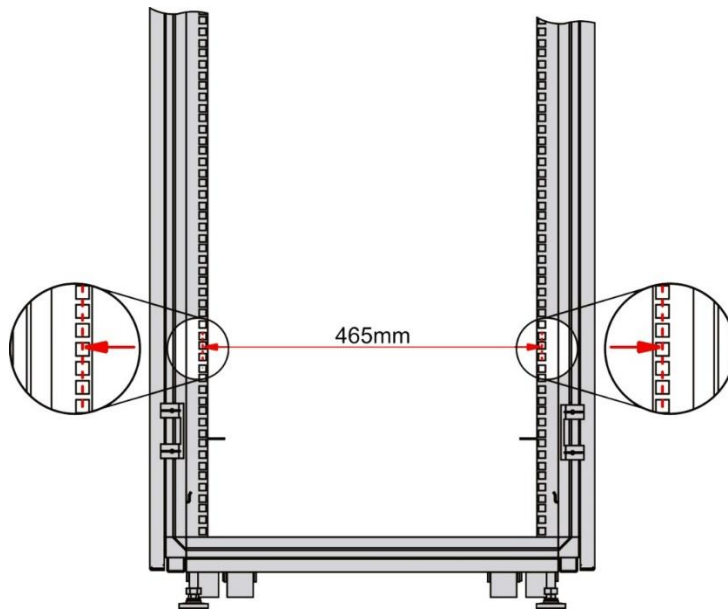

- (3) The square-hole rack post is at least 180 mm (7.09 in.) from the front door, and the front door is at most 25 mm (0.98 in.) thick. This ensures an available clearance of at least 155 mm (6.10 in.). The rack depth (distance between front and rear doors) is at least 1000 mm (39.37 in.).
- (4) The guide rails or tray can bear the weight of the equipment and its accessories.
- (5) The rack has a reliable grounding lug for the chassis to connect to earth ground.
- (6) The rack has a reliable ventilation system. The open area of front and rear doors is greater than 50%.

2.5 Tools

Table 2-4 Tools

Common Tools	Phillips screwdriver, cables, cage nuts, diagonal pliers, cable ties, and grounding wires
Dedicated Tools	Anti-ESD gloves, wire stripper, crimping pliers, RJ45 crimping pliers, and wire cutter
Meter	Multimeter

Note

The equipment is delivered without a toolkit. Prepare the preceding tools by yourself.

3 Installing the Switch

Caution

Before installing the equipment, ensure that guidelines and requirements in Chapter 2 have been met.

3.1 Before You Begin

- The installation site provides sufficient space for heat dissipation.
- The installation site meets the temperature and humidity requirements.
- The power supply is available at the installation site, and its current meets the requirements.
- The Ethernet cables have been deployed at the installation site.
- Locate the emergency power-off switch in the room before installation. In the case of an accident, cut off the power supply immediately.

3.2 Installing the Switch

3.2.1 Rack Mount

Install the RG-ES220GS-P-V2 switch in a standard 19-inch rack. The installation steps are as follows:

- (1) Take out the M3 x 6 mm cross recessed countersunk head screws delivered with the switch. Attach a rack-mount bracket to each side of the switch and secure it with three screws.

Figure 3-1 Securing Rack-Mount Brackets

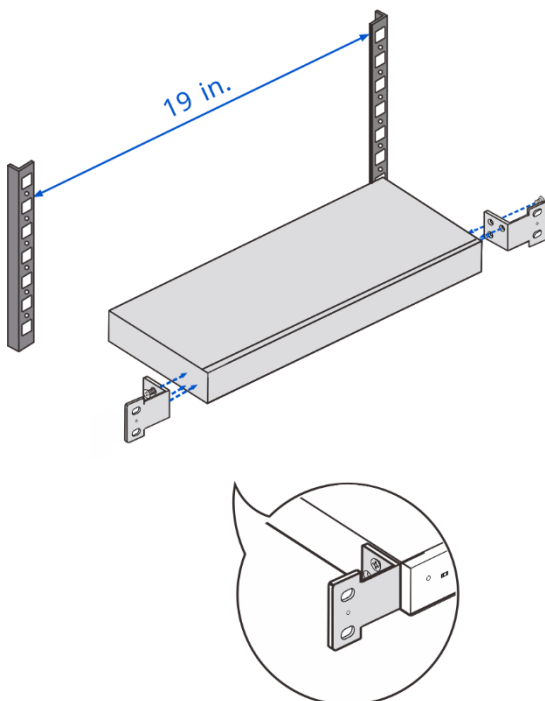

- (2) Horizontally position the switch at the desired location in the rack, and secure the other end of the rack-mount brackets to front square holes of the rack using four M6 screws and four cage nuts.

Figure 3-2 Installing the Switch in a Rack

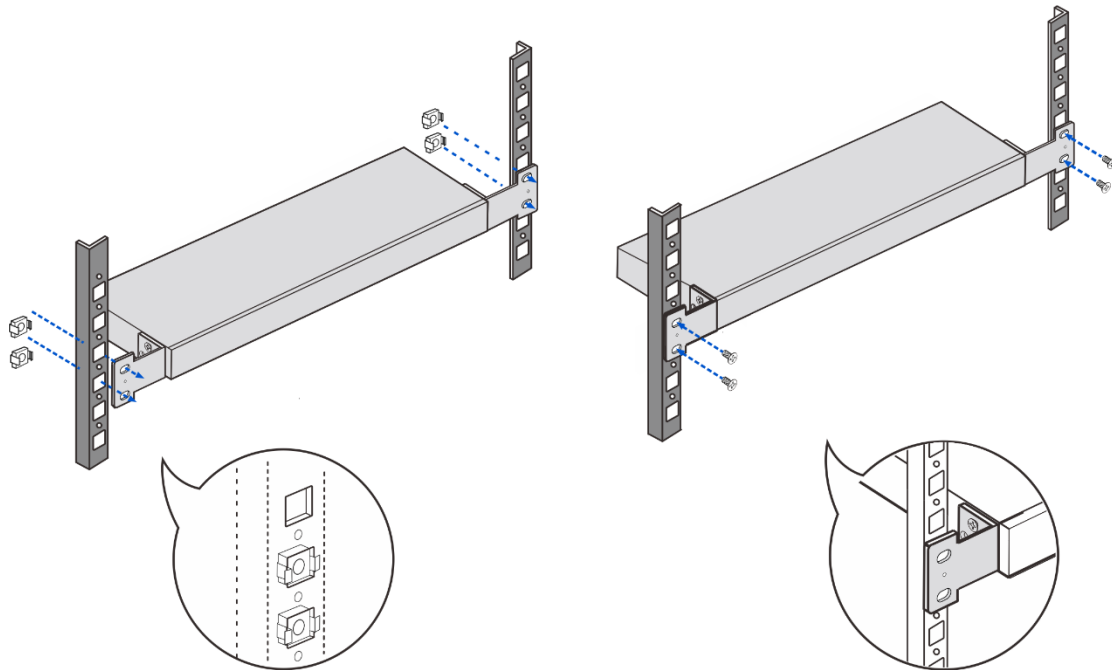

3.2.2 Workbench Mount

In most cases, users do not have a standard rack, and equipment can be placed on a clean workbench. The installation process is as follows:

- (1) Attach the four rubber pads in the package to the dents at the four corners on the bottom of the switch.

Figure 3-3 Attaching the Rubber Pads

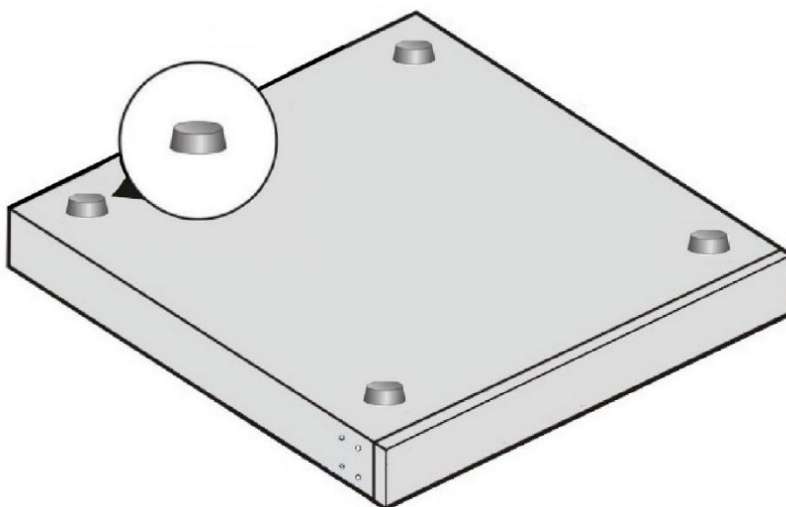

- (2) Place the equipment on a workbench.

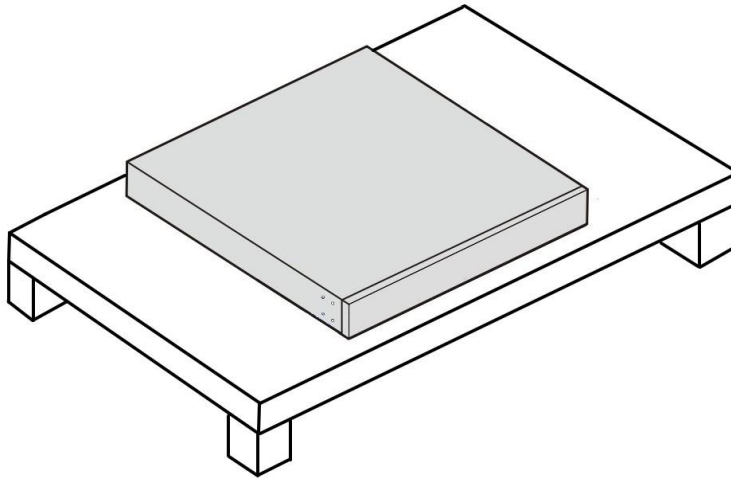
Figure 3-4 Placing the Equipment on a Workbench

3.3 Grounding the Equipment

Note

- If the equipment is installed on a workbench, connect the grounding wire to the nearest grounding bar or grounding point based on the onsite situation.
 - The grounding wire is not delivered with the equipment and needs to be purchased by the customer.
-

The equipment has a grounding stud on the rear panel. You are advised to connect the system grounding wire to it before using the equipment.

- (1) Purchase a grounding wire and connect one end to the grounding stud at the rear of the equipment.
- (2) Connect the other end to the grounding lug of the rack. Ensure the grounding lug of the rack has been connected to the grounding bar.

Caution

- To avoid personal injury and equipment damage, connect the switch to earth ground properly. The grounding resistance between the chassis and the ground should be less than 1 ohm.
 - The O&M personnel should verify whether the AC socket is reliably connected to the protective ground of the building. If not, the O&M personnel should use a protective grounding wire to connect the protective grounding lug of the AC socket to the protective ground of the building.
 - The power socket should be installed near the equipment and easily accessible.
 - During the equipment installation, connect the grounding wire first and disconnect it last.
 - The sectional area of a grounding wire should be determined according to the possible maximum current. Grounding wires with good conductors should be used.
 - Do not use bare wires.
-

3.4 Connecting Cables

Caution

- All cables must be routed indoors. Take surge protection measures if they need to be routed outdoors.
 - When connecting an optical cable, connect the transmit (TX) port on the local equipment to the receive (RX) port on the peer equipment, and vice versa.
-

After the switch is installed, connect the switch to other equipment according to the following steps:

- (1) Connect the power cord delivered with the switch to the power strip.
- (2) Connect the RJ45 connector of a twisted pair to an Ethernet port on the switch, and the other end to downlink equipment.
- (3) Insert an optical transceiver into the optical port first according to the panel identification. Then connect a single-mode fiber (SMF) or multimode fiber (MMF) to the corresponding optical transceiver, during which the transmitting and receiving ends of the optical cable should be distinguished.

3.5 Bundling Cables

3.5.1 Precautions

- Bundle the power cord and other cables in an esthetically pleasing way.
- Make sure that the optical cables at the connectors have natural bends or bends of large radius.
- Do not bind optical cables and twisted pairs too tightly, as this may press the cables and affect their service life and transmission performance.

3.5.2 Bundling Procedure

- (1) Bind the drooping part of the optical cables and twisted pairs, and lead them to both sides of the chassis for convenience.
- (2) On both sides of the chassis, fasten the optical cables and twisted pairs to the cable management ring or cabling chute.
- (3) Bind the power cord closely along the bottom of the chassis, in a straight line wherever possible.

3.6 Verifying Installation

Caution

Please turn off the power to avoid personal injury and damage to components caused by incorrect connection.

- Verify that the grounding wire is connected.
- Verify that the cables including power cords are properly connected.
- Verify that cables connected to ports are routed indoors.
- Verify that the surge protection socket and Ethernet port arrester are installed, if outdoor cabling exists.
- Verify that there is a minimum clearance of 10 cm (3.94 in.) around the switch.

4 Commissioning

4.1 Power-on

- (1) Checklist Before Power-on
 - The switch is properly grounded.
 - The power cord is properly connected.
 - The power supply voltage meets the requirement of the switch.
- (2) Checklist After Power-on (Recommended)
 - The switch LEDs are in the normal state.
 - Service ports can forward data properly.

4.2 Logging In to the Management Interface

- (1) Connect a PC to an Ethernet port on the switch through an Ethernet cable.
- (2) Set the IP address of the PC to 10.44.77.XXX (Range: 1–254, excluding 200).

Figure 4-1 Changing the IP Address

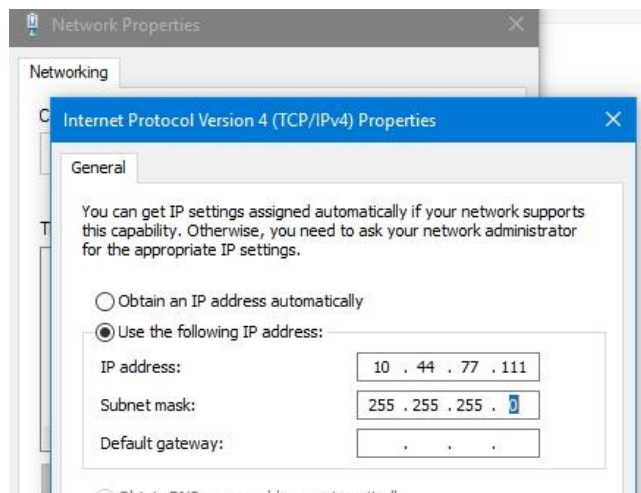

- (3) Open a browser, enter 10.44.77.200 in the address bar, and press Enter. On the login page, set a password and log in.
- (4) Perform equipment commissioning and configuration based on service requirements.

Note

For security purposes, you are advised to change the password regularly.

5 Troubleshooting

5.1 General Troubleshooting Flowchart

Note

You can determine whether each checking item in the process is normal based on the information provided in the previous chapters "Overview" and "Installing the Switch."

Figure 5-1 General Troubleshooting Flowchart

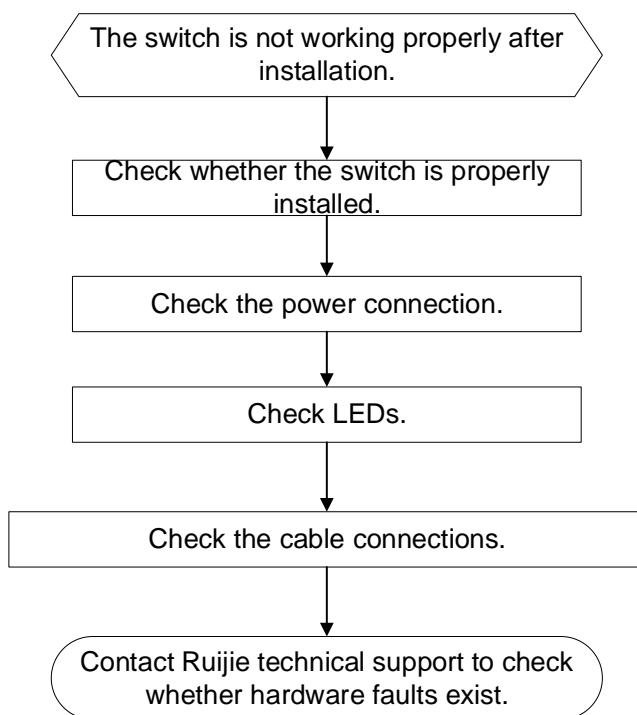

5.2 Common Faults

Table 5-1 Common Faults and Troubleshooting

Symptom	Possible Cause	Suggested Action
The system status LED is off after the switch is powered on.	No power is supplied to the switch or the power cord is loosely connected.	Check whether the power socket in the equipment room is normal and whether the power cord is loosely connected to the switch.
An RJ45 port is disconnected or a frame	The twisted pair is not connected properly.	Replace the twisted pair.

Symptom	Possible Cause	Suggested Action
sending/receiving error occurs.	The cable length exceeds 100 m (328.08 ft.).	Use an optical cable for data transmission or connect to an intermediate switch for relay.
	The port is specially configured and does not work in the same mode as that of the interconnected switch.	Check whether the port is configured to work in the same mode as that of the interconnected switch.
An optical port is not reachable.	The transmit and receive ends are connected incorrectly.	Exchange the transmit and receive ends of the optical cable.
	The types of the interconnected optical transceivers do not match.	Replace with one compatible optical transceiver.
	The optical cable type does not meet the requirements.	Replace the optical cable with a qualified one.
	The optical cable length is beyond the allowed length marked on the optical transceiver.	Use an optical cable with the required length.
	The optical cable or connector is contaminated.	Clean the connector with a lint-free cloth or a cleaning pen.
The login password cannot be retrieved.	The password is forgotten, and the equipment is not connected to the network or Ruijie Cloud.	Press and hold the Reset button to restore to factory settings.
	If the equipment is connected to Ruijie Cloud or a network, its login password is updated to the project or global management password.	If the equipment is connected to the cloud, log in using the project management password. If the equipment is connected to a network, log in using the global management password.
The Ethernet ports are transmitting and receiving frames normally, but their LEDs are off.	<p>The status of the Ethernet port LEDs is incorrectly displayed.</p> <p>The DIP switch is set to LED mode 2. As a result, the Ethernet port LEDs display the PoE status, but PoE is disabled on the ports.</p>	Set the DIP switch to LED mode 1 so that the Ethernet port LEDs display the data receiving and sending status.

6 Appendix

6.1 Connectors and Media

6.1.1 100r100Or1000BASE-T Port

The 10/100/1000BASE-T port supports auto-negotiation for 10 Mbps, 100 Mbps, and 1000 Mbps connections and also supports auto MDI/MDIX Crossover.

Compliant with IEEE 802.3ab, a 1000BASE-T port connects to a 100-ohm Category 5 (CAT5) or Category 5 Enhanced (CAT5e) Unshielded Twisted Pair (UTP), or recommended Shielded Twisted Pair (STP) cable with a maximum distance of 100 m (328.08 ft.).

The 1000BASE-T port requires that all four pairs of wires be connected for data transmission. [Figure 6-1](#) shows twisted pair connections for the 1000BASE-T port.

Figure 6-1 Twisted Pair Connections for a 1000BASE-T Port

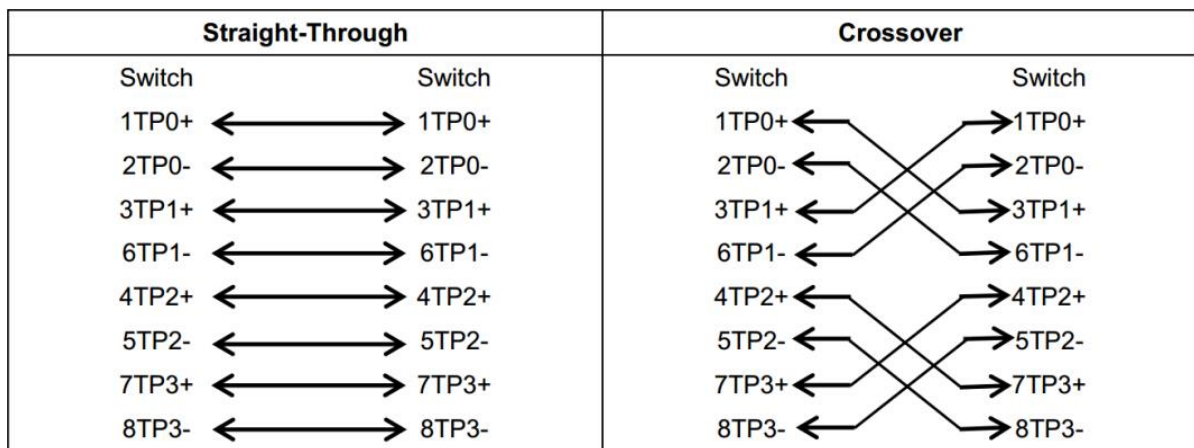

In addition to cables with the above-mentioned specifications, the 10/100BASE-T port can also be connected using 100-ohm CAT3, CAT4, and CAT5 cables at 10 Mbps or using 100-ohm CAT5 cables with a maximum distance of 100 m (328.08 ft.). The following table shows pin assignments for a 10/100BASE-T port.

Table 6-1 10/100BASE-T Pin Assignment

Pin	Socket	Plug
1	Input Receive Data+	Output Transmit Data+
2	Input Receive Data-	Output Transmit Data-
3	Output Transmit Data+	Input Receive Data+
6	Output Transmit Data-	Input Receive Data-
4, 5, 7, and 8	Not Used	Not Used

The following table shows wiring of straight-through and crossover cables for a 10/100BASE-T port.

Figure 6-2 Twisted Pair Connections for a 10/100BASE-T Port

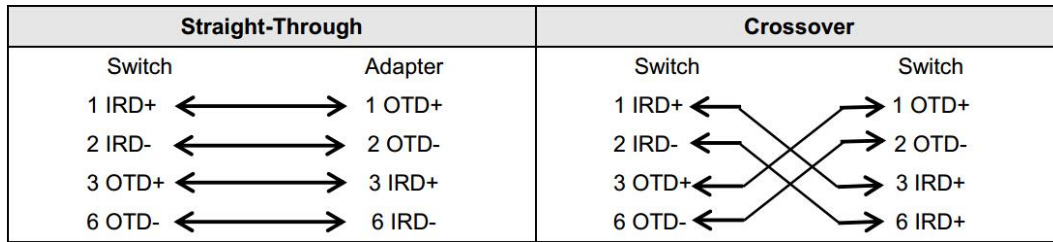

6.1.2 Optical Cable Connection

Select a single-mode fiber (SMF) or multimode fiber (MMF) for connections based on the type of the optical transceiver inserted into an optical port. [Figure 6-3](#) shows the connections.

Figure 6-3 Connecting the Optical Cables

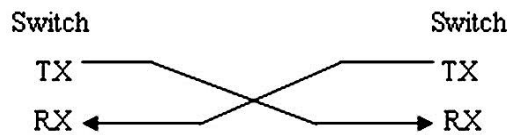

6.2 SFP Transceivers

Ruijie provides SFP transceivers (mini-GBIC) based on the port types. You can select one that suits your specific needs. In addition to the following 1GE SFP transceivers, the 1GE copper transceiver Mini-GBIC-GT is also supported. This document provides models and technical specifications of some 1GE SFP transceivers for reference. For details about the technical specifications, see *Ruijie Transceiver Installation and Reference Guide*.

Table 6-2 1GE Mini-GBIC (SFP) Models and Technical Specifications

Model	Wavelength (nm)	Fiber Type	DDM Supported (Yes/No)	Transmit Power (dBm)		Receive Power (dBm)	
				Min	Max	Min	Max
MINI-GBIC-SX-MM850	850	MMF	Yes	-9	-3	-20	-3
MINI-GBIC-LX-SM1310	1310	SMF	Yes	-9	-3	-26	0
GE-SFP-LH40-SM1310-BIDI	1310TX/1550RX	SMF	Yes	-3	3	-25	0
GE-SFP-LH40-SM1550-BIDI	1550TX/1310RX	SMF	Yes	-3	3	-25	0

GE-SFP-LX20-SM1310-BIDI	1310TX/1550RX	SMF	Yes	-8	-3	-23	-3
GE-SFP-LX20-SM1550-BIDI	1550TX/1310RX	SMF	Yes	-8	-3	-23	-3
MINI-GBIC-LH40-SM1310	1310	SMF	Yes	-5	0	-25	-3
MINI-GBIC-ZX80-SM1550	1550	SMF	Yes	-3	3	-26	-3
GE-SFP-LX03-SM1310-BIDI-I	1310TX/1550RX	SMF	Yes	-9	-3	-22	-3
GE-SFP-LX03-SM1550-BIDI-I	1550TX/1310RX	SMF	Yes	-9	-3	-22	-3
SFP-MM850	850	MMF	Yes	-9.5	-3	-17	-3
SFP-SM1310	1310	SMF	Yes	-9	-3	-20	-3

Table 6-3 1GE SFP Copper Transceivers

Standard	1000BASE-T SFP Module	DDM Supported (Yes/No)
1000BASE-T	Mini-GBIC-GT	No

Table 6-4 Cabling Specifications of SFP Transceivers

SFP Transceiver Model	Port Type	Fiber Type	Core Size (μm)	Max Cabling Distance
SFP-SM1310	LC	SMF	9/125	10 km (6.21 miles)
MINI-GBIC-LX-SM1310	LC	SMF	9/125	10 km (6.21 miles)
GE-SFP-LH40-SM1310-BIDI	LC	SMF	9/125	40 km (24.85 miles)
GE-SFP-LH40-SM1550-BIDI	LC	SMF	9/125	40 km (24.85 miles)
GE-SFP-LX20-SM1310-BIDI	LC	SMF	9/125	20 km (12.43 miles)
GE-SFP-LX20-SM1550-BIDI	LC	SMF	9/125	20 km (12.43 miles)
MINI-GBIC-LH40-SM1310	LC	SMF	9/125	40 km (24.85 miles)

SFP Transceiver Model	Port Type	Fiber Type	Core Size (µm)	Max Cabling Distance
				miles)
MINI-GBIC-ZX80-SM1550	LC	SMF	9/125	80 km (49.71 miles)
GE-SFP-LX03-SM1310-BIDI-I	LC	SMF	9/125	3 km (1.86 miles)
GE-SFP-LX03-SM1550-BIDI-I	LC	SMF	9/125	3 km (1.86 miles)
MINI-GBIC-SX-MM850	LC	MMF	62.5/125	275 m (902.23 ft.)
			50/125	550 m (1,804.46 ft.)
SFP-MM850	LC	MMF	62.5/125	275 m (902.23 ft.)
			50/125	550 m (1,804.46 ft.)
Mini-GBIC-GT	RJ45 Ethernet cable	CAT5 or better UTP or STP cable		100 m (328.08 ft.)

⚠ Caution

- For optical transceivers with a cabling distance of no less than 40 km (24.85 miles), install an optical attenuator to avoid overload on an optical receiver when using short-distance SMFs.
- An optical transceiver is a laser transmitter. Do not look into the light source to prevent it from burning your eyes.
- To keep the optical transceiver clean, make sure that the unused ports remain capped.

Table 6-5 BIDI Optical Transceiver Pairing

Rate/Distance	Pairing Model
1000 Mbps/3 km (1.86 miles)	<ul style="list-style-type: none"> ● GE-SFP-LX03-SM1310-BIDI-I ● GE-SFP-LX03-SM1550-BIDI-I
1000 Mbps/20 km (12.43 miles)	<ul style="list-style-type: none"> ● GE-SFP-LX20-SM1310-BIDI ● GE-SFP-LX20-SM1550-BIDI
1000 Mbps/40 km (24.85 miles)	<ul style="list-style-type: none"> ● GE-SFP-LH40-SM1310-BIDI ● GE-SFP-LH40-SM1550-BIDI

⚠ Caution

BIDI optical transceivers must be used in pairs. For example, if GE-SFP-LX20-SM1310-BIDI is used at one end, GE-SFP-LX20-SM1550-BIDI must be used at the other end.

6.3 Lightning Protection

6.3.1 Installing the AC Power Arrester (Power Strip with Surge Protection)

When an alternating current (AC) power cord is introduced from outdoors and directly connected to the AC power port of the switch, the power port must be connected to an external power arrester to safeguard the switch against lightning strikes. The power arrester can be fixed on the rack, workbench, or wall in the equipment room by using cable ties and screws. AC power enters the power arrester before entering the switch.

Figure 6-4 Power Arrester

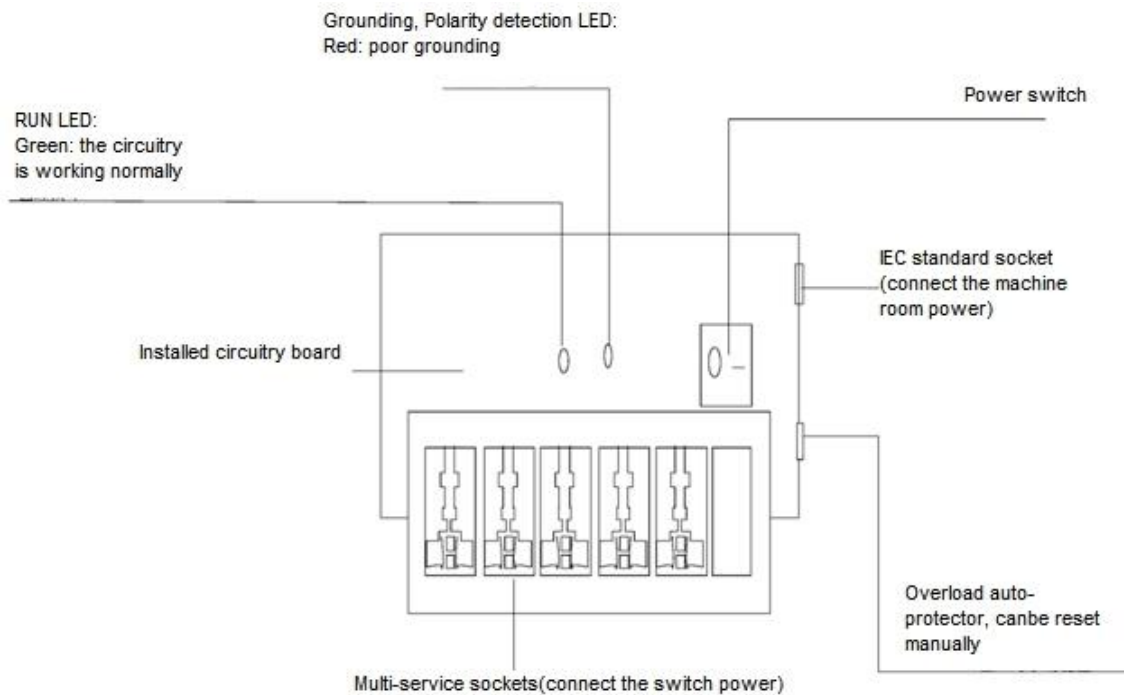

⚠ Caution

The power arrester is not delivered with the equipment. Please purchase it based on actual requirements.

Precautions during the installation:

- Make sure that the PE terminal of the power arrester is well grounded.
- After the AC power plug of the switch is connected to the socket of the power arrester, the lightning protection function is implemented only if the running status LED is green and the alarm LED is off.
- If the alarm LED on the power arrester is red, check whether it is caused by a poor grounding connection or

by the reversed connection of the neutral and live wires. The detection method is as follows: Use a multimeter to measure the polarity of the power arrester when the alarm LED is red. If the neutral wire is on the left and the live wire is on the right (facing the socket), the PE terminal of the power arrester is not grounded. If not, the polarity of the power arrester should be reversed. In this case, open the power arrester and reverse its polarity. If the alarm LED is still red, the PE terminal of the power arrester is not grounded.

6.3.2 Installing the Ethernet Port Arrester

Please connect an Ethernet port arrester to the switch to prevent the damage by lightning strikes before connecting an outdoor Ethernet cable to the switch.

- Tools: Phillips screwdriver or flat-blade screwdriver, multimeter, and diagonal pliers
- Installation steps
 - a Tear one side of the protective paper for the double-sided adhesive tape and paste the tape to the enclosure of the Ethernet port arrester. Tear the other side of the protective paper for the double-sided adhesive tape and paste the Ethernet port arrester to the switch enclosure. The paste position for the Ethernet port arrester should be as close to the grounding lug of the switch as possible.
 - b Based on the distance between the grounding lug of the switch and the Ethernet port arrester, cut the grounding cable of the Ethernet port arrester and firmly tighten the grounding cable to the grounding lug of the switch.
 - c Use a multimeter to check whether the grounding cable for the arrester is in good contact with the grounding lug and the enclosure of the switch.
 - d Connect the Ethernet port arrester by using an adapter cable (note that the external Ethernet cable is connected to the IN end, while the adapter cable connected to the switch is connected to the OUT end) and check whether the module LED is normal.
 - e Use a nylon cable tie to bind the cables.

Figure 6-5 Installing an Ethernet Port Arrester

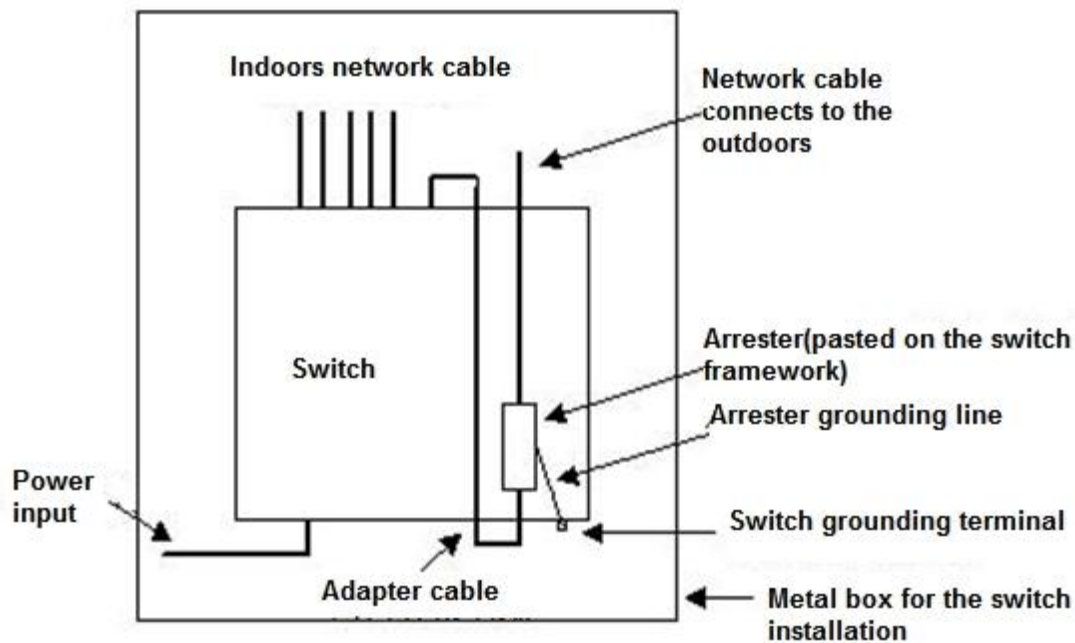

⚠ Caution

- The Ethernet port arrester is only for a 10 Mbps, 100 Mbps, or 1000 Mbps RJ45 port.
- The Ethernet port arrester is not delivered with the equipment. Please purchase it based on actual requirements. The user manual for Ethernet port arresters contains technical parameters and maintenance and installation instructions. Carefully read this manual during installation.

Pay attention to the following situations during the actual installation to avoid influencing the performance of an Ethernet port arrester:

- The arrester is incorrectly connected to the cables. Connect the external Ethernet cable to the IN end and connect the Ethernet port of the switch to the OUT end.
- The Ethernet port arrester is incorrectly grounded. The grounding cable of the arrester should be as short as possible to ensure that it is in good contact with the grounding lug of the switch. Use a multimeter to confirm the contact condition after grounding.
- Not all Ethernet ports are installed with Ethernet port arresters. If outdoor Ethernet cables connect the switch ports to the peer equipment, Ethernet port arresters need to be installed on all the ports for the purpose of lightning protection.

6.4 Recommended Cabling

When the switch is installed in a standard 19-inch cabinet, secure the cables around the cable management brackets. Top cabling or bottom cabling is adopted according to the actual situation in the equipment room. All adapted connectors should be placed at the bottom of the rack in an orderly manner instead of outside the rack that is easy to touch. Power cords are routed beside the rack. Top cabling or bottom cabling is adopted according

to the actual situation in the equipment room, such as the positions of the DC power distribution box, AC socket, or lightning protection box.

6.4.1 Requirement for the Minimum Bend Radius of Cables

- The bend radius of a fixed power cord, Ethernet cable, and flat cable should be over five times greater than their respective external diameters. The bend radius of these cables that are often bent or plugged should be over seven times greater than their respective external diameters.
- The bend radius of a fixed common coaxial cable should be over seven times greater than its external diameter. The bend radius of these cables that are often bent or plugged should be over 10 times greater than their respective external diameters.
- The minimum bend radius of a high-speed cable, such as an SFP+ cable, should be 5 times the overall diameter of the cable. If the cable is constantly bent, plugged or unplugged, the bend radius should be 10 times the overall diameter.
- The minimum bend radius of optical cables should meet the following requirements.
 - The diameter of the optical cable tray should be no less than 25 times greater than that of the optical cable.
 - When an optical cable is moved, its bend radius should be no less than 20 times greater than its diameter.
 - During cabling of an optical cable, its bend radius should be no less than 10 times greater than its diameter.

6.4.2 Precautions for Cable Bundling

- Before cables are bundled, mark labels and stick the labels to cables wherever appropriate.
- Cables should be neatly and properly bundled in the rack without twisting or bending, as shown in [Figure 6-6](#).

Figure 6-6 Bundling Cables (1)

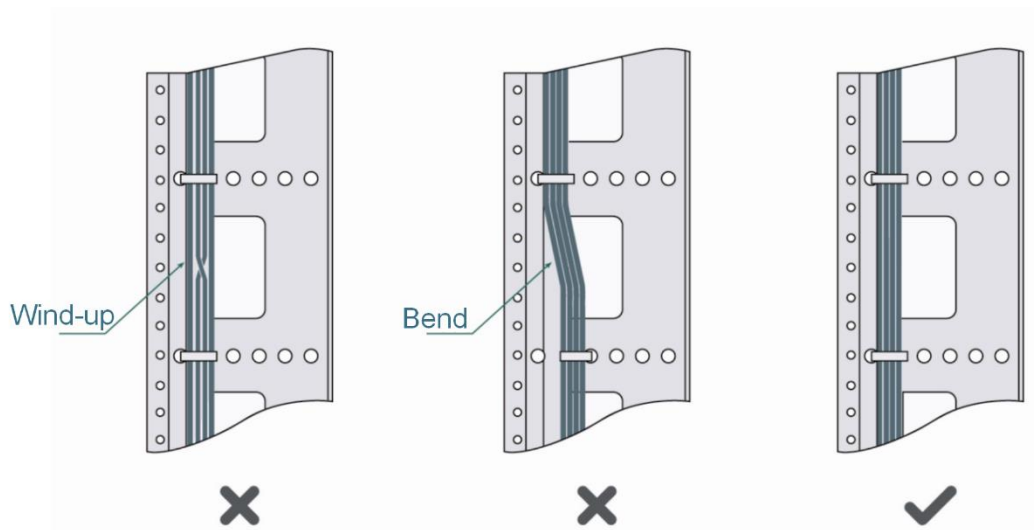

- Cables of different types (such as power cords, signal cables, and grounding wires) should be separated in cabling and bundling. Mixed bundling is not allowed. When they are close to each other, you are advised to

adopt crossover cabling. In the case of parallel cabling, maintain a minimum distance of 30 mm (1.18 in.) between power cords and signal cables.

- The cable management brackets and cabling troughs inside and outside the rack should be smooth without sharp corners.
- The metal holes traversed by cables should have a smooth and fully rounded surface or an insulated lining.
- Use cable ties to bundle cables properly. Please do not connect two or more cable ties to bundle cables.
- After bundling up cables with cable ties, cut off the remaining part. The cut should be smooth and trim without sharp corners, as shown in [Figure 6-7](#).

Figure 6-7 Bundling Cables (2)

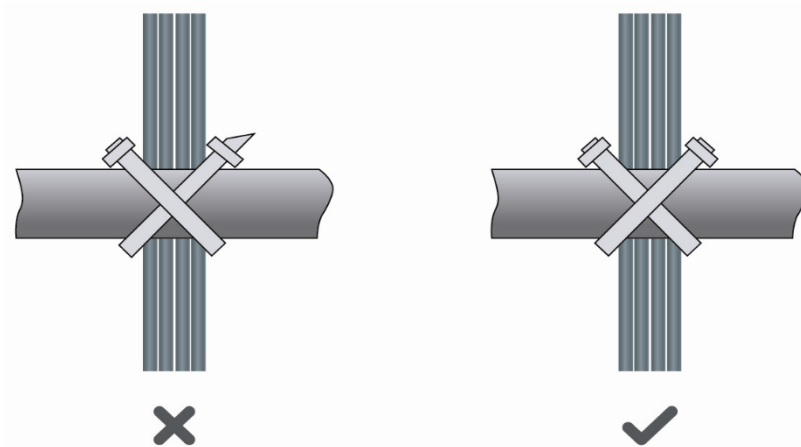

- When cables need to be bent, bundle them first but do not tie cables within the bend. Otherwise, stress may be generated on the cables and cause the wires inside to break, as shown in [Figure 6-8](#).

Figure 6-8 Bundling Cables (3)

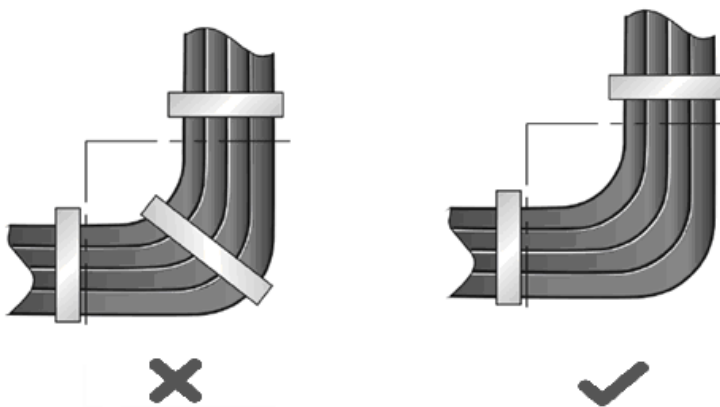

- Cables not to be assembled or the remaining parts of cables should be folded and placed in a proper position of the rack or cable management trough. The proper position refers to a position that does not affect the equipment running or damage the equipment or cables.
- Power cords must not be bundled on the guide rails of moving parts.
- The power cords connecting moving parts such as door grounding wires should be reserved with some

excess after being assembled to avoid suffering tension or stress. When a moving part reaches the installation position, the remaining cable part should not touch heat sources, sharp corners, or sharp edges. If heat sources must be touched, high-temperature cables should be used.

- When using screw threads to secure a cable lug, ensure that the bolt or screw is properly tightened and take measures to prevent it from loosening, as shown in [Figure 6-9](#).

Figure 6-9 Fastening Cables

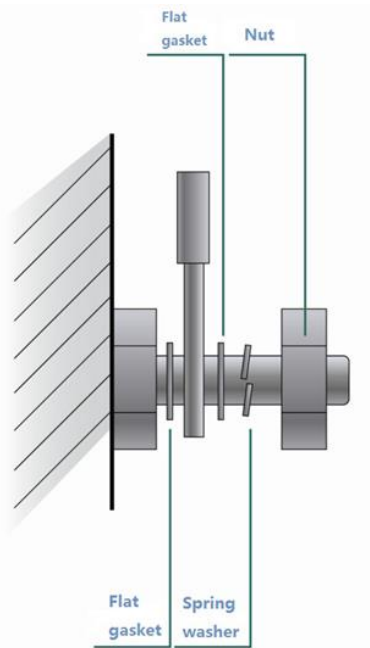

- Hard power cords should be secured near the cable termination area to prevent stress on the cable termination area and cables.
- Do not use tapping screws to secure cable lugs.
- Power cords of the same type and in the same cabling direction should be bundled up into cable bunches, with cables in cable bunches clean and straight.
- Bundle cables by using cable ties according to the following table.

Cable Bunch Diameter	Bundling Spacing
10 mm (0.39 in.)	80–150 mm (3.15–5.91 in.)
10–30 mm (0.39–1.18 in.)	150–200 mm (5.91–7.87 in.)
30 mm (1.18 in.)	200–300 mm (7.87–11.81 in.)

- Do not tie cables or bundles in a knot.
- For wiring terminal blocks (such as circuit breakers) with cord end terminals, the metal part of the cord end terminal should not be exposed outside the terminal block when assembled.

6.5 Site Selection

- The equipment room should be at least 5 km (3.11 miles) away from heavy pollution sources, such as smelters, coal mines, and thermal power plants. The equipment room should be at least 3.7 km (2.30 miles) away from medium pollution sources, such as the chemical factory, rubber factory, and electroplating factory. The equipment room should be at least 2 km (1.24 miles) away from light pollution sources, such as the food factory and leather plant. If the pollution source is unavoidable, the equipment room should be located on the windward side of the pollution source perennially with advanced protection.
- The equipment room should be at least 3.7 km (2.30 miles) away from the sea or salt lake. Otherwise, the equipment room must be sealed, with an air conditioner installed for temperature control. Saline soil cannot be used for construction. Otherwise, you should select equipment with advanced protection against severe environments.
- Do not build the equipment room in the proximity of livestock farms. Otherwise, the equipment room should be located on the windward side of the pollution source perennially. The previous livestock house or fertilizer warehouse cannot be used as the equipment room.
- The equipment room should be firm enough to withstand severe weather conditions such as windstorms, heavy rain, and dense dust. If the dust is unavoidable, keep the door and window away from the pollution source.
- The equipment falls into Class A. Therefore, the equipment room should be located away from the residential area. Otherwise, the equipment room should meet construction specifications to avoid noise and radio interference.
- Make sure the air vent of the equipment room is away from the sewage pipe, septic tank, and sewage treatment tank. Keep the equipment room under positive pressure to prevent corrosive gas from entering the equipment room to corrode components and circuit boards.
- Keep the equipment room away from industrial boilers and heating boilers.
- The equipment room should be on the second floor or higher. Otherwise, the equipment room floor should be 600 mm (23.62 in.) higher than the highest flood level ever recorded.
- Make sure no cracks or holes exist in the wall and floor. If there are cable entries in the wall or window, take proper sealing measures. Ensure that the wall is flat, wear-resistant, and dust-free, meeting standards for flame resistance, soundproofing, heat absorption, dust reduction, and electromagnetic shielding.
- Keep the door and the window closed to make the equipment room sealed.
- You are advised to use the steel door for soundproofing.
- Do not use sulfur-containing materials.
- Keep the air conditioner from blowing wind straight toward the equipment or blowing water drops from the window or air vent toward the equipment.

Contents

1 Overview	4
1.1 About the RG-ES224GC2MS	4
1.2 Equipment Appearance	4
1.2.1 Front Panel.....	4
1.2.2 Rear Panel	5
1.2.3 LEDs	6
1.3 Cooling.....	6
1.4 Technical Specifications	6
2 Preparing for Installation	9
2.1 Package Contents.....	9
2.2 Safety Guidelines.....	9
2.2.1 General Precautions	9
2.2.2 Chassis-Lifting Guidelines	10
2.2.3 Electricity Safety	10
2.2.4 Preventing ESD Damage.....	11
2.2.5 Laser Safety	11
2.3 Site Requirements	12
2.3.1 Floor Loading	12
2.3.2 Airflow.....	12
2.3.3 Space	12
2.3.4 Temperature and Humidity.....	12
2.3.5 Cleanliness.....	12

2.3.6 Grounding	13
2.3.7 Preventing Electromagnetic Interference	14
2.3.8 Surge Protection	14
2.3.9 Installation Site.....	14
2.4 Rack Requirements	14
2.5 Tools	15
3 Installing the Switch	16
3.1 Before You Begin.....	16
3.2 Installing the Switch	16
3.2.1 Rack Mount.....	16
3.2.2 Workbench Mount.....	17
3.3 Grounding the Equipment.....	18
3.4 Connecting Cables.....	19
3.5 Bundling Cables.....	19
3.5.1 Precautions	19
3.5.2 Bundling Procedure	19
3.6 Verifying Installation.....	19
4 Commissioning.....	20
4.1 Power-on.....	20
4.2 Logging In to the Management Interface.....	20
5 Troubleshooting.....	21
5.1 General Troubleshooting Flowchart	21
5.2 Common Faults.....	21
6 Appendix.....	23

6.1 Connectors and Media.....	23
6.1.1 10Or100Or1000BASE-T Port	23
6.1.2 Optical Cable Connection	24
6.2 SFP Transceivers	24
6.3 Lightning Protection	27
6.3.1 Installing the AC Power Arrester (Power Strip with Surge Protection)	27
6.3.2 Installing the Ethernet Port Arrester	28
6.4 Recommended Cabling	29
6.4.1 Requirement for the Minimum Bend Radius of Cables	30
6.4.2 Precautions for Cable Bundling	30
6.5 Site Selection	33

1 Overview

1.1 About the RG-ES224GC2MS

The RG-ES224GC2MS Ethernet switch provides 24 10/100/1000BASE-T ports, two 1GE/2.5GE SFP ports, one Reset button, and several LEDs on the front panel, along with a AC power port and a grounding stud on the rear panel.

Figure 1-1 RG-ES224GC2MS Appearance



Note

- 2.5GE SFP port: Supports 2.5GE and 1GE SFP optical transceivers (not compatible with 100 Mbps optical cables).
- 10/100/1000BASE-T port: Supports auto-negotiation at 10 Mbps, 100 Mbps, and 1000 Mbps.

1.2 Equipment Appearance

1.2.1 Front Panel

Figure 1-2 Front Panel of the RG-ES224GC2MS

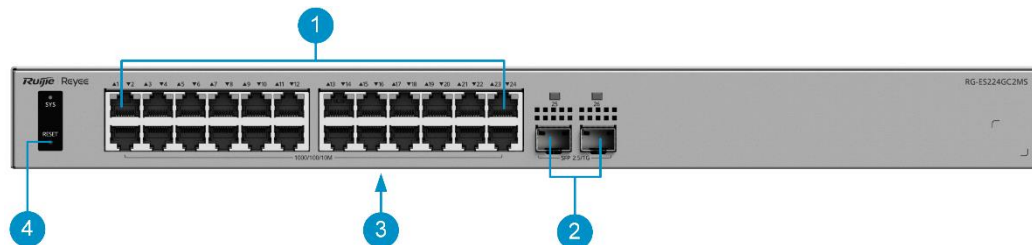

Table 1-1 Components on the Front Panel

No.	Component	Silkscreen	Description
1	RJ45 port	1000/100/10M	10/100/1000BASE-T ports

No.	Component	Silkscreen	Description
2	SFP port	SFP 2.5/1G	1GE/2.5GE SFP port, supporting 1GE/2.5GE SFP transceiver (hot-swappable)
3	Nameplate	-	It is located at the bottom of the switch.
4	Reset button	RESET	<ul style="list-style-type: none"> ● Press and hold the button for less than 2 seconds. The switch is reset. ● Press and hold the button for 2–5 seconds. No action is performed. ● Press and hold the button for more than 5 seconds, and release the button until the system status LED starts blinking to restore factory settings and restart the switch.

Note

For details about LEDs on the front panel, see "LEDs."

1.2.2 Rear Panel

Figure 1-3 Rear Panel of the RG-ES224GC2MS

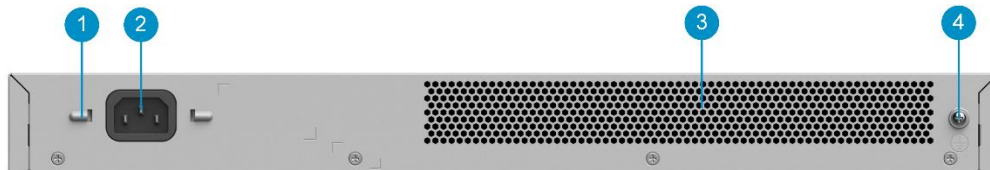

Table 1-2 Components on the Rear Panel

No.	Component	Description
1	Power cable spring clip hole	Secures the power cord retention clip to the holes.
2	Power port	Indicates a three-pin power port used for AC power connection.
3	Ventilation openings	Used for heat dissipation of the switch.
4	Grounding stud	Used to connect the switch to the ground.

1.2.3 LEDs

Figure 1-4 RG-ES224GC2MS LEDs

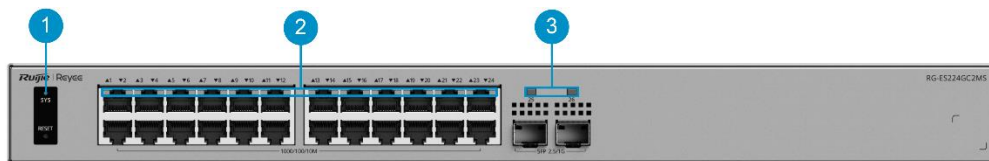

Table 1-3 LEDs

No.	Component	Silkscreen	Description
1	System status LED	SYS	<ul style="list-style-type: none"> ● Off: The switch is not powered on. ● Slow blinking green (0.5 Hz): The switch is operating normally but is not connected to Ruijie Cloud. ● Fast blinking green (10 Hz): The switch is upgrading or restarting, and is temporarily unavailable. ● Solid green: The switch is operating normally and connected to Ruijie Cloud. ● Slow blinking red (0.5 Hz): A loop occurs on the switch with loop guard enabled.
2	RJ45 port LED	1–24	<ul style="list-style-type: none"> ● Off: The port is not connected. ● Solid green: The port is operating at 1000 Mbps, 100 Mbps, or 10 Mbps, but is not receiving or sending data. ● Blinking green: The port is operating at 1000 Mbps, 100 Mbps, or 10 Mbps, and is receiving or sending data.
3	SFP port LED	25, 26	<ul style="list-style-type: none"> ● Off: The port is not connected. ● Solid green: The port is operating at 1000 Mbps or 2500 Mbps, but is not receiving or sending data. ● Blinking green: The port is operating at 1000 Mbps or 2500 Mbps, and is receiving or sending data.

1.3 Cooling

The RG-ES224GC2MS adopts fanless design and uses natural cooling. To ensure that the equipment works properly in the specified environment, a minimum clearance of 10 cm (3.94 in.) must be maintained around the equipment for air circulation and ventilation.

1.4 Technical Specifications

Warning

- This equipment is not suitable for use in locations where children are likely to be present.
- Operation of this equipment in a residential environment could cause radio interference.

Table 1-4 Technical Specifications

Parameter Type	Parameter Name	RG-ES224GC2MS
System Specifications	Forwarding rate	43.15 Mpps
	Switching capacity	58 Gbps(bit/s)
	Flash memory	8 MB
Port Specifications	Total number of optical ports	2
	Total number of RJ45 ports	24
	Number of 10/100/1000BASE-T ports	24
	Reset button	1
	LEDs	1 x system status LED 24 x Ethernet port LEDs 2 x SFP port LEDs
Power Supply and Consumption	Power supply	Fixed power supply
	Power input	220 V AC power supply: <ul style="list-style-type: none"> ● Rated input voltage: 100 V AC to 240 V AC, 50 Hz to 60 Hz ● Maximum input voltage: 90 V AC to 264 V AC, 47 Hz to 63 Hz ● Rated input current: 0.6 A
	Maximum power consumption	18 W
Dimensions and Weight	Product dimensions (W x D x H)	440 mm x 165 mm x 44 mm (17.32 in. x 6.50 in. x 1.73 in.)
	Weight	1.74 kg (3.84 lbs) (without packaging materials)
	Shipping weight	2.59kg (5.71 lbs)
	Casing	Metal
Interface	EEE	Yes
	Mounting options	Rack/Desk

Parameter Type	Parameter Name	RG-ES224GC2MS
Environment and Reliability	Hot swapping of cables	Hot swapping supported by the service port and power connector
	Fan	Fanless design
	Cooling	Natural cooling
	MTBF	200,000 hours
	ESD protection	Air discharge: 8 kV Contact discharge: 6 kV
	Surge protection	Service port: ± 6 kV for common mode Power connector: ± 6 kV for common mode and ± 6 kV for differential mode
	Operating temperature	0°C to 40°C (32°F to 104°F)
	Storage temperature	-40°C to +70°C (-40°F to +158°F)
	Operating humidity	10% RH to 90% RH (non-condensing)
	Storage humidity	5% RH to 95% RH (non-condensing)
	Altitude	-500 m to +5,000 m (-1,640.42 ft. to +16,404.20 ft.)
Certification and Regulatory Compliance	EMC	EN 55032 EN 61000-3-2 EN 61000-3-3 EN 55035 EN 300 386
	Safety compliance	EN 62368-1 IEC 62368-1
	Certification	CE, CB

2 Preparing for Installation

2.1 Package Contents

Table 2-1 Package Contents

No.	Item	Quantity
1	RG-ES224GC2MS switch	1
2	Rubber pad	4
3	User Manual	1
4	Warranty Card	1
5	M4 x 8 mm cross recessed countersunk head screw	6
6	Rack-mount bracket	2
7	Power cord retention clip	1
8	Power cord	1

Note

The package contents are subject to the purchase contract, and actual delivery may vary. Please check the items carefully against the package contents or purchase contract. If you have any questions, please contact the distributor.

2.2 Safety Guidelines

Note

- To avoid personal injury or equipment damage, review the safety guidelines in this chapter before you begin the installation.
 - The following safety guidelines may not include all the potentially hazardous situations.
-

2.2.1 General Precautions

- Install the equipment in a standard 19-inch rack and ensure that the rack and power distribution system are properly grounded.
- Never operate the equipment in a wet environment, and avoid any liquids inside it. Keep the chassis clean and dust-free.
- Keep the equipment away from heat sources.
- Keep the equipment away from walk areas.
- During installation and maintenance, do not wear loose clothing or ornament that may get caught in the

chassis.

- Keep tools and accessories away from walk areas.

2.2.2 Chassis-Lifting Guidelines

- Avoid moving the equipment frequently.
- Turn off all power supplies and disconnect all cables before lifting or moving the equipment.
- Two or more people are required to lift the chassis. Keep balance and prevent personal injuries when lifting or moving the equipment.

2.2.3 Electricity Safety

Warning

- Any deviation from standard or improper electrical operations can result in accidents such as fires or electric shocks, potentially causing severe or even fatal harm to both individuals and equipment.
 - Direct or indirect touch through a wet object on high-voltage and mains supply can bring a fatal danger.
-
- Always observe the local regulations and standards. Only qualified personnel should be allowed to operate the equipment.
 - Carefully check the work area for potential hazards, including ungrounded power system, absent safety grounds, and damp floors.
 - Locate the emergency power-off switch in the room before installation. In the case of an accident, cut off the power supply immediately.
 - Never assume that power is connected to or disconnected from a circuit. Always check.
 - Select the right leakage protector (also called "leakage current switch" or "leakage current breaker") for the power supply system. This equipment automatically disconnects the power supply in the event of leakage and the risk of electric shock. A leakage protector should meet the following requirements:
 - The rated leakage action current of each leakage protector must be at least twice the total maximum leakage current of all connected power supplies.
Example:
If a system has 16 identical power supplies, each with a maximum leakage current of 3.5 mA:
Total leakage current = 16 x 3.5 mA = 56 mA
For a 30 mA leakage protector:
Maximum number of power supplies per protector = 30 mA/2/3.5 mA ≈ 4
Therefore, only four power supplies can be connected to one 30 mA leakage protector.
To support 16 power supplies, at least four 30 mA leakage protectors are required.
Always ensure:
Rated leakage operating current/2 > Total maximum leakage current of connected power supplies
 - The rated leakage non-action current of a leakage protector should be 50% of the leakage action current. If the non-action current value is too small, the high sensitivity level can cause the circuit to break, leading to power cutoff and service interruption, even if the leakage current value is normal.

For example, if a leakage protector has a rated leakage action current of 30 mA, the rated leakage non-action current should be 15 mA. The leakage protector will not activate unless the leakage current exceeds 15 mA.

⚠ Caution

- To ensure personal safety, each leakage protector in the system must have a rated leakage action current equal to or below 30 mA, which is the recognized safety threshold for human body current. If the total leakage current of the system exceeds twice the 30 mA limit, the system must be equipped with two or more leakage protectors to maintain safety.
 - The leakage current values vary with equipment. For the leakage current value of each equipment model, see "Technical Specifications."
-

2.2.4 Preventing ESD Damage

- Ensure that the chassis is connected to earth ground.
- Keep the site as dust free as possible.
- Maintain appropriate humidity conditions.
- Before installing any pluggable modules, wear an anti-ESD wrist strap and make sure that it is properly grounded.
- Avoid contact between the printed circuit boards and clothing. The anti-ESD wrist strap only protects the printed circuit boards from ESD voltages on the body. ESD voltages on clothing can still cause damage.

2.2.5 Laser Safety

The equipment supports various types of optical transceivers, which are Class 1 laser products.

Precautions:

- When an optical transceiver is working, ensure that its port is connected to an optical cable or covered by a dust cap to keep out dust and prevent it from burning your eyes.
- Do not stare into an optical port.

Figure 2-1 Laser Product ID

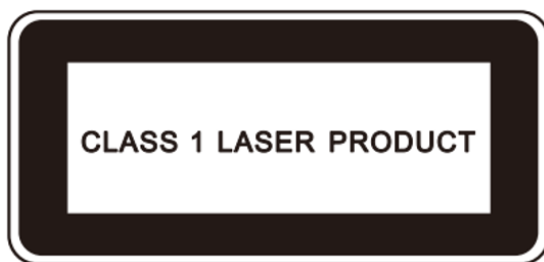

⚠ Caution

Do not approach or stare into an optical port under any circumstances. This may cause permanent damage to your eyes.

2.3 Site Requirements

The equipment must be installed indoors for normal operation and prolonged service life.

The installation site must meet the following requirements.

2.3.1 Floor Loading

Assess the combined weight of the equipment and its accessories, such as rack, chassis, and power modules, and verify that the floor under the rack can bear the weight.

2.3.2 Airflow

The equipment adopts natural cooling. Reserve a sufficient clearance around the equipment to ensure proper ventilation.

2.3.3 Space

You are advised to have a pathway of at least 0.8 m (2.62 ft.) wide in the equipment room. This space ensures that you can move the chassis and swap the modules easily.

Do not install the equipment against a wall. Instead, maintain a minimum clearance of 10 cm (3.94 in.) around the equipment for heat dissipation and equipment maintenance.

2.3.4 Temperature and Humidity

To ensure the normal operation and a prolonged service life of the equipment, maintain an appropriate temperature and humidity in the installation environment.

Prolonged exposure to inappropriate temperature and humidity conditions can cause damage to the equipment.

- In an environment with high relative humidity, insulating materials are prone to poor insulation or even electricity leakage.
- In an environment with low relative humidity, insulating gaskets may shrink, resulting in screw loosening.
- In a dry environment, static electricity is more likely to occur, posing a risk to the internal circuits of equipment.
- A high temperature can accelerate the aging process of insulation materials, greatly reducing the availability of the equipment and severely affecting its service life.

2.3.5 Cleanliness

Dust poses a significant hazard to the equipment. Dust on the enclosure causes electrostatic adhesion, leading to poor contact of the metallic joints. Electrostatic adhesion is more likely to occur in an indoor environment with relatively low humidity, not only affecting the service life of the equipment, but also causing communication faults.

The following table lists the requirements for dust concentration and particle size in the equipment room.

Table 2-2 Requirements for Dust

Particle Diameter	Unit	Concentration
≥ 0.5 μm	Particles/m ³	≤ 3.5 × 10 ⁶
≥ 5 μm	Particles/m ³	≤ 3.5 × 10 ⁶

Apart from dust, there are also requirements on the salt, acid, and sulfide in the air of the equipment room. These harmful substances will accelerate metal corrosion and component aging. Therefore, the equipment room should be properly protected against harmful gases, such as sulfur dioxide, hydrogen sulfide, nitrogen dioxide, and chlorine gas. The following table lists the limits on harmful gases.

Table 2-3 Requirements for Gases

Gas	Average (mg/m ³)	Maximum (mg/m ³)
Sulfur dioxide (SO ₂)	0.3	1.0
Hydrogen sulfide (H ₂ S)	0.1	0.5
Nitrogen dioxide (NO ₂)	0.5	1.0
Chlorine gas (Cl ₂)	0.1	0.3

Note

Average refers to the average value of harmful gases measured in a week. **Maximum** refers to the upper limit of harmful gases measured in a week for up to 30 minutes every day.

2.3.6 Grounding

A proper grounding system is crucial for ensuring stable and reliable operation, as well as preventing lightning strikes and interference. Carefully check the grounding conditions at the installation site according to the grounding requirements, and complete grounding properly based on the site situation.

- Safety Grounding

Ensure that the rack and power distribution system are securely grounded if the equipment uses the AC power supply. Otherwise, electric shocks may occur when the insulation resistance between the power module and the chassis decreases.

Caution

- The building should provide a protective ground connection to ensure that the equipment is connected to a protective ground.
 - Verify that the AC socket is reliably connected to the protective grounding system of the building. If not, a protective grounding wire should be used to connect the protective grounding lug of the AC socket to the protective grounding system of the building.
-

- Lightning Grounding

The lightning protection system is an independent system composed of a lightning rod, a downlead conductor, and a connector connected to the grounding system. The grounding system is typically used for power reference grounding and safety grounding of the rack. Lightning grounding is required only for facilities, and is not required for the equipment.

- EMC Grounding

Electromagnetic compatibility (EMC) grounding includes shielded grounding, filter grounding, noise and interference suppression, and level reference.

2.3.7 Preventing Electromagnetic Interference

- Take interference prevention measures for the power supply system.
- Keep the equipment away from the grounding system or lightning protection grounding system of the power facility.
- Keep the equipment far away from high-frequency current equipment such as high-power radio transmitting stations and radar launchers.
- Take electromagnetic shielding measures when necessary.

2.3.8 Surge Protection

Although the equipment can guard against lightning strikes, strong lightning strikes may still damage the equipment. Take the following surge protection measures:

- Ensure that the grounding wire of the rack is in good contact with the ground.
- Ensure that the neutral point of the AC power socket is in good contact with the ground.
- Install a power arrester in front of the power input end to enhance surge protection for the power supply.

2.3.9 Installation Site

Regardless of whether the equipment is installed in a rack or on a workbench, ensure that the following conditions are met:

- Maintain a proper clearance around the air inlets and outlets for heat dissipation.
- Install the equipment in a standard 19-inch rack. Alternatively, place the equipment on a clean workbench. The installation of air conditioners is recommended in hot areas.
- The installation site has a good cooling and ventilation system.
- The installation site is sturdy enough to support the weight of the chassis and its accessories.
- The installation site is properly grounded.

2.4 Rack Requirements

If you plan to install the equipment in a rack, ensure that the rack meets the following conditions.

- (1) Use a four-post 19-inch rack.
- (2) The left and right square-hole rack posts are 465 mm (18.31 in.) apart.

Figure 2-2 19-Inch Rack

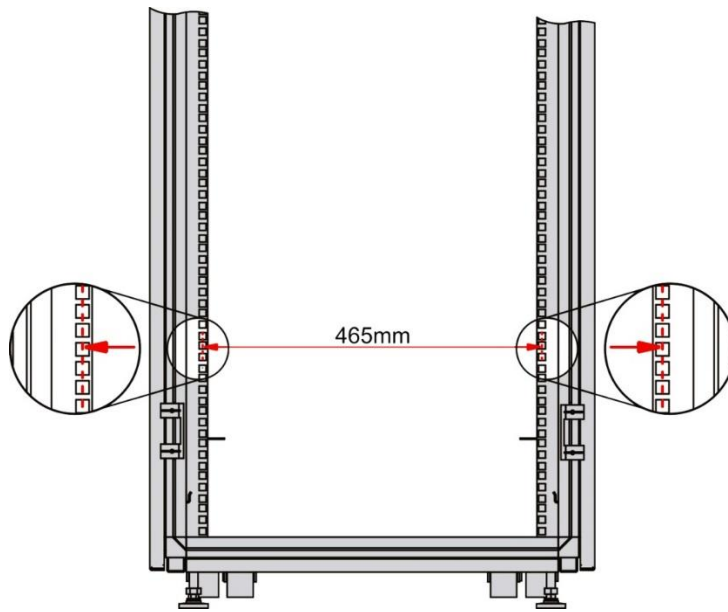

- (3) The square-hole rack post is at least 180 mm (7.09 in.) from the front door, and the front door is at most 25 mm (0.98 in.) thick. This ensures an available clearance of at least 155 mm (6.10 in.). The rack depth (distance between front and rear doors) is at least 1000 mm (39.37 in.).
- (4) The guide rails or tray can bear the weight of the equipment and its accessories.
- (5) The rack has a reliable grounding lug for the chassis to connect to earth ground.
- (6) The rack has a reliable ventilation system. The open area of front and rear doors is greater than 50%.

2.5 Tools

Table 2-4 Tools

Common Tools	Phillips screwdriver, cables, cage nuts, diagonal pliers, cable ties, and grounding wires
Dedicated Tools	Anti-ESD gloves, wire stripper, crimping pliers, RJ45 crimping pliers, and wire cutter
Meter	Multimeter

Note

The equipment is delivered without a toolkit. Prepare the preceding tools by yourself.

3 Installing the Switch

⚠ Caution

Before installing the equipment, ensure that guidelines and requirements in Chapter 2 have been met.

3.1 Before You Begin

- The installation site provides sufficient space for heat dissipation.
- The installation site meets the temperature and humidity requirements.
- The power supply is available at the installation site, and its current meets the requirements.
- The Ethernet cables have been deployed at the installation site.
- Locate the emergency power-off switch in the room before installation. In the case of an accident, cut off the power supply immediately.

3.2 Installing the Switch

3.2.1 Rack Mount

Install the RG-ES224GC2MS switch in a standard 19-inch rack. The installation steps are as follows:

- (1) Take out the M4 x 8 mm cross recessed countersunk head screws delivered with the switch. Attach a rack-mount bracket to each side of the switch and secure it with three screws.

Figure 3-1 Securing Rack-Mount Brackets

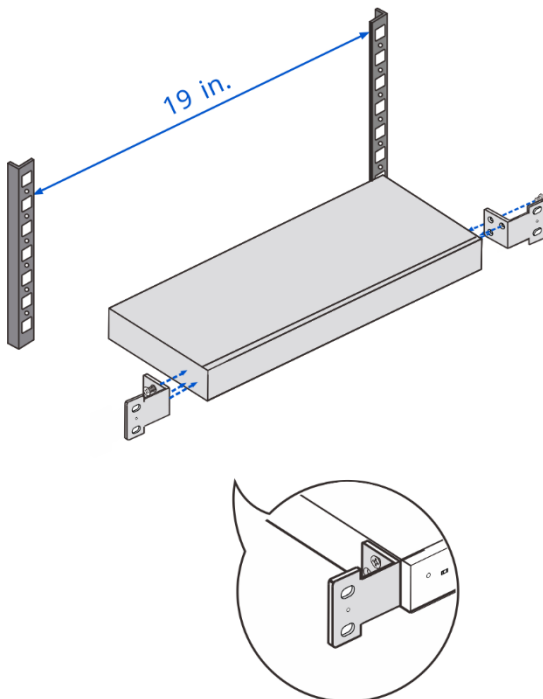

- (2) Horizontally position the switch at the desired location in the rack, and secure the other end of the rack-mount brackets to front square holes of the rack using four M6 screws and four cage nuts.

Figure 3-2 Installing the Switch in a Rack

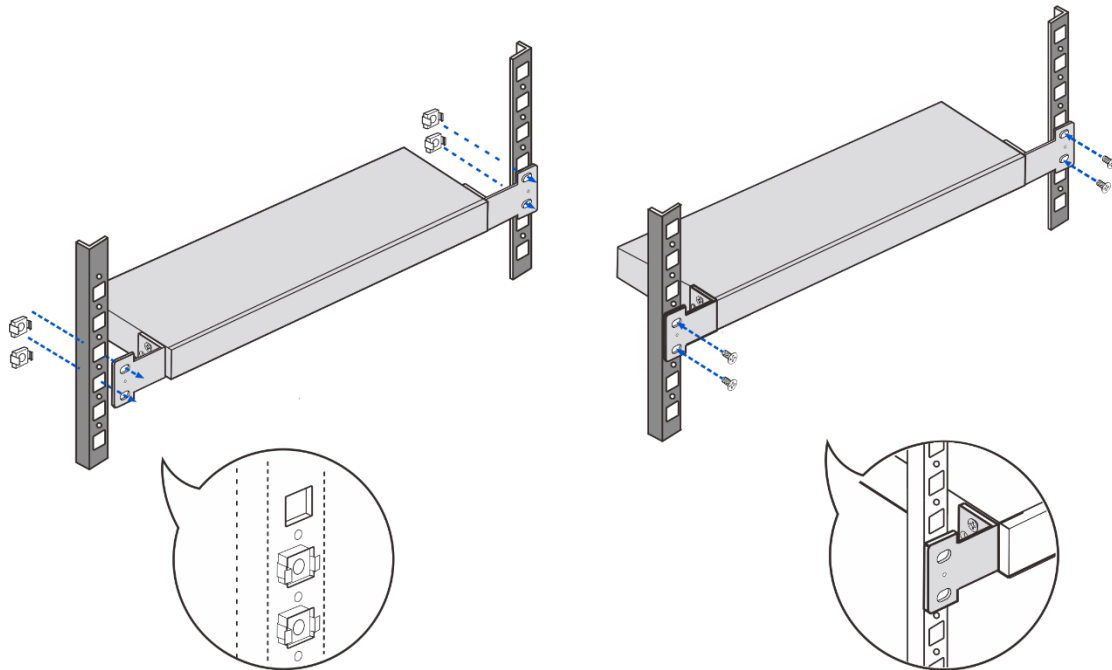

3.2.2 Workbench Mount

In most cases, users do not have a standard rack, and equipment can be placed on a clean workbench. The installation process is as follows:

- (1) Attach the four rubber pads in the package to the dents at the four corners on the bottom of the switch.

Figure 3-3 Attaching the Rubber Pads

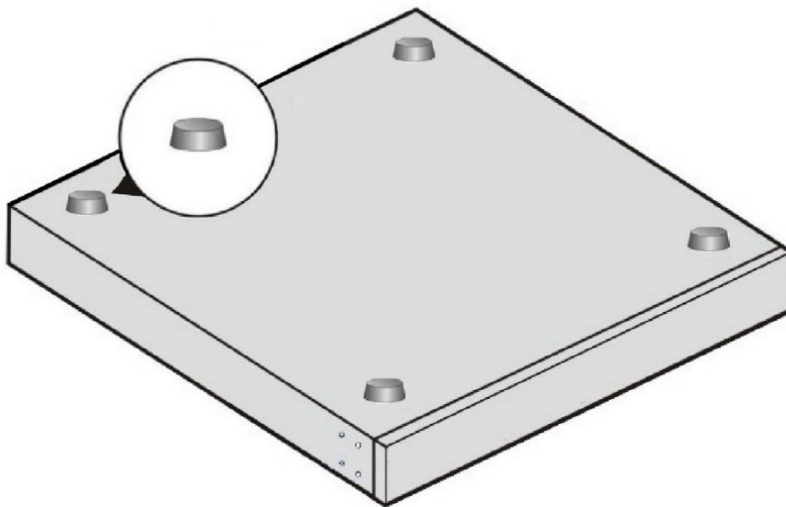

- (2) Place the equipment on a workbench.

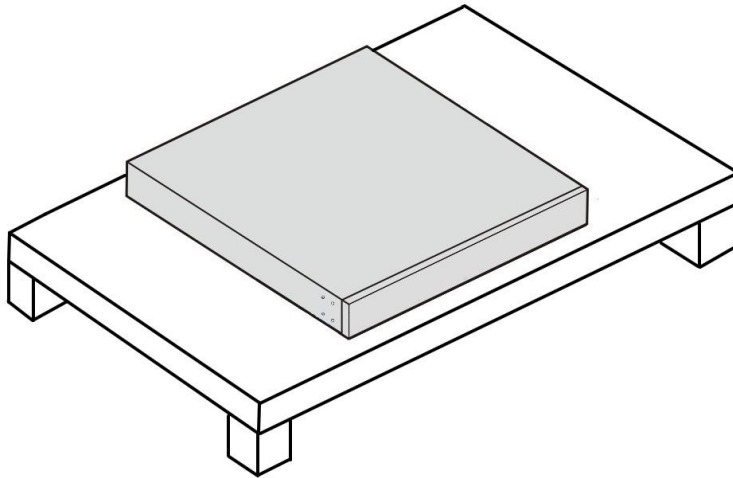
Figure 3-4 Placing the Equipment on a Workbench

3.3 Grounding the Equipment

Note

- If the equipment is installed on a workbench, connect the grounding wire to the nearest grounding bar or grounding point based on the onsite situation.
 - The grounding wire is not delivered with the equipment and needs to be purchased by the customer.
-

The equipment has a grounding stud on the rear panel. You are advised to connect the system grounding wire to it before using the equipment.

- (1) Purchase a grounding wire and connect one end to the grounding stud at the rear of the equipment.
- (2) Connect the other end to the grounding lug of the rack. Ensure the grounding lug of the rack has been connected to the grounding bar.

Caution

- To avoid personal injury and equipment damage, connect the switch to earth ground properly. The grounding resistance between the chassis and the ground should be less than 1 ohm.
 - The O&M personnel should verify whether the AC socket is reliably connected to the protective ground of the building. If not, the O&M personnel should use a protective grounding wire to connect the protective grounding lug of the AC socket to the protective ground of the building.
 - The power socket should be installed near the equipment and easily accessible.
 - During the equipment installation, connect the grounding wire first and disconnect it last.
 - The sectional area of a grounding wire should be determined according to the possible maximum current. Grounding wires with good conductors should be used.
 - Do not use bare wires.
-

3.4 Connecting Cables

Caution

- All cables must be routed indoors. Take surge protection measures if they need to be routed outdoors.
 - When connecting an optical cable, connect the transmit (TX) port on the local equipment to the receive (RX) port on the peer equipment, and vice versa.
-

After the switch is installed, connect the switch to other equipment according to the following steps:

- (1) Connect the power cord delivered with the switch to the power strip.
- (2) Connect the RJ45 connector of a twisted pair to an Ethernet port on the switch, and the other end to downlink equipment.
- (3) Insert an optical transceiver into the optical port first according to the panel identification. Then connect a single-mode fiber (SMF) or multimode fiber (MMF) to the corresponding optical transceiver, during which the transmitting and receiving ends of the optical cable should be distinguished.

3.5 Bundling Cables

3.5.1 Precautions

- Bundle the power cord and other cables in an esthetically pleasing way.
- Make sure that the optical cables at the connectors have natural bends or bends of large radius.
- Do not bind optical cables and twisted pairs too tightly, as this may press the cables and affect their service life and transmission performance.

3.5.2 Bundling Procedure

- (1) Bind the drooping part of the optical cables and twisted pairs, and lead them to both sides of the chassis for convenience.
- (2) On both sides of the chassis, fasten the optical cables and twisted pairs to the cable management ring or cabling chute.
- (3) Bind the power cord closely along the bottom of the chassis, in a straight line wherever possible.

3.6 Verifying Installation

Caution

Please turn off the power to avoid personal injury and damage to components caused by incorrect connection.

- Verify that the grounding wire is connected.
- Verify that the cables including power cords are properly connected.
- Verify that cables connected to ports are routed indoors.
- Verify that the surge protection socket and Ethernet port arrester are installed, if outdoor cabling exists.
- Verify that there is a minimum clearance of 10 cm (3.94 in.) around the switch.

4 Commissioning

4.1 Power-on

- (1) Checklist Before Power-on
 - The switch is properly grounded.
 - The power cord is properly connected.
 - The power supply voltage meets the requirement of the switch.
- (2) Checklist After Power-on (Recommended)
 - The switch LEDs are in the normal state.
 - Service ports can forward data properly.

4.2 Logging In to the Management Interface

- (1) Connect a PC to an Ethernet port on the switch through an Ethernet cable.
- (2) Set the IP address of the PC to 10.44.77.XXX (Range: 1–254, excluding 200).

Figure 4-1 Changing the IP Address

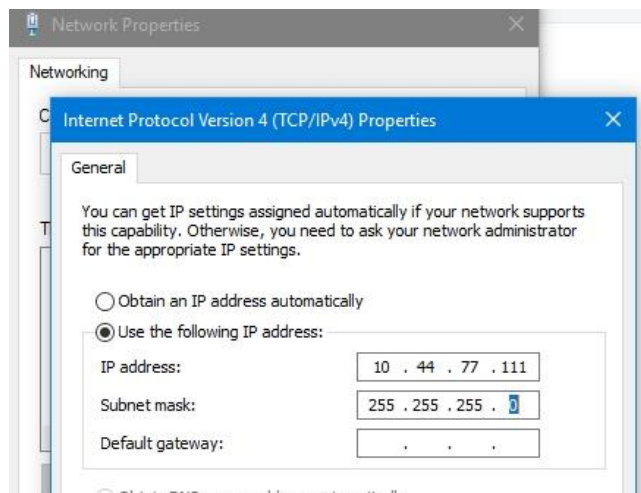

- (3) Open a browser, enter 10.44.77.200 in the address bar, and press Enter. On the login page, set a password and log in.
- (4) Perform equipment commissioning and configuration based on service requirements.

Note

For security purposes, you are advised to change the password regularly.

5 Troubleshooting

5.1 General Troubleshooting Flowchart

Note

You can determine whether each checking item in the process is normal based on the information provided in the previous chapters "Overview" and "Installing the Switch."

Figure 5-1 General Troubleshooting Flowchart

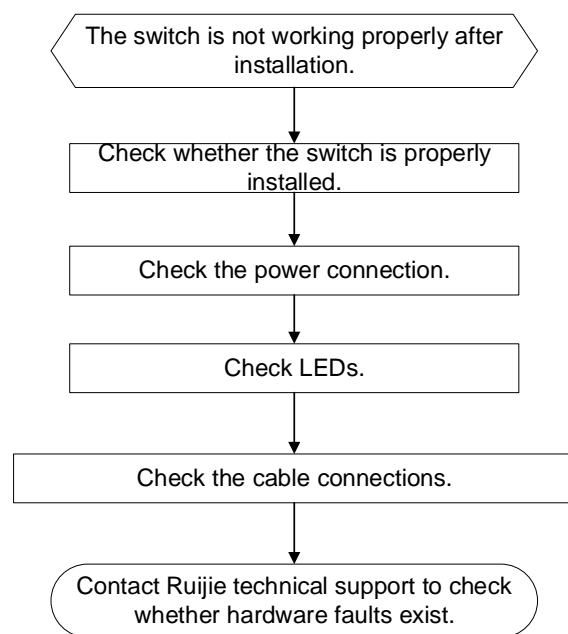

5.2 Common Faults

Table 5-1 Common Faults and Troubleshooting

Symptom	Possible Cause	Suggested Action
The system status LED is off after the switch is powered on.	No power is supplied to the switch or the power cord is loosely connected.	Check whether the power socket in the equipment room is normal and whether the power cord is loosely connected to the switch.
An RJ45 port is disconnected or a frame	The twisted pair is not connected properly.	Replace the twisted pair.

Symptom	Possible Cause	Suggested Action
sending/receiving error occurs.	The cable length exceeds 100 m (328.08 ft.).	Use an optical cable for data transmission or connect to an intermediate switch for relay.
	The port is specially configured and does not work in the same mode as that of the interconnected switch.	Check whether the port is configured to work in the same mode as that of the interconnected switch.
An optical port is not reachable.	The transmit and receive ends are connected incorrectly.	Exchange the transmit and receive ends of the optical cable.
	The types of the interconnected optical transceivers do not match.	Replace with one compatible optical transceiver.
	The optical cable type does not meet the requirements.	Replace the optical cable with a qualified one.
	The optical cable length is beyond the allowed length marked on the optical transceiver.	Use an optical cable with the required length.
	The optical cable or connector is contaminated.	Clean the connector with a lint-free cloth or a cleaning pen.
The login password cannot be retrieved.	The password is forgotten, and the equipment is not connected to the network or Ruijie Cloud.	Press and hold the Reset button to restore to factory settings.
	If the equipment is connected to Ruijie Cloud or a network, its login password is updated to the project or global management password.	If the equipment is connected to the cloud, log in using the project management password. If the equipment is connected to a network, log in using the global management password.

6 Appendix

6.1 Connectors and Media

6.1.1 100r100Or1000BASE-T Port

The 10/100/1000BASE-T port supports auto-negotiation for 10 Mbps, 100 Mbps, and 1000 Mbps connections and also supports auto MDI/MDIX Crossover.

Compliant with IEEE 802.3ab, a 1000BASE-T port connects to a 100-ohm Category 5 (CAT5) or Category 5 Enhanced (CAT5e) Unshielded Twisted Pair (UTP), or recommended Shielded Twisted Pair (STP) cable with a maximum distance of 100 m (328.08 ft.).

The 1000BASE-T port requires that all four pairs of wires be connected for data transmission. [Figure 6-1](#) shows twisted pair connections for the 1000BASE-T port.

Figure 6-1 Twisted Pair Connections for a 1000BASE-T Port

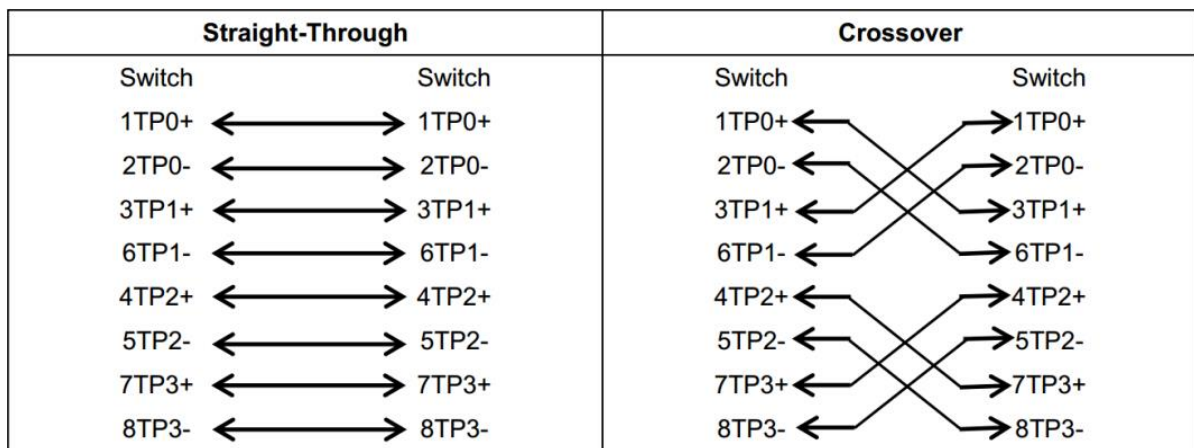

In addition to cables with the above-mentioned specifications, the 10/100BASE-T port can also be connected using 100-ohm CAT3, CAT4, and CAT5 cables at 10 Mbps or using 100-ohm CAT5 cables with a maximum distance of 100 m (328.08 ft.). The following table shows pin assignments for a 10/100BASE-T port.

Table 6-1 10/100BASE-T Pin Assignment

Pin	Socket	Plug
1	Input Receive Data+	Output Transmit Data+
2	Input Receive Data-	Output Transmit Data-
3	Output Transmit Data+	Input Receive Data+
6	Output Transmit Data-	Input Receive Data-
4, 5, 7, and 8	Not Used	Not Used

The following table shows wiring of straight-through and crossover cables for a 10/100BASE-T port.

Figure 6-2 Twisted Pair Connections for a 10/100BASE-T Port

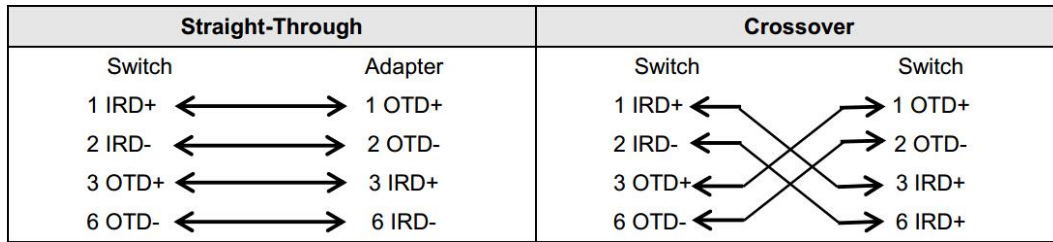

6.1.2 Optical Cable Connection

Select a single-mode fiber (SMF) or multimode fiber (MMF) for connections based on the type of the optical transceiver inserted into an optical port. [Figure 6-3](#) shows the connections.

Figure 6-3 Connecting the Optical Cables

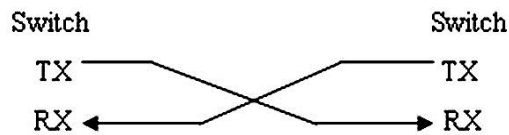

6.2 SFP Transceivers

Ruijie provides SFP transceivers (mini-GBIC) based on the port types. You can select one that suits your specific needs. In addition to the following 1GE SFP transceivers, the 1GE copper transceiver Mini-GBIC-GT is also supported. This document provides models and technical specifications of some 1GE SFP transceivers for reference. For details about the technical specifications, see *Ruijie Transceiver Installation and Reference Guide*.

Table 6-2 1GE Mini-GBIC (SFP) Models and Technical Specifications

Model	Wavelength (nm)	Fiber Type	DDM Supported (Yes/No)	Transmit Power (dBm)		Receive Power (dBm)	
				Min	Max	Min	Max
MINI-GBIC-SX-MM850	850	MMF	Yes	-9	-3	-20	-3
MINI-GBIC-LX-SM1310	1310	SMF	Yes	-9	-3	-26	0
GE-SFP-LH40-SM1310-BIDI	1310TX/1550RX	SMF	Yes	-3	3	-25	0
GE-SFP-LH40-SM1550-BIDI	1550TX/1310RX	SMF	Yes	-3	3	-25	0

GE-SFP-LX20-SM1310-BIDI	1310TX/1550RX	SMF	Yes	-8	-3	-23	-3
GE-SFP-LX20-SM1550-BIDI	1550TX/1310RX	SMF	Yes	-8	-3	-23	-3
MINI-GBIC-LH40-SM1310	1310	SMF	Yes	-5	0	-25	-3
MINI-GBIC-ZX80-SM1550	1550	SMF	Yes	-3	3	-26	-3
GE-SFP-LX03-SM1310-BIDI-I	1310TX/1550RX	SMF	Yes	-9	-3	-22	-3
GE-SFP-LX03-SM1550-BIDI-I	1550TX/1310RX	SMF	Yes	-9	-3	-22	-3
SFP-MM850	850	MMF	Yes	-9.5	-3	-17	-3
SFP-SM1310	1310	SMF	Yes	-9	-3	-20	-3

Table 6-3 1GE SFP Copper Transceivers

Standard	1000BASE-T SFP Module	DDM Supported (Yes/No)
1000BASE-T	Mini-GBIC-GT	No

Table 6-4 2.5GE Mini-GBIC (SFP) Models and Technical Specifications

Model	Wavelength (nm)	Fiber Type	Trusted Platform Module (DDM) (Yes/No)	Transmit Power (dBm)		Receive Power (dBm)	
				Min	Max	Min	Max
2.5G-SFP-LX03-SM1310-BIDI-I	1310TX/1550RX	SMF	YES	-9	-3	-16	0
2.5G-SFP-LX03-SM1550-BIDI-I	1550TX/1310RX	SMF	YES	-9	-3	-16	0

Table 6-5 Cabling Specifications of SFP Transceivers

SFP Transceiver Model	Port Type	Fiber Type	Core Size (µm)	Max Cabling Distance
SFP-SM1310	LC	SMF	9/125	10 km (6.21 miles)

SFP Transceiver Model	Port Type	Fiber Type	Core Size (µm)	Max Cabling Distance
MINI-GBIC-LX-SM1310	LC	SMF	9/125	10 km (6.21 miles)
GE-SFP-LH40-SM1310-BIDI	LC	SMF	9/125	40 km (24.85 miles)
GE-SFP-LH40-SM1550-BIDI	LC	SMF	9/125	40 km (24.85 miles)
GE-SFP-LX20-SM1310-BIDI	LC	SMF	9/125	20 km (12.43 miles)
GE-SFP-LX20-SM1550-BIDI	LC	SMF	9/125	20 km (12.43 miles)
MINI-GBIC-LH40-SM1310	LC	SMF	9/125	40 km (24.85 miles)
MINI-GBIC-ZX80-SM1550	LC	SMF	9/125	80 km (49.71 miles)
GE-SFP-LX03-SM1310-BIDI-I	LC	SMF	9/125	3 km (1.86 miles)
GE-SFP-LX03-SM1550-BIDI-I	LC	SMF	9/125	3 km (1.86 miles)
MINI-GBIC-SX-MM850	LC	MMF	62.5/125	275 m (902.23 ft.)
			50/125	550 m (1,804.46 ft.)
SFP-MM850	LC	MMF	62.5/125	275 m (902.23 ft.)
			50/125	550 m (1,804.46 ft.)
2.5G-SFP-LX03-SM1310-BIDI-I	LC	MMF	9/125	3 km (1.86 miles)
2.5G-SFP-LX03-SM1550-BIDI-I	LC	MMF	9/125	3 km (1.86 miles)
Mini-GBIC-GT	RJ45 Ethernet cable	CAT5 or better UTP or STP cable		100 m (328.08 ft.)

⚠ Caution

- For optical transceivers with a cabling distance of no less than 40 km (24.85 miles), install an optical attenuator to avoid overload on an optical receiver when using short-distance SMFs.
- An optical transceiver is a laser transmitter. Do not look into the light source to prevent it from burning your eyes.
- To keep the optical transceiver clean, make sure that the unused ports remain capped.

Table 6-6 BIDI Optical Transceiver Pairing

Rate/Distance	Pairing Model
1000 Mbps/3 km (1.86 miles)	<ul style="list-style-type: none"> ● GE-SFP-LX03-SM1310-BIDI-I ● GE-SFP-LX03-SM1550-BIDI-I

1000 Mbps/20 km (12.43 miles)	<ul style="list-style-type: none"> ● GE-SFP-LX20-SM1310-BIDI ● GE-SFP-LX20-SM1550-BIDI
1000 Mbps/40 km (24.85 miles)	<ul style="list-style-type: none"> ● GE-SFP-LH40-SM1310-BIDI ● GE-SFP-LH40-SM1550-BIDI

⚠ Caution

BIDI optical transceivers must be used in pairs. For example, if GE-SFP-LX20-SM1310-BIDI is used at one end, GE-SFP-LX20-SM1550-BIDI must be used at the other end.

6.3 Lightning Protection

6.3.1 Installing the AC Power Arrester (Power Strip with Surge Protection)

When an alternating current (AC) power cord is introduced from outdoors and directly connected to the AC power port of the switch, the power port must be connected to an external power arrester to safeguard the switch against lightning strikes. The power arrester can be fixed on the rack, workbench, or wall in the equipment room by using cable ties and screws. AC power enters the power arrester before entering the switch.

Figure 6-4 Power Arrester

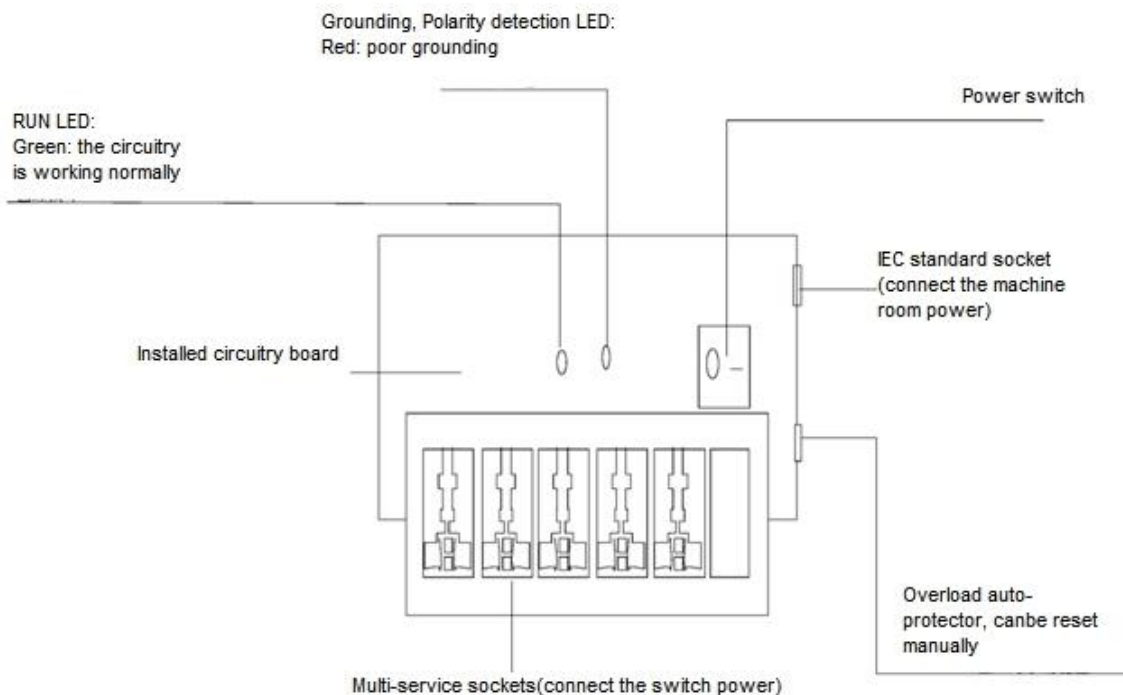

⚠ Caution

The power arrester is not delivered with the equipment. Please purchase it based on actual requirements.

Precautions during the installation:

- Make sure that the PE terminal of the power arrester is well grounded.
- After the AC power plug of the switch is connected to the socket of the power arrester, the lightning protection function is implemented only if the running status LED is green and the alarm LED is off.
- If the alarm LED on the power arrester is red, check whether it is caused by a poor grounding connection or by the reversed connection of the neutral and live wires. The detection method is as follows: Use a multimeter to measure the polarity of the power arrester when the alarm LED is red. If the neutral wire is on the left and the live wire is on the right (facing the socket), the PE terminal of the power arrester is not grounded. If not, the polarity of the power arrester should be reversed. In this case, open the power arrester and reverse its polarity. If the alarm LED is still red, the PE terminal of the power arrester is not grounded.

6.3.2 Installing the Ethernet Port Arrester

Please connect an Ethernet port arrester to the switch to prevent the damage by lightning strikes before connecting an outdoor Ethernet cable to the switch.

- Tools: Phillips screwdriver or flat-blade screwdriver, multimeter, and diagonal pliers
- Installation steps
 - a Tear one side of the protective paper for the double-sided adhesive tape and paste the tape to the enclosure of the Ethernet port arrester. Tear the other side of the protective paper for the double-sided adhesive tape and paste the Ethernet port arrester to the switch enclosure. The paste position for the Ethernet port arrester should be as close to the grounding lug of the switch as possible.
 - b Based on the distance between the grounding lug of the switch and the Ethernet port arrester, cut the grounding cable of the Ethernet port arrester and firmly tighten the grounding cable to the grounding lug of the switch.
 - c Use a multimeter to check whether the grounding cable for the arrester is in good contact with the grounding lug and the enclosure of the switch.
 - d Connect the Ethernet port arrester by using an adapter cable (note that the external Ethernet cable is connected to the IN end, while the adapter cable connected to the switch is connected to the OUT end) and check whether the module LED is normal.
 - e Use a nylon cable tie to bind the cables.

Figure 6-5 Installing an Ethernet Port Arrester

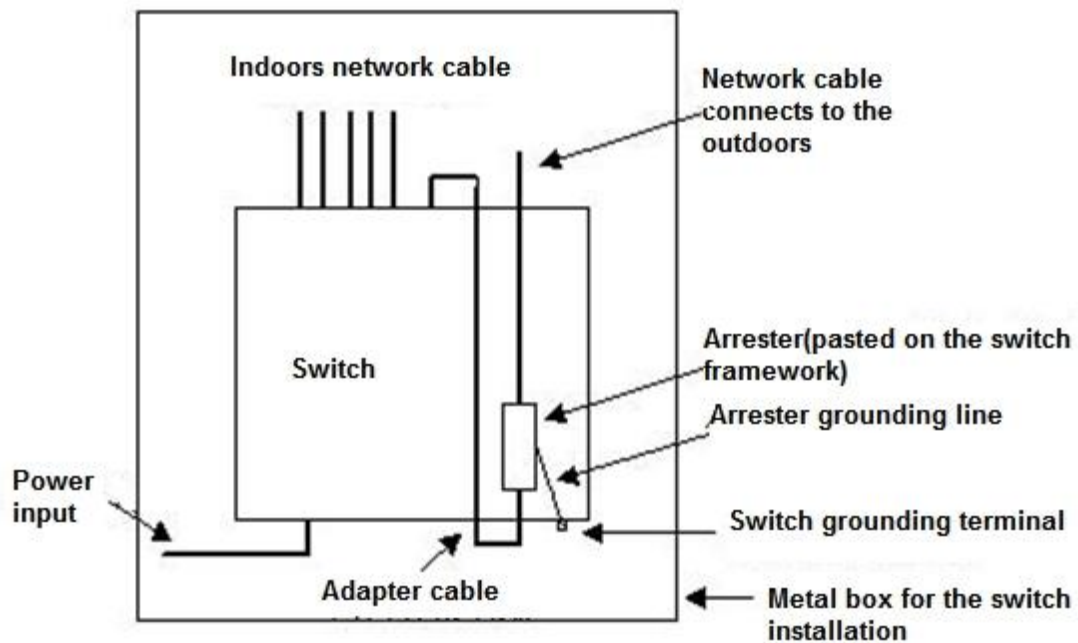

⚠ Caution

- The Ethernet port arrester is only for a 10 Mbps, 100 Mbps, or 1000 Mbps RJ45 port.
- The Ethernet port arrester is not delivered with the equipment. Please purchase it based on actual requirements. The user manual for Ethernet port arresters contains technical parameters and maintenance and installation instructions. Carefully read this manual during installation.

Pay attention to the following situations during the actual installation to avoid influencing the performance of an Ethernet port arrester:

- The arrester is incorrectly connected to the cables. Connect the external Ethernet cable to the IN end and connect the Ethernet port of the switch to the OUT end.
- The Ethernet port arrester is incorrectly grounded. The grounding cable of the arrester should be as short as possible to ensure that it is in good contact with the grounding lug of the switch. Use a multimeter to confirm the contact condition after grounding.
- Not all Ethernet ports are installed with Ethernet port arresters. If outdoor Ethernet cables connect the switch ports to the peer equipment, Ethernet port arresters need to be installed on all the ports for the purpose of lightning protection.

6.4 Recommended Cabling

When the switch is installed in a standard 19-inch cabinet, secure the cables around the cable management brackets. Top cabling or bottom cabling is adopted according to the actual situation in the equipment room. All adapted connectors should be placed at the bottom of the rack in an orderly manner instead of outside the rack that is easy to touch. Power cords are routed beside the rack. Top cabling or bottom cabling is adopted according

to the actual situation in the equipment room, such as the positions of the DC power distribution box, AC socket, or lightning protection box.

6.4.1 Requirement for the Minimum Bend Radius of Cables

- The bend radius of a fixed power cord, Ethernet cable, and flat cable should be over five times greater than their respective external diameters. The bend radius of these cables that are often bent or plugged should be over seven times greater than their respective external diameters.
- The bend radius of a fixed common coaxial cable should be over seven times greater than its external diameter. The bend radius of these cables that are often bent or plugged should be over 10 times greater than their respective external diameters.
- The minimum bend radius of a high-speed cable, such as an SFP+ cable, should be 5 times the overall diameter of the cable. If the cable is constantly bent, plugged or unplugged, the bend radius should be 10 times the overall diameter.
- The minimum bend radius of optical cables should meet the following requirements.
 - The diameter of the optical cable tray should be no less than 25 times greater than that of the optical cable.
 - When an optical cable is moved, its bend radius should be no less than 20 times greater than its diameter.
 - During cabling of an optical cable, its bend radius should be no less than 10 times greater than its diameter.

6.4.2 Precautions for Cable Bundling

- Before cables are bundled, mark labels and stick the labels to cables wherever appropriate.
- Cables should be neatly and properly bundled in the rack without twisting or bending, as shown in [Figure 6-6](#).

Figure 6-6 Bundling Cables (1)

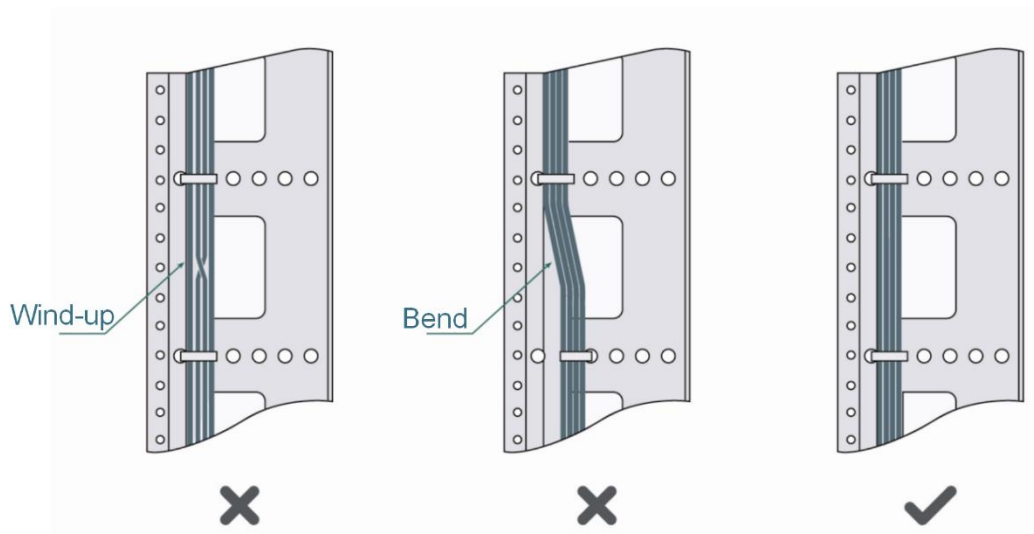

- Cables of different types (such as power cords, signal cables, and grounding wires) should be separated in cabling and bundling. Mixed bundling is not allowed. When they are close to each other, you are advised to

adopt crossover cabling. In the case of parallel cabling, maintain a minimum distance of 30 mm (1.18 in.) between power cords and signal cables.

- The cable management brackets and cabling troughs inside and outside the rack should be smooth without sharp corners.
- The metal holes traversed by cables should have a smooth and fully rounded surface or an insulated lining.
- Use cable ties to bundle cables properly. Please do not connect two or more cable ties to bundle cables.
- After bundling up cables with cable ties, cut off the remaining part. The cut should be smooth and trim without sharp corners, as shown in [Figure 6-7](#).

Figure 6-7 Bundling Cables (2)

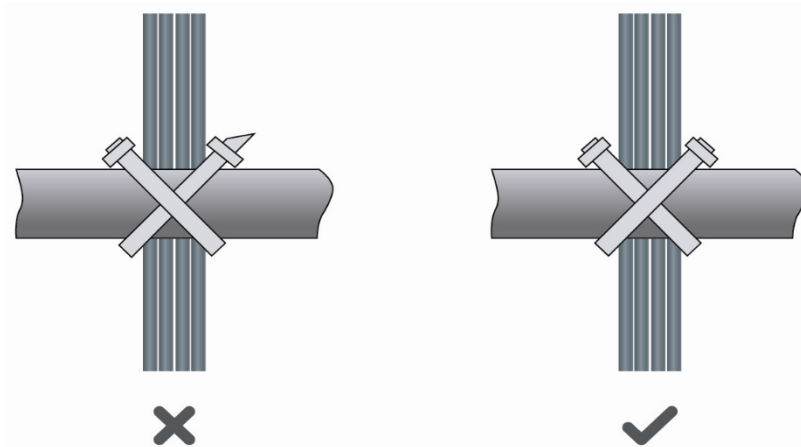

- When cables need to be bent, bundle them first but do not tie cables within the bend. Otherwise, stress may be generated on the cables and cause the wires inside to break, as shown in [Figure 6-8](#).

Figure 6-8 Bundling Cables (3)

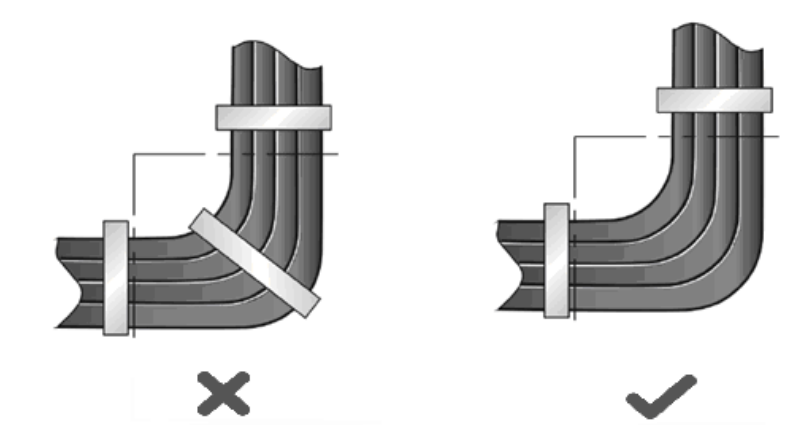

- Cables not to be assembled or the remaining parts of cables should be folded and placed in a proper position of the rack or cable management trough. The proper position refers to a position that does not affect the equipment running or damage the equipment or cables.
- Power cords must not be bundled on the guide rails of moving parts.
- The power cords connecting moving parts such as door grounding wires should be reserved with some

excess after being assembled to avoid suffering tension or stress. When a moving part reaches the installation position, the remaining cable part should not touch heat sources, sharp corners, or sharp edges. If heat sources must be touched, high-temperature cables should be used.

- When using screw threads to secure a cable lug, ensure that the bolt or screw is properly tightened and take measures to prevent it from loosening, as shown in [Figure 6-9](#).

Figure 6-9 Fastening Cables

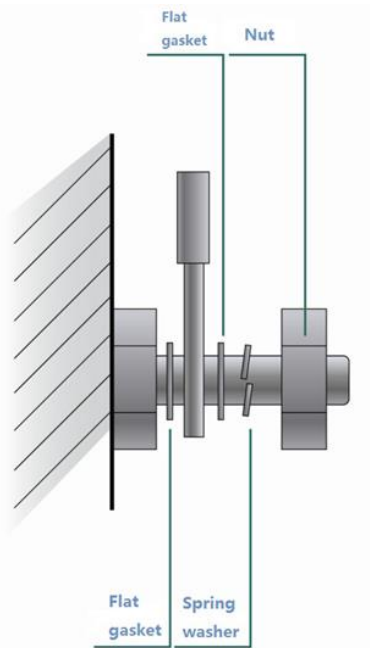

- Hard power cords should be secured near the cable termination area to prevent stress on the cable termination area and cables.
- Do not use tapping screws to secure cable lugs.
- Power cords of the same type and in the same cabling direction should be bundled up into cable bunches, with cables in cable bunches clean and straight.
- Bundle cables by using cable ties according to the following table.

Cable Bunch Diameter	Bundling Spacing
10 mm (0.39 in.)	80–150 mm (3.15–5.91 in.)
10–30 mm (0.39–1.18 in.)	150–200 mm (5.91–7.87 in.)
30 mm (1.18 in.)	200–300 mm (7.87–11.81 in.)

- Do not tie cables or bundles in a knot.
- For wiring terminal blocks (such as circuit breakers) with cord end terminals, the metal part of the cord end terminal should not be exposed outside the terminal block when assembled.

6.5 Site Selection

- The equipment room should be at least 5 km (3.11 miles) away from heavy pollution sources, such as smelters, coal mines, and thermal power plants. The equipment room should be at least 3.7 km (2.30 miles) away from medium pollution sources, such as the chemical factory, rubber factory, and electroplating factory. The equipment room should be at least 2 km (1.24 miles) away from light pollution sources, such as the food factory and leather plant. If the pollution source is unavoidable, the equipment room should be located on the windward side of the pollution source perennially with advanced protection.
- The equipment room should be at least 3.7 km (2.30 miles) away from the sea or salt lake. Otherwise, the equipment room must be sealed, with an air conditioner installed for temperature control. Saline soil cannot be used for construction. Otherwise, you should select equipment with advanced protection against severe environments.
- Do not build the equipment room in the proximity of livestock farms. Otherwise, the equipment room should be located on the windward side of the pollution source perennially. The previous livestock house or fertilizer warehouse cannot be used as the equipment room.
- The equipment room should be firm enough to withstand severe weather conditions such as windstorms, heavy rain, and dense dust. If the dust is unavoidable, keep the door and window away from the pollution source.
- The equipment falls into Class A. Therefore, the equipment room should be located away from the residential area. Otherwise, the equipment room should meet construction specifications to avoid noise and radio interference.
- Make sure the air vent of the equipment room is away from the sewage pipe, septic tank, and sewage treatment tank. Keep the equipment room under positive pressure to prevent corrosive gas from entering the equipment room to corrode components and circuit boards.
- Keep the equipment room away from industrial boilers and heating boilers.
- The equipment room should be on the second floor or higher. Otherwise, the equipment room floor should be 600 mm (23.62 in.) higher than the highest flood level ever recorded.
- Make sure no cracks or holes exist in the wall and floor. If there are cable entries in the wall or window, take proper sealing measures. Ensure that the wall is flat, wear-resistant, and dust-free, meeting standards for flame resistance, soundproofing, heat absorption, dust reduction, and electromagnetic shielding.
- Keep the door and the window closed to make the equipment room sealed.
- You are advised to use the steel door for soundproofing.
- Do not use sulfur-containing materials.
- Keep the air conditioner from blowing wind straight toward the equipment or blowing water drops from the window or air vent toward the equipment.

Contents

1 Overview	4
1.1 About the RG-ES228GS-P-V2	4
1.2 Equipment Appearance	4
1.2.1 Front Panel.....	4
1.2.2 Rear Panel	5
1.2.3 LEDs	6
1.3 Cooling.....	6
1.4 Technical Specifications	7
2 Preparing for Installation	9
2.1 Package Contents.....	9
2.2 Safety Guidelines.....	9
2.2.1 General Precautions	9
2.2.2 Chassis-Lifting Guidelines	10
2.2.3 Electricity Safety	10
2.2.4 Preventing ESD Damage.....	11
2.2.5 Laser Safety	11
2.3 Site Requirements	12
2.3.1 Floor Loading	12
2.3.2 Airflow.....	12
2.3.3 Space	12
2.3.4 Temperature and Humidity.....	12
2.3.5 Cleanliness.....	12

2.3.6 Grounding	13
2.3.7 Preventing Electromagnetic Interference	14
2.3.8 Surge Protection	14
2.3.9 Installation Site.....	14
2.4 Rack Requirements	14
2.5 Tools	15
3 Installing the Switch	16
3.1 Before You Begin.....	16
3.2 Installing the Switch	16
3.2.1 Rack Mount.....	16
3.2.2 Workbench Mount.....	17
3.3 Grounding the Equipment.....	18
3.4 Connecting Cables.....	19
3.5 Bundling Cables.....	19
3.5.1 Precautions	19
3.5.2 Bundling Procedure	19
3.6 Verifying Installation.....	19
4 Commissioning.....	21
4.1 Power-on.....	21
4.2 Logging In to the Management Interface.....	21
5 Troubleshooting.....	22
5.1 General Troubleshooting Flowchart	22
5.2 Common Faults.....	22
6 Appendix.....	24

6.1 Connectors and Media.....	24
6.1.1 10Or100Or1000BASE-T Port	24
6.1.2 Optical Cable Connection	25
6.2 SFP Transceivers	25
6.3 Lightning Protection	28
6.3.1 Installing the AC Power Arrester (Power Strip with Surge Protection)	28
6.3.2 Installing the Ethernet Port Arrester	29
6.4 Recommended Cabling	30
6.4.1 Requirement for the Minimum Bend Radius of Cables	31
6.4.2 Precautions for Cable Bundling	31
6.5 Site Selection	34

1 Overview

1.1 About the RG-ES228GS-P-V2

The RG-ES228GS-P-V2 Ethernet switch provides 26 10/100/1000BASE-T ports, two 1GE SFP ports, one Reset button, one DIP switch, and several LEDs on the front panel, along with an AC power port and a grounding stud on the rear panel. Ports 1–24 support Power over Ethernet (PoE) Out.

Figure 1-1 RG-ES228GS-P-V2 Appearance



Note

- 1GE SFP port: Supports only 1GE SFP optical transceivers (not compatible with 100 Mbps optical cables).
- 10/100/1000BASE-T port: Supports auto-negotiation at 10 Mbps, 100 Mbps, and 1000 Mbps.

1.2 Equipment Appearance

1.2.1 Front Panel

Figure 1-2 Front Panel of the RG-ES228GS-P-V2

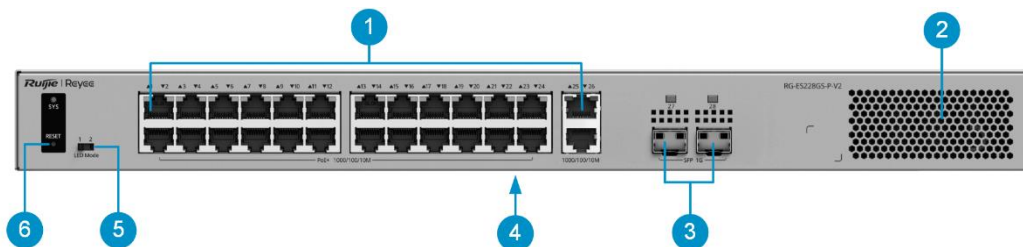

Table 1-1 Components on the Front Panel

No.	Component	Silkscreen	Description
1	RJ45 port	1000/100/10M	10/100/1000BASE-T ports, with ports 1–24 supporting PoE Out.

No.	Component	Silkscreen	Description
2	Ventilation openings	-	Used for heat dissipation of the switch.
3	SFP port	SFP 1G	1GE SFP port, supporting 1GE SFP transceiver (hot-swappable)
4	Nameplate	-	It is located at the bottom of the switch.
5	DIP switch	LED Mode	Toggle the DIP switch to change the LED modes of ports 1–24. <ul style="list-style-type: none"> LED mode 1 (switching mode): When the DIP switch is toggled to the left, the port LEDs display the data transmission status. LED mode 2 (PoE mode): When the switch is toggled to the right, the port LEDs display the PoE status.
6	Reset button	RESET	<ul style="list-style-type: none"> Press and hold the button for less than 2 seconds. The switch is reset. Press and hold the button for 2–5 seconds. No action is performed. Press and hold the button for more than 5 seconds, and release the button until the system status LED starts blinking to restore factory settings and restart the switch.

Note

For details about LEDs on the front panel, see "LEDs."

1.2.2 Rear Panel

Figure 1-3 Rear Panel of the RG-ES228GS-P-V2

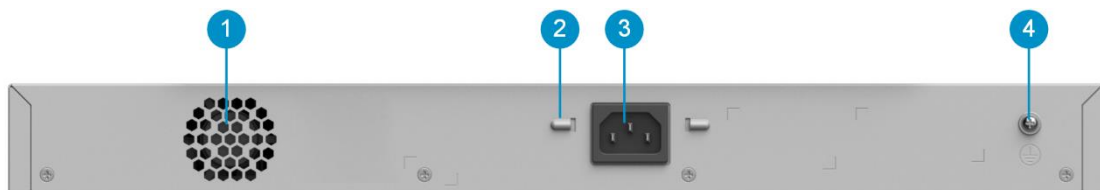

Table 1-2 Components on the Rear Panel

No.	Component	Description
1	Fan opening	Ensures smooth airflow into and out of the fan, and to facilitate heat dissipation of the equipment.
2	Power cable spring clip hole	Secures the power cord retention clip to the holes.
3	Power port	Indicates a three-pin power port used for AC power connection.
4	Grounding stud	Used to connect the switch to the ground.

1.2.3 LEDs

Figure 1-4 RG-ES228GS-P-V2 LEDs

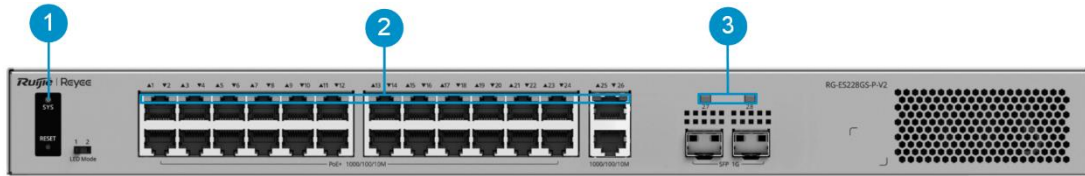

Table 1-3 LEDs

No.	Component	Silkscreen	Description
1	System status LED	SYS	<ul style="list-style-type: none"> ● Off: The switch is not powered on. ● Slow blinking green (0.5 Hz): The switch is operating normally but is not connected to Ruijie Cloud. ● Fast blinking green (10 Hz): The switch is upgrading or restarting, and is temporarily unavailable. ● Solid green: The switch is operating normally and connected to Ruijie Cloud. ● Slow blinking yellow (0.5 Hz): The PoE power is insufficient. ● Slow blinking red (0.5 Hz): A loop occurs on the switch with loop guard enabled.
2	RJ45 port LED	1–26	<p>LEDs of ports 1–24 support switching mode and PoE mode, which can be switched by toggling the DIP switch on the front of the switch. LEDs of ports 25 and 26 support only switching mode.</p> <ul style="list-style-type: none"> ● Switching mode: <ul style="list-style-type: none"> ○ Off: The port is not connected. ○ Solid green: The port is operating at 1000 Mbps, 100 Mbps, or 10 Mbps, but is not receiving or sending data. ○ Blinking green: The port is operating at 1000 Mbps, 100 Mbps, or 10 Mbps, and is receiving or sending data. ● PoE mode: <ul style="list-style-type: none"> ○ Off: PoE is disabled on the port. ○ Solid green: PoE is enabled on the port. ○ Blinking green: PoE overload occurs on the port.
3	SFP port LED	27, 28	<ul style="list-style-type: none"> ● Off: The port is not connected. ● Solid green: The port is operating at 1000 Mbps, but is not receiving or sending data. ● Blinking green: The port is operating at 1000 Mbps, and is receiving or sending data.

1.3 Cooling

The RG-ES228GS-P-V2 switch has one fixed fan, which adopts air cooling. Air flows in from the left, right, and front sides and out from the rear side. To ensure that the equipment works properly in the specified environment,

a minimum clearance of 10 cm (3.94 in.) must be maintained around the equipment for air circulation and ventilation. Dust the equipment every three months to avoid obstructing the air-exhaust grid of the chassis.

1.4 Technical Specifications

Warning

- This equipment is not suitable for use in locations where children are likely to be present.
- Operation of this equipment in a residential environment could cause radio interference.

Table 1-4 Technical Specifications

Parameter Type	Parameter Name	RG-ES228GS-P-V2
System Specifications	Forwarding rate	41.664 Mpps
	Switching capacity	56 Gbps(bit/s)
	Flash memory	8 MB
Port Specifications	Total number of optical ports	2
	Total number of RJ45 ports	26
	Number of 10/100/1000BASE-T ports	26
	Number of 1GE SFP ports	2
	Reset button	1
	LEDs	1 x system status LED 26 x Ethernet port LEDs 2 x SFP port LEDs
	DIP switch	LED mode switch toggled to left (Mode 1): The port LED status indicates the status of traffic transmission. Solid green means that the port is link up, while blinking green means that the port is transmitting and receiving data. LED mode switch toggled to right (Mode 2): The port LED status indicates the PoE status. Solid green means that the port is supplying power, while blinking green means that the port is in power overload state.
Power Supply and Consumption	Power supply	Fixed power supply
	Power input	220 V AC power supply: <ul style="list-style-type: none"> ● Rated input voltage: 100 V AC to 240 V AC, 50 Hz to 60 Hz ● Maximum input voltage: 90 V AC to 264 V AC, 47 Hz to 63 Hz ● Rated input current: 6 A
	Maximum power consumption	25W (with no PoE load) 426W (with full PoE load)
	Number of PoE Out ports	24
	Number of PoE/PoE+ Out ports	24

Parameter Type	Parameter Name	RG-ES228GS-P-V2
	PoE Out standard	PoE/PoE+ (IEEE 802.3af/at)
	PoE power pins	1–2 (+), 3–6 (-)
	PoE budget per port	30 W
	PoE budget	370 W
Dimensions and Weight	Product dimensions (W x D x H)	440mm x 215mm x 44mm (17.32 in. x 8.46 in. x 1.73 in)
	Weight	2.82Kg (6.22 lbs) (without packaging materials)
	Shipping weight	3.77Kg (8.31 lbs)
	Casing	Metal
Interface	EEE	Yes
Environment and Reliability	Mounting options	Rack/Desk
	Hot swapping of cables	Hot swapping supported by the service port and power connector
	Fan	1 x fixed fan
	Cooling	Air cooling, front-to-rear airflow + left-to-rear airflow
	MTBF	200,000 hours
	ESD protection	Air discharge: 8 kV Contact discharge: 6 kV
	Surge protection	Service port: ±6 kV for common mode Power connector: ±6 kV for common mode and ±6 kV for differential mode
	Operating temperature	0°C to 40°C (32°F to 104°F)
	Storage temperature	-40°C to +70°C (-40°F to +158°F)
	Operating humidity	10% RH to 90% RH (non-condensing)
	Storage humidity	5% RH to 95% RH (non-condensing)
	Altitude	-500 m to +5,000 m (-1,640.42 ft. to +16,404.20 ft.)
Certification and Regulatory Compliance	EMC	EN 55032 EN 61000-3-2 EN 61000-3-3 EN 55035 EN 300 386
	Safety compliance	EN 62368-1 IEC 62368-1
	Certification	CE,CB

2 Preparing for Installation

2.1 Package Contents

Table 2-1 Package Contents

No.	Item	Quantity
1	RG-ES228GS-P-V2 switch	1
2	Rubber pad	4
3	<i>User Manual</i>	1
4	<i>Warranty Card</i>	1
5	M4 x 8 mm cross recessed countersunk head screw	6
6	Rack-mount bracket	2
7	Power cord	1
8	Power cord retention clip	1

Note

The package contents are subject to the purchase contract, and actual delivery may vary. Please check the items carefully against the package contents or purchase contract. If you have any questions, please contact the distributor.

2.2 Safety Guidelines

Note

- To avoid personal injury or equipment damage, review the safety guidelines in this chapter before you begin the installation.
 - The following safety guidelines may not include all the potentially hazardous situations.
-

2.2.1 General Precautions

- Install the equipment in a standard 19-inch rack and ensure that the rack and power distribution system are properly grounded.
- Never operate the equipment in a wet environment, and avoid any liquids inside it. Keep the chassis clean and dust-free.
- Keep the equipment away from heat sources.
- Keep the equipment away from walk areas.
- During installation and maintenance, do not wear loose clothing or ornament that may get caught in the

chassis.

- Keep tools and accessories away from walk areas.

2.2.2 Chassis-Lifting Guidelines

- Avoid moving the equipment frequently.
- Turn off all power supplies and disconnect all cables before lifting or moving the equipment.
- Two or more people are required to lift the chassis. Keep balance and prevent personal injuries when lifting or moving the equipment.

2.2.3 Electricity Safety

Warning

- Any deviation from standard or improper electrical operations can result in accidents such as fires or electric shocks, potentially causing severe or even fatal harm to both individuals and equipment.
 - Direct or indirect touch through a wet object on high-voltage and mains supply can bring a fatal danger.
-
- Always observe the local regulations and standards. Only qualified personnel should be allowed to operate the equipment.
 - Carefully check the work area for potential hazards, including ungrounded power system, absent safety grounds, and damp floors.
 - Locate the emergency power-off switch in the room before installation. In the case of an accident, cut off the power supply immediately.
 - Never assume that power is connected to or disconnected from a circuit. Always check.
 - Select the right leakage protector (also called "leakage current switch" or "leakage current breaker") for the power supply system. This equipment automatically disconnects the power supply in the event of leakage and the risk of electric shock. A leakage protector should meet the following requirements:
 - The rated leakage action current of each leakage protector must be at least twice the total maximum leakage current of all connected power supplies.
Example:
If a system has 16 identical power supplies, each with a maximum leakage current of 3.5 mA:
Total leakage current = 16 x 3.5 mA = 56 mA
For a 30 mA leakage protector:
Maximum number of power supplies per protector = 30 mA/2/3.5 mA ≈ 4
Therefore, only four power supplies can be connected to one 30 mA leakage protector.
To support 16 power supplies, at least four 30 mA leakage protectors are required.
Always ensure:
Rated leakage operating current/2 > Total maximum leakage current of connected power supplies
 - The rated leakage non-action current of a leakage protector should be 50% of the leakage action current. If the non-action current value is too small, the high sensitivity level can cause the circuit to break, leading to power cutoff and service interruption, even if the leakage current value is normal.

For example, if a leakage protector has a rated leakage action current of 30 mA, the rated leakage non-action current should be 15 mA. The leakage protector will not activate unless the leakage current exceeds 15 mA.

⚠ Caution

- To ensure personal safety, each leakage protector in the system must have a rated leakage action current equal to or below 30 mA, which is the recognized safety threshold for human body current. If the total leakage current of the system exceeds twice the 30 mA limit, the system must be equipped with two or more leakage protectors to maintain safety.
 - The leakage current values vary with equipment. For the leakage current value of each equipment model, see "Technical Specifications."
-

2.2.4 Preventing ESD Damage

- Ensure that the chassis is connected to earth ground.
- Keep the site as dust free as possible.
- Maintain appropriate humidity conditions.
- Before installing any pluggable modules, wear an anti-ESD wrist strap and make sure that it is properly grounded.
- Avoid contact between the printed circuit boards and clothing. The anti-ESD wrist strap only protects the printed circuit boards from ESD voltages on the body. ESD voltages on clothing can still cause damage.

2.2.5 Laser Safety

The equipment supports various types of optical transceivers, which are Class 1 laser products.

Precautions:

- When an optical transceiver is working, ensure that its port is connected to an optical cable or covered by a dust cap to keep out dust and prevent it from burning your eyes.
- Do not stare into an optical port.

Figure 2-1 Laser Product ID



⚠ Caution

Do not approach or stare into an optical port under any circumstances. This may cause permanent damage to your eyes.

2.3 Site Requirements

The equipment must be installed indoors for normal operation and prolonged service life.

The installation site must meet the following requirements.

2.3.1 Floor Loading

Assess the combined weight of the equipment and its accessories, such as rack, chassis, and power modules, and verify that the floor under the rack can bear the weight.

2.3.2 Airflow

The equipment adopts natural cooling. Reserve a sufficient clearance around the equipment to ensure proper ventilation.

2.3.3 Space

You are advised to have a pathway of at least 0.8 m (2.62 ft.) wide in the equipment room. This space ensures that you can move the chassis and swap the modules easily.

Do not install the equipment against a wall. Instead, maintain a minimum clearance of 10 cm (3.94 in.) around the equipment for heat dissipation and equipment maintenance.

2.3.4 Temperature and Humidity

To ensure the normal operation and a prolonged service life of the equipment, maintain an appropriate temperature and humidity in the installation environment.

Prolonged exposure to inappropriate temperature and humidity conditions can cause damage to the equipment.

- In an environment with high relative humidity, insulating materials are prone to poor insulation or even electricity leakage.
- In an environment with low relative humidity, insulating gaskets may shrink, resulting in screw loosening.
- In a dry environment, static electricity is more likely to occur, posing a risk to the internal circuits of equipment.
- A high temperature can accelerate the aging process of insulation materials, greatly reducing the availability of the equipment and severely affecting its service life.

2.3.5 Cleanliness

Dust poses a significant hazard to the equipment. Dust on the enclosure causes electrostatic adhesion, leading to poor contact of the metallic joints. Electrostatic adhesion is more likely to occur in an indoor environment with relatively low humidity, not only affecting the service life of the equipment, but also causing communication faults.

The following table lists the requirements for dust concentration and particle size in the equipment room.

Table 2-2 Requirements for Dust

Particle Diameter	Unit	Concentration
≥ 0.5 μm	Particles/m ³	≤ 3.5 × 10 ⁶
≥ 5 μm	Particles/m ³	≤ 3.5 × 10 ⁶

Apart from dust, there are also requirements on the salt, acid, and sulfide in the air of the equipment room. These harmful substances will accelerate metal corrosion and component aging. Therefore, the equipment room should be properly protected against harmful gases, such as sulfur dioxide, hydrogen sulfide, nitrogen dioxide, and chlorine gas. The following table lists the limits on harmful gases.

Table 2-3 Requirements for Gases

Gas	Average (mg/m ³)	Maximum (mg/m ³)
Sulfur dioxide (SO ₂)	0.3	1.0
Hydrogen sulfide (H ₂ S)	0.1	0.5
Nitrogen dioxide (NO ₂)	0.5	1.0
Chlorine gas (Cl ₂)	0.1	0.3

 **Note**

Average refers to the average value of harmful gases measured in a week. **Maximum** refers to the upper limit of harmful gases measured in a week for up to 30 minutes every day.

2.3.6 Grounding

A proper grounding system is crucial for ensuring stable and reliable operation, as well as preventing lightning strikes and interference. Carefully check the grounding conditions at the installation site according to the grounding requirements, and complete grounding properly based on the site situation.

- Safety Grounding

Ensure that the rack and power distribution system are securely grounded if the equipment uses the AC power supply. Otherwise, electric shocks may occur when the insulation resistance between the power module and the chassis decreases.

 **Caution**

- The building should provide a protective ground connection to ensure that the equipment is connected to a protective ground.
 - Verify that the AC socket is reliably connected to the protective grounding system of the building. If not, a protective grounding wire should be used to connect the protective grounding lug of the AC socket to the protective grounding system of the building.
-

- Lightning Grounding

The lightning protection system is an independent system composed of a lightning rod, a downlead conductor, and a connector connected to the grounding system. The grounding system is typically used for power reference grounding and safety grounding of the rack. Lightning grounding is required only for facilities, and is not required for the equipment.

- EMC Grounding

Electromagnetic compatibility (EMC) grounding includes shielded grounding, filter grounding, noise and interference suppression, and level reference.

2.3.7 Preventing Electromagnetic Interference

- Take interference prevention measures for the power supply system.
- Keep the equipment away from the grounding system or lightning protection grounding system of the power facility.
- Keep the equipment far away from high-frequency current equipment such as high-power radio transmitting stations and radar launchers.
- Take electromagnetic shielding measures when necessary.

2.3.8 Surge Protection

Although the equipment can guard against lightning strikes, strong lightning strikes may still damage the equipment. Take the following surge protection measures:

- Ensure that the grounding wire of the rack is in good contact with the ground.
- Ensure that the neutral point of the AC power socket is in good contact with the ground.
- Install a power arrester in front of the power input end to enhance surge protection for the power supply.

2.3.9 Installation Site

Regardless of whether the equipment is installed in a rack or on a workbench, ensure that the following conditions are met:

- Maintain a proper clearance around the air inlets and outlets for heat dissipation.
- Install the equipment in a standard 19-inch rack. Alternatively, place the equipment on a clean workbench. The installation of air conditioners is recommended in hot areas.
- The installation site has a good cooling and ventilation system.
- The installation site is sturdy enough to support the weight of the chassis and its accessories.
- The installation site is properly grounded.

2.4 Rack Requirements

If you plan to install the equipment in a rack, ensure that the rack meets the following conditions.

- (1) Use a four-post 19-inch rack.
- (2) The left and right square-hole rack posts are 465 mm (18.31 in.) apart.

Figure 2-2 19-Inch Rack

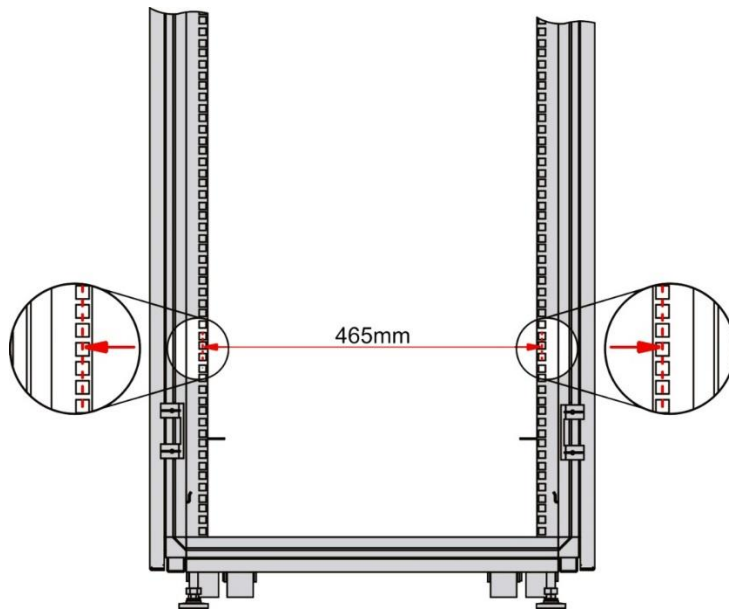

- (3) The square-hole rack post is at least 180 mm (7.09 in.) from the front door, and the front door is at most 25 mm (0.98 in.) thick. This ensures an available clearance of at least 155 mm (6.10 in.). The rack depth (distance between front and rear doors) is at least 1000 mm (39.37 in.).
- (4) The guide rails or tray can bear the weight of the equipment and its accessories.
- (5) The rack has a reliable grounding lug for the chassis to connect to earth ground.
- (6) The rack has a reliable ventilation system. The open area of front and rear doors is greater than 50%.

2.5 Tools

Table 2-4 Tools

Common Tools	Phillips screwdriver, cables, cage nuts, diagonal pliers, cable ties, and grounding wires
Dedicated Tools	Anti-ESD gloves, wire stripper, crimping pliers, RJ45 crimping pliers, and wire cutter
Meter	Multimeter

Note

The equipment is delivered without a toolkit. Prepare the preceding tools by yourself.

3 Installing the Switch

⚠ Caution

Before installing the equipment, ensure that guidelines and requirements in Chapter 2 have been met.

3.1 Before You Begin

- The installation site provides sufficient space for heat dissipation.
- The installation site meets the temperature and humidity requirements.
- The power supply is available at the installation site, and its current meets the requirements.
- The Ethernet cables have been deployed at the installation site.
- Locate the emergency power-off switch in the room before installation. In the case of an accident, cut off the power supply immediately.

3.2 Installing the Switch

3.2.1 Rack Mount

Install the RG-ES228GS-P-V2 switch in a standard 19-inch rack. The installation steps are as follows:

- (1) Take out the M4 x 8 mm cross recessed countersunk head screws delivered with the switch. Attach a rack-mount bracket to each side of the switch and secure it with three screws.

Figure 3-1 Securing Rack-Mount Brackets

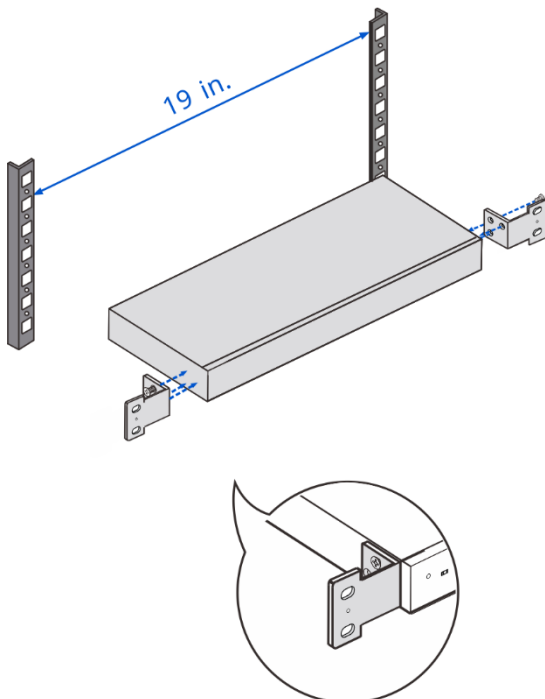

- (2) Horizontally position the switch at the desired location in the rack, and secure the other end of the rack-mount brackets to front square holes of the rack using four M6 screws and four cage nuts.

Figure 3-2 Installing the Switch in a Rack

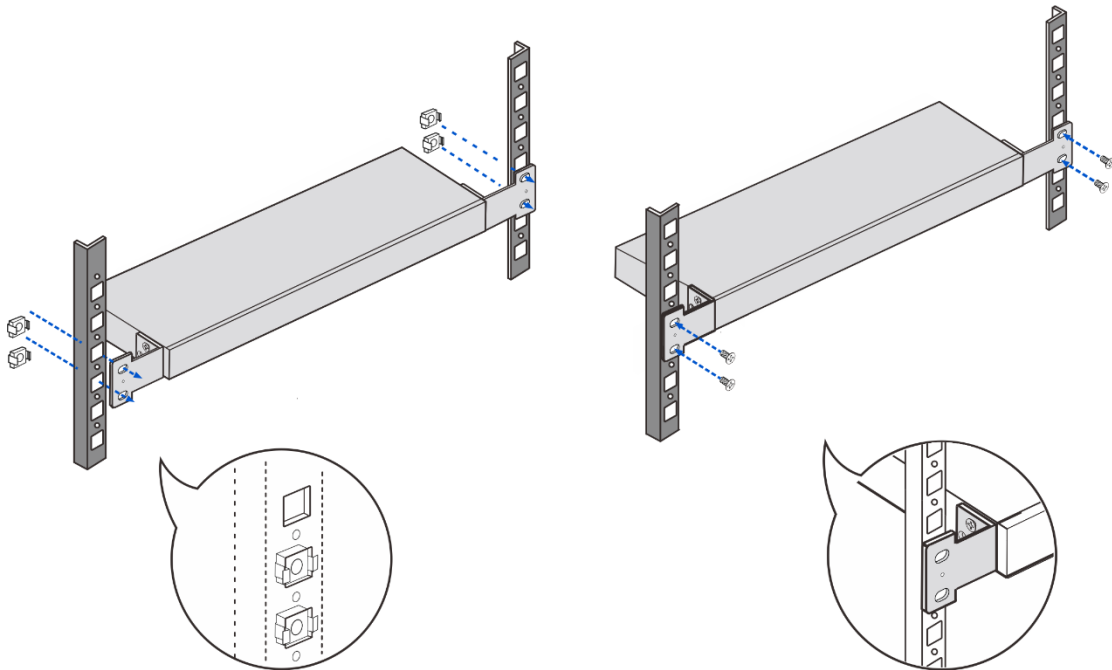

3.2.2 Workbench Mount

In most cases, users do not have a standard rack, and equipment can be placed on a clean workbench. The installation process is as follows:

- (1) Attach the four rubber pads in the package to the dents at the four corners on the bottom of the switch.

Figure 3-3 Attaching the Rubber Pads

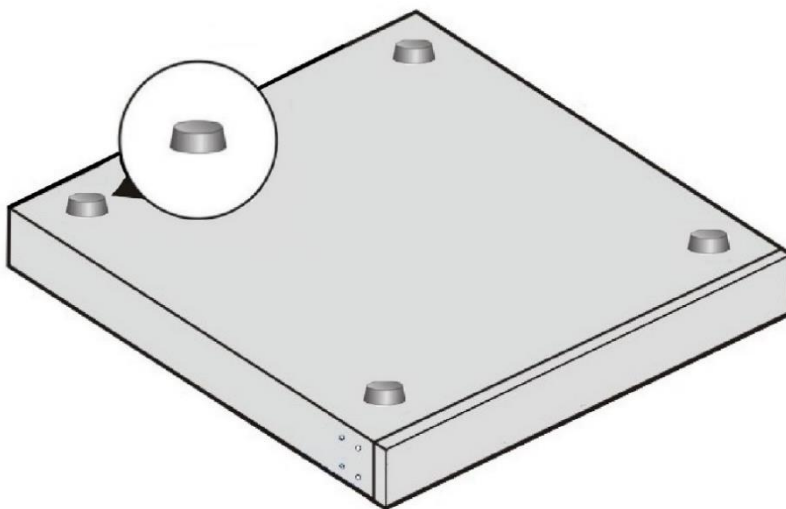

- (2) Place the equipment on a workbench.

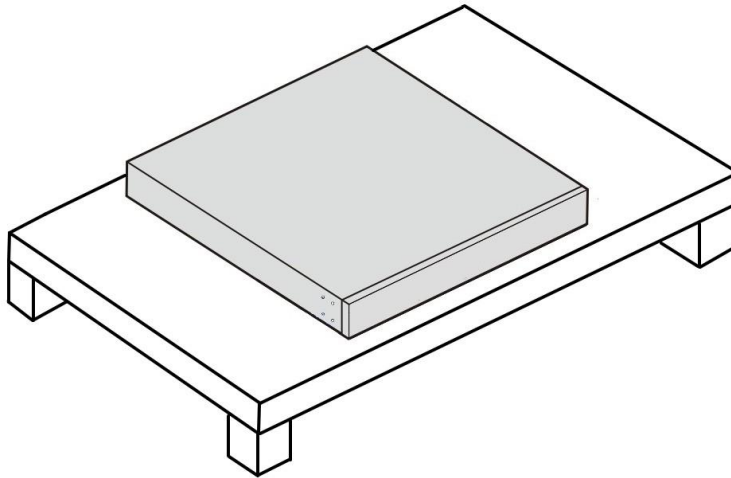
Figure 3-4 Placing the Equipment on a Workbench

3.3 Grounding the Equipment

Note

- If the equipment is installed on a workbench, connect the grounding wire to the nearest grounding bar or grounding point based on the onsite situation.
 - The grounding wire is not delivered with the equipment and needs to be purchased by the customer.
-

The equipment has a grounding stud on the rear panel. You are advised to connect the system grounding wire to it before using the equipment.

- (1) Purchase a grounding wire and connect one end to the grounding stud at the rear of the equipment.
- (2) Connect the other end to the grounding lug of the rack. Ensure the grounding lug of the rack has been connected to the grounding bar.

Caution

- To avoid personal injury and equipment damage, connect the switch to earth ground properly. The grounding resistance between the chassis and the ground should be less than 1 ohm.
 - The O&M personnel should verify whether the AC socket is reliably connected to the protective ground of the building. If not, the O&M personnel should use a protective grounding wire to connect the protective grounding lug of the AC socket to the protective ground of the building.
 - The power socket should be installed near the equipment and easily accessible.
 - During the equipment installation, connect the grounding wire first and disconnect it last.
 - The sectional area of a grounding wire should be determined according to the possible maximum current. Grounding wires with good conductors should be used.
 - Do not use bare wires.
-

3.4 Connecting Cables

Caution

- All cables must be routed indoors. Take surge protection measures if they need to be routed outdoors.
 - When connecting an optical cable, connect the transmit (TX) port on the local equipment to the receive (RX) port on the peer equipment, and vice versa.
-

After the switch is installed, connect the switch to other equipment according to the following steps:

- (1) Connect the power cord delivered with the switch to the power strip.
- (2) Connect the RJ45 connector of a twisted pair to an Ethernet port on the switch, and the other end to downlink equipment.
- (3) Insert an optical transceiver into the optical port first according to the panel identification. Then connect a single-mode fiber (SMF) or multimode fiber (MMF) to the corresponding optical transceiver, during which the transmitting and receiving ends of the optical cable should be distinguished.

3.5 Bundling Cables

3.5.1 Precautions

- Bundle the power cord and other cables in an esthetically pleasing way.
- Make sure that the optical cables at the connectors have natural bends or bends of large radius.
- Do not bind optical cables and twisted pairs too tightly, as this may press the cables and affect their service life and transmission performance.

3.5.2 Bundling Procedure

- (1) Bind the drooping part of the optical cables and twisted pairs, and lead them to both sides of the chassis for convenience.
- (2) On both sides of the chassis, fasten the optical cables and twisted pairs to the cable management ring or cabling chute.
- (3) Bind the power cord closely along the bottom of the chassis, in a straight line wherever possible.

3.6 Verifying Installation

Caution

Please turn off the power to avoid personal injury and damage to components caused by incorrect connection.

- Verify that the grounding wire is connected.
- Verify that the cables including power cords are properly connected.
- Verify that cables connected to ports are routed indoors.
- Verify that the surge protection socket and Ethernet port arrester are installed, if outdoor cabling exists.
- Verify that there is a minimum clearance of 10 cm (3.94 in.) around the switch.

4 Commissioning

4.1 Power-on

- (1) Checklist Before Power-on
 - The switch is properly grounded.
 - The power cord is properly connected.
 - The power supply voltage meets the requirement of the switch.
- (2) Checklist After Power-on (Recommended)
 - The switch LEDs are in the normal state.
 - Service ports can forward data properly.

4.2 Logging In to the Management Interface

- (1) Connect a PC to an Ethernet port on the switch through an Ethernet cable.
- (2) Set the IP address of the PC to 10.44.77.XXX (Range: 1–254, excluding 200).

Figure 4-1 Changing the IP Address

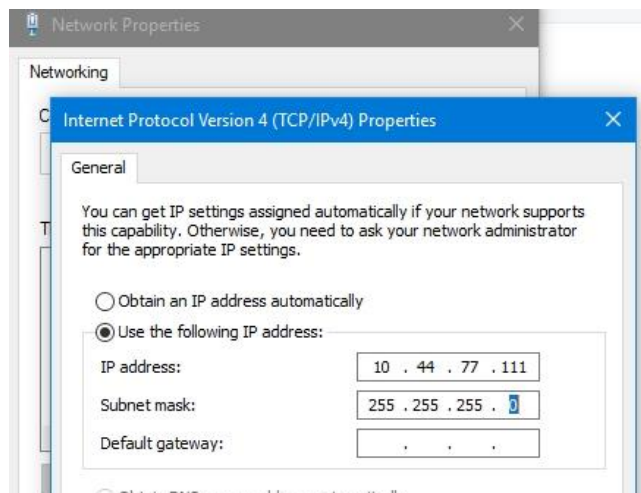

- (3) Open a browser, enter 10.44.77.200 in the address bar, and press Enter. On the login page, set a password and log in.
- (4) Perform equipment commissioning and configuration based on service requirements.

Note

For security purposes, you are advised to change the password regularly.

5 Troubleshooting

5.1 General Troubleshooting Flowchart

Note

You can determine whether each checking item in the process is normal based on the information provided in the previous chapters "Overview" and "Installing the Switch."

Figure 5-1 General Troubleshooting Flowchart

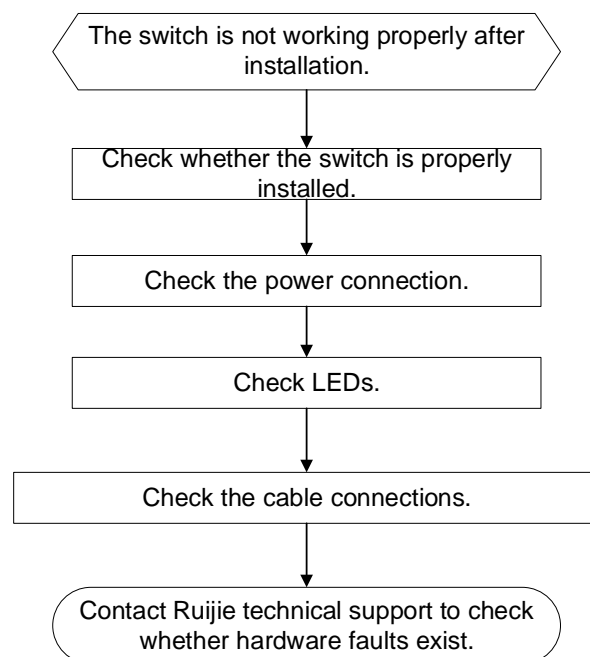

5.2 Common Faults

Table 5-1 Common Faults and Troubleshooting

Symptom	Possible Cause	Suggested Action
The system status LED is off after the switch is powered on.	No power is supplied to the switch or the power cord is loosely connected.	Check whether the power socket in the equipment room is normal and whether the power cord is loosely connected to the switch.
An RJ45 port is disconnected or a frame	The twisted pair is not connected properly.	Replace the twisted pair.

Symptom	Possible Cause	Suggested Action
sending/receiving error occurs.	The cable length exceeds 100 m (328.08 ft.).	Use an optical cable for data transmission or connect to an intermediate switch for relay.
	The port is specially configured and does not work in the same mode as that of the interconnected switch.	Check whether the port is configured to work in the same mode as that of the interconnected switch.
An optical port is not reachable.	The transmit and receive ends are connected incorrectly.	Exchange the transmit and receive ends of the optical cable.
	The types of the interconnected optical transceivers do not match.	Replace with one compatible optical transceiver.
	The optical cable type does not meet the requirements.	Replace the optical cable with a qualified one.
	The optical cable length is beyond the allowed length marked on the optical transceiver.	Use an optical cable with the required length.
	The optical cable or connector is contaminated.	Clean the connector with a lint-free cloth or a cleaning pen.
The login password cannot be retrieved.	The password is forgotten, and the equipment is not connected to the network or Ruijie Cloud.	Press and hold the Reset button to restore to factory settings.
	If the equipment is connected to Ruijie Cloud or a network, its login password is updated to the project or global management password.	If the equipment is connected to the cloud, log in using the project management password. If the equipment is connected to a network, log in using the global management password.
The Ethernet ports are transmitting and receiving frames normally, but their LEDs are off.	<p>The status of the Ethernet port LEDs is incorrectly displayed.</p> <p>The DIP switch is set to LED mode 2. As a result, the Ethernet port LEDs display the PoE status, but PoE is disabled on the ports.</p>	Set the DIP switch to LED mode 1 so that the Ethernet port LEDs display the data receiving and sending status.

6 Appendix

6.1 Connectors and Media

6.1.1 100r100Or1000BASE-T Port

The 10/100/1000BASE-T port supports auto-negotiation for 10 Mbps, 100 Mbps, and 1000 Mbps connections and also supports auto MDI/MDIX Crossover.

Compliant with IEEE 802.3ab, a 1000BASE-T port connects to a 100-ohm Category 5 (CAT5) or Category 5 Enhanced (CAT5e) Unshielded Twisted Pair (UTP), or recommended Shielded Twisted Pair (STP) cable with a maximum distance of 100 m (328.08 ft.).

The 1000BASE-T port requires that all four pairs of wires be connected for data transmission. [Figure 6-1](#) shows twisted pair connections for the 1000BASE-T port.

Figure 6-1 Twisted Pair Connections for a 1000BASE-T Port

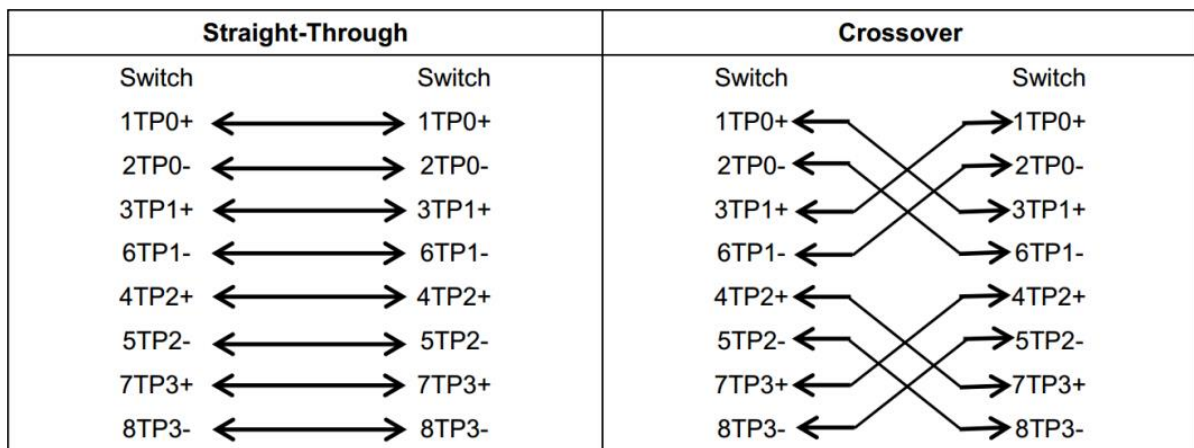

In addition to cables with the above-mentioned specifications, the 10/100BASE-T port can also be connected using 100-ohm CAT3, CAT4, and CAT5 cables at 10 Mbps or using 100-ohm CAT5 cables with a maximum distance of 100 m (328.08 ft.). The following table shows pin assignments for a 10/100BASE-T port.

Table 6-1 10/100BASE-T Pin Assignment

Pin	Socket	Plug
1	Input Receive Data+	Output Transmit Data+
2	Input Receive Data-	Output Transmit Data-
3	Output Transmit Data+	Input Receive Data+
6	Output Transmit Data-	Input Receive Data-
4, 5, 7, and 8	Not Used	Not Used

The following table shows wiring of straight-through and crossover cables for a 10/100BASE-T port.

Figure 6-2 Twisted Pair Connections for a 10/100BASE-T Port

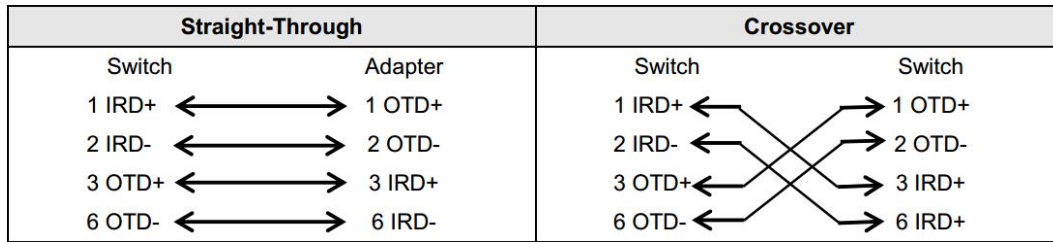

6.1.2 Optical Cable Connection

Select a single-mode fiber (SMF) or multimode fiber (MMF) for connections based on the type of the optical transceiver inserted into an optical port. [Figure 6-3](#) shows the connections.

Figure 6-3 Connecting the Optical Cables

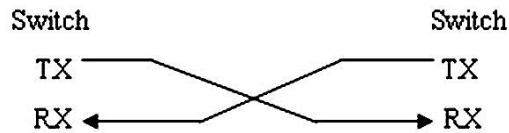

6.2 SFP Transceivers

Ruijie provides SFP transceivers (mini-GBIC) based on the port types. You can select one that suits your specific needs. In addition to the following 1GE SFP transceivers, the 1GE copper transceiver Mini-GBIC-GT is also supported. This document provides models and technical specifications of some 1GE SFP transceivers for reference. For details about the technical specifications, see *Ruijie Transceiver Installation and Reference Guide*.

Table 6-2 1GE Mini-GBIC (SFP) Models and Technical Specifications

Model	Wavelength (nm)	Fiber Type	DDM Supported (Yes/No)	Transmit Power (dBm)		Receive Power (dBm)	
				Min	Max	Min	Max
MINI-GBIC-SX-MM850	850	MMF	Yes	-9	-3	-20	-3
MINI-GBIC-LX-SM1310	1310	SMF	Yes	-9	-3	-26	0
GE-SFP-LH40-SM1310-BIDI	1310TX/1550RX	SMF	Yes	-3	3	-25	0
GE-SFP-LH40-SM1550-BIDI	1550TX/1310RX	SMF	Yes	-3	3	-25	0

GE-SFP-LX20-SM1310-BIDI	1310TX/1550RX	SMF	Yes	-8	-3	-23	-3
GE-SFP-LX20-SM1550-BIDI	1550TX/1310RX	SMF	Yes	-8	-3	-23	-3
MINI-GBIC-LH40-SM1310	1310	SMF	Yes	-5	0	-25	-3
MINI-GBIC-ZX80-SM1550	1550	SMF	Yes	-3	3	-26	-3
GE-SFP-LX03-SM1310-BIDI-I	1310TX/1550RX	SMF	Yes	-9	-3	-22	-3
GE-SFP-LX03-SM1550-BIDI-I	1550TX/1310RX	SMF	Yes	-9	-3	-22	-3
SFP-MM850	850	MMF	Yes	-9.5	-3	-17	-3
SFP-SM1310	1310	SMF	Yes	-9	-3	-20	-3

Table 6-3 1GE SFP Copper Transceivers

Standard	1000BASE-T SFP Module	DDM Supported (Yes/No)
1000BASE-T	Mini-GBIC-GT	No

Table 6-4 Cabling Specifications of SFP Transceivers

SFP Transceiver Model	Port Type	Fiber Type	Core Size (μm)	Max Cabling Distance
SFP-SM1310	LC	SMF	9/125	10 km (6.21 miles)
MINI-GBIC-LX-SM1310	LC	SMF	9/125	10 km (6.21 miles)
GE-SFP-LH40-SM1310-BIDI	LC	SMF	9/125	40 km (24.85 miles)
GE-SFP-LH40-SM1550-BIDI	LC	SMF	9/125	40 km (24.85 miles)
GE-SFP-LX20-SM1310-BIDI	LC	SMF	9/125	20 km (12.43 miles)
GE-SFP-LX20-SM1550-BIDI	LC	SMF	9/125	20 km (12.43 miles)
MINI-GBIC-LH40-SM1310	LC	SMF	9/125	40 km (24.85 miles)

SFP Transceiver Model	Port Type	Fiber Type	Core Size (µm)	Max Cabling Distance
				miles)
MINI-GBIC-ZX80-SM1550	LC	SMF	9/125	80 km (49.71 miles)
GE-SFP-LX03-SM1310-BIDI-I	LC	SMF	9/125	3 km (1.86 miles)
GE-SFP-LX03-SM1550-BIDI-I	LC	SMF	9/125	3 km (1.86 miles)
MINI-GBIC-SX-MM850	LC	MMF	62.5/125	275 m (902.23 ft.)
			50/125	550 m (1,804.46 ft.)
SFP-MM850	LC	MMF	62.5/125	275 m (902.23 ft.)
			50/125	550 m (1,804.46 ft.)
Mini-GBIC-GT	RJ45 Ethernet cable	CAT5 or better UTP or STP cable		100 m (328.08 ft.)

⚠ Caution

- For optical transceivers with a cabling distance of no less than 40 km (24.85 miles), install an optical attenuator to avoid overload on an optical receiver when using short-distance SMFs.
- An optical transceiver is a laser transmitter. Do not look into the light source to prevent it from burning your eyes.
- To keep the optical transceiver clean, make sure that the unused ports remain capped.

Table 6-5 BIDI Optical Transceiver Pairing

Rate/Distance	Pairing Model
1000 Mbps/3 km (1.86 miles)	<ul style="list-style-type: none"> ● GE-SFP-LX03-SM1310-BIDI-I ● GE-SFP-LX03-SM1550-BIDI-I
1000 Mbps/20 km (12.43 miles)	<ul style="list-style-type: none"> ● GE-SFP-LX20-SM1310-BIDI ● GE-SFP-LX20-SM1550-BIDI
1000 Mbps/40 km (24.85 miles)	<ul style="list-style-type: none"> ● GE-SFP-LH40-SM1310-BIDI ● GE-SFP-LH40-SM1550-BIDI

⚠ Caution

BIDI optical transceivers must be used in pairs. For example, if GE-SFP-LX20-SM1310-BIDI is used at one end, GE-SFP-LX20-SM1550-BIDI must be used at the other end.

6.3 Lightning Protection

6.3.1 Installing the AC Power Arrester (Power Strip with Surge Protection)

When an alternating current (AC) power cord is introduced from outdoors and directly connected to the AC power port of the switch, the power port must be connected to an external power arrester to safeguard the switch against lightning strikes. The power arrester can be fixed on the rack, workbench, or wall in the equipment room by using cable ties and screws. AC power enters the power arrester before entering the switch.

Figure 6-4 Power Arrester

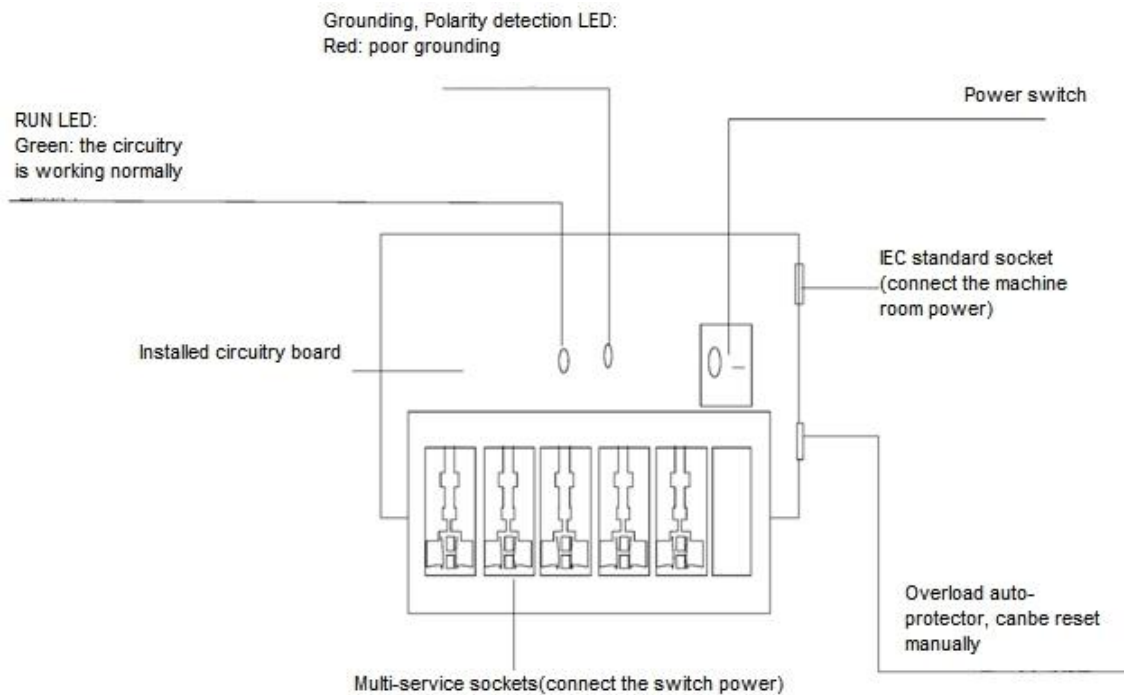

⚠ Caution

The power arrester is not delivered with the equipment. Please purchase it based on actual requirements.

Precautions during the installation:

- Make sure that the PE terminal of the power arrester is well grounded.
- After the AC power plug of the switch is connected to the socket of the power arrester, the lightning protection function is implemented only if the running status LED is green and the alarm LED is off.
- If the alarm LED on the power arrester is red, check whether it is caused by a poor grounding connection or

by the reversed connection of the neutral and live wires. The detection method is as follows: Use a multimeter to measure the polarity of the power arrester when the alarm LED is red. If the neutral wire is on the left and the live wire is on the right (facing the socket), the PE terminal of the power arrester is not grounded. If not, the polarity of the power arrester should be reversed. In this case, open the power arrester and reverse its polarity. If the alarm LED is still red, the PE terminal of the power arrester is not grounded.

6.3.2 Installing the Ethernet Port Arrester

Please connect an Ethernet port arrester to the switch to prevent the damage by lightning strikes before connecting an outdoor Ethernet cable to the switch.

- Tools: Phillips screwdriver or flat-blade screwdriver, multimeter, and diagonal pliers
- Installation steps
 - a Tear one side of the protective paper for the double-sided adhesive tape and paste the tape to the enclosure of the Ethernet port arrester. Tear the other side of the protective paper for the double-sided adhesive tape and paste the Ethernet port arrester to the switch enclosure. The paste position for the Ethernet port arrester should be as close to the grounding lug of the switch as possible.
 - b Based on the distance between the grounding lug of the switch and the Ethernet port arrester, cut the grounding cable of the Ethernet port arrester and firmly tighten the grounding cable to the grounding lug of the switch.
 - c Use a multimeter to check whether the grounding cable for the arrester is in good contact with the grounding lug and the enclosure of the switch.
 - d Connect the Ethernet port arrester by using an adapter cable (note that the external Ethernet cable is connected to the IN end, while the adapter cable connected to the switch is connected to the OUT end) and check whether the module LED is normal.
 - e Use a nylon cable tie to bind the cables.

Figure 6-5 Installing an Ethernet Port Arrester

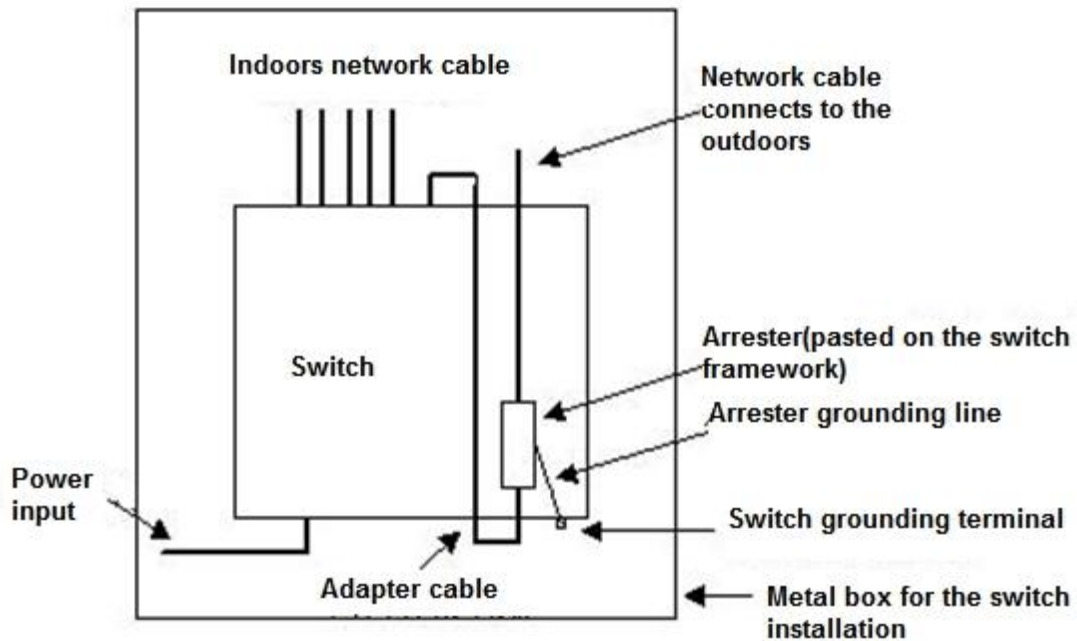

⚠ Caution

- The Ethernet port arrester is only for a 10 Mbps, 100 Mbps, or 1000 Mbps RJ45 port.
- The Ethernet port arrester is not delivered with the equipment. Please purchase it based on actual requirements. The user manual for Ethernet port arresters contains technical parameters and maintenance and installation instructions. Carefully read this manual during installation.

Pay attention to the following situations during the actual installation to avoid influencing the performance of an Ethernet port arrester:

- The arrester is incorrectly connected to the cables. Connect the external Ethernet cable to the IN end and connect the Ethernet port of the switch to the OUT end.
- The Ethernet port arrester is incorrectly grounded. The grounding cable of the arrester should be as short as possible to ensure that it is in good contact with the grounding lug of the switch. Use a multimeter to confirm the contact condition after grounding.
- Not all Ethernet ports are installed with Ethernet port arresters. If outdoor Ethernet cables connect the switch ports to the peer equipment, Ethernet port arresters need to be installed on all the ports for the purpose of lightning protection.

6.4 Recommended Cabling

When the switch is installed in a standard 19-inch cabinet, secure the cables around the cable management brackets. Top cabling or bottom cabling is adopted according to the actual situation in the equipment room. All adapted connectors should be placed at the bottom of the rack in an orderly manner instead of outside the rack that is easy to touch. Power cords are routed beside the rack. Top cabling or bottom cabling is adopted according

to the actual situation in the equipment room, such as the positions of the DC power distribution box, AC socket, or lightning protection box.

6.4.1 Requirement for the Minimum Bend Radius of Cables

- The bend radius of a fixed power cord, Ethernet cable, and flat cable should be over five times greater than their respective external diameters. The bend radius of these cables that are often bent or plugged should be over seven times greater than their respective external diameters.
- The bend radius of a fixed common coaxial cable should be over seven times greater than its external diameter. The bend radius of these cables that are often bent or plugged should be over 10 times greater than their respective external diameters.
- The minimum bend radius of a high-speed cable, such as an SFP+ cable, should be 5 times the overall diameter of the cable. If the cable is constantly bent, plugged or unplugged, the bend radius should be 10 times the overall diameter.
- The minimum bend radius of optical cables should meet the following requirements.
 - The diameter of the optical cable tray should be no less than 25 times greater than that of the optical cable.
 - When an optical cable is moved, its bend radius should be no less than 20 times greater than its diameter.
 - During cabling of an optical cable, its bend radius should be no less than 10 times greater than its diameter.

6.4.2 Precautions for Cable Bundling

- Before cables are bundled, mark labels and stick the labels to cables wherever appropriate.
- Cables should be neatly and properly bundled in the rack without twisting or bending, as shown in [Figure 6-6](#).

Figure 6-6 Bundling Cables (1)

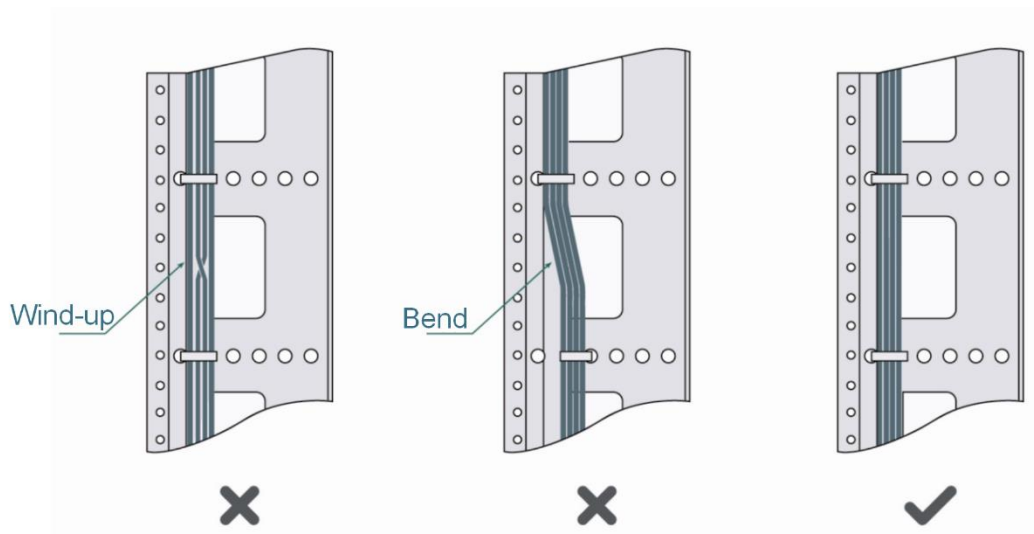

- Cables of different types (such as power cords, signal cables, and grounding wires) should be separated in cabling and bundling. Mixed bundling is not allowed. When they are close to each other, you are advised to

adopt crossover cabling. In the case of parallel cabling, maintain a minimum distance of 30 mm (1.18 in.) between power cords and signal cables.

- The cable management brackets and cabling troughs inside and outside the rack should be smooth without sharp corners.
- The metal holes traversed by cables should have a smooth and fully rounded surface or an insulated lining.
- Use cable ties to bundle cables properly. Please do not connect two or more cable ties to bundle cables.
- After bundling up cables with cable ties, cut off the remaining part. The cut should be smooth and trim without sharp corners, as shown in [Figure 6-7](#).

Figure 6-7 Bundling Cables (2)

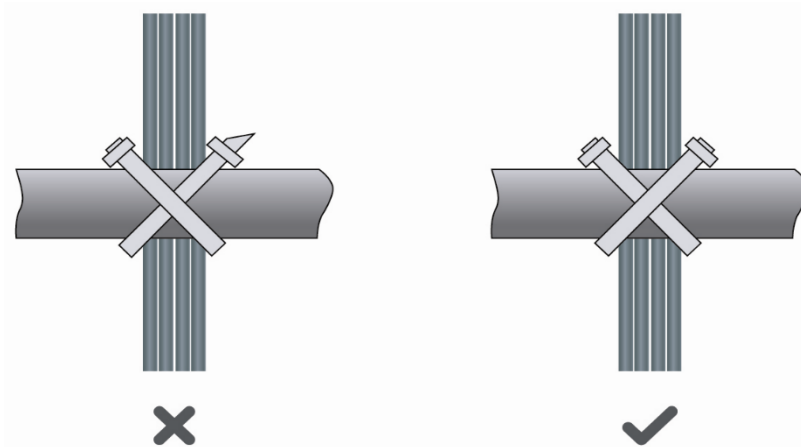

- When cables need to be bent, bundle them first but do not tie cables within the bend. Otherwise, stress may be generated on the cables and cause the wires inside to break, as shown in [Figure 6-8](#).

Figure 6-8 Bundling Cables (3)

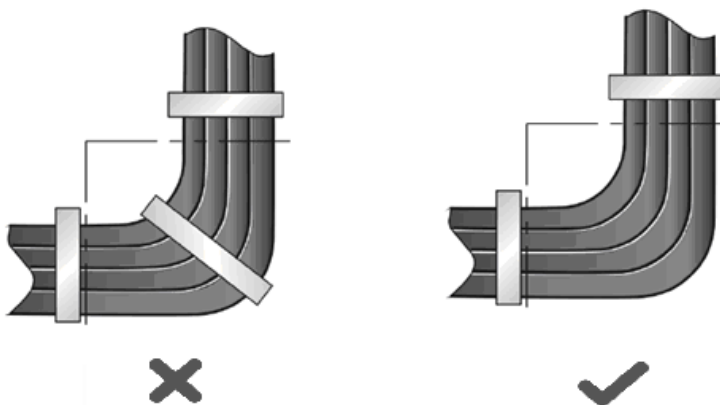

- Cables not to be assembled or the remaining parts of cables should be folded and placed in a proper position of the rack or cable management trough. The proper position refers to a position that does not affect the equipment running or damage the equipment or cables.
- Power cords must not be bundled on the guide rails of moving parts.
- The power cords connecting moving parts such as door grounding wires should be reserved with some

excess after being assembled to avoid suffering tension or stress. When a moving part reaches the installation position, the remaining cable part should not touch heat sources, sharp corners, or sharp edges. If heat sources must be touched, high-temperature cables should be used.

- When using screw threads to secure a cable lug, ensure that the bolt or screw is properly tightened and take measures to prevent it from loosening, as shown in [Figure 6-9](#).

Figure 6-9 Fastening Cables

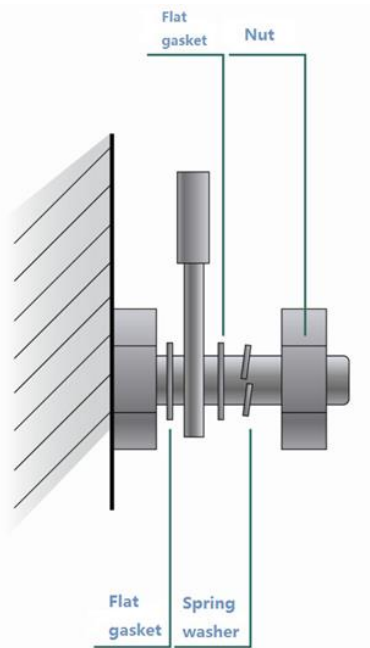

- Hard power cords should be secured near the cable termination area to prevent stress on the cable termination area and cables.
- Do not use tapping screws to secure cable lugs.
- Power cords of the same type and in the same cabling direction should be bundled up into cable bunches, with cables in cable bunches clean and straight.
- Bundle cables by using cable ties according to the following table.

Cable Bunch Diameter	Bundling Spacing
10 mm (0.39 in.)	80–150 mm (3.15–5.91 in.)
10–30 mm (0.39–1.18 in.)	150–200 mm (5.91–7.87 in.)
30 mm (1.18 in.)	200–300 mm (7.87–11.81 in.)

- Do not tie cables or bundles in a knot.
- For wiring terminal blocks (such as circuit breakers) with cord end terminals, the metal part of the cord end terminal should not be exposed outside the terminal block when assembled.

6.5 Site Selection

- The equipment room should be at least 5 km (3.11 miles) away from heavy pollution sources, such as smelters, coal mines, and thermal power plants. The equipment room should be at least 3.7 km (2.30 miles) away from medium pollution sources, such as the chemical factory, rubber factory, and electroplating factory. The equipment room should be at least 2 km (1.24 miles) away from light pollution sources, such as the food factory and leather plant. If the pollution source is unavoidable, the equipment room should be located on the windward side of the pollution source perennially with advanced protection.
- The equipment room should be at least 3.7 km (2.30 miles) away from the sea or salt lake. Otherwise, the equipment room must be sealed, with an air conditioner installed for temperature control. Saline soil cannot be used for construction. Otherwise, you should select equipment with advanced protection against severe environments.
- Do not build the equipment room in the proximity of livestock farms. Otherwise, the equipment room should be located on the windward side of the pollution source perennially. The previous livestock house or fertilizer warehouse cannot be used as the equipment room.
- The equipment room should be firm enough to withstand severe weather conditions such as windstorms, heavy rain, and dense dust. If the dust is unavoidable, keep the door and window away from the pollution source.
- The equipment falls into Class A. Therefore, the equipment room should be located away from the residential area. Otherwise, the equipment room should meet construction specifications to avoid noise and radio interference.
- Make sure the air vent of the equipment room is away from the sewage pipe, septic tank, and sewage treatment tank. Keep the equipment room under positive pressure to prevent corrosive gas from entering the equipment room to corrode components and circuit boards.
- Keep the equipment room away from industrial boilers and heating boilers.
- The equipment room should be on the second floor or higher. Otherwise, the equipment room floor should be 600 mm (23.62 in.) higher than the highest flood level ever recorded.
- Make sure no cracks or holes exist in the wall and floor. If there are cable entries in the wall or window, take proper sealing measures. Ensure that the wall is flat, wear-resistant, and dust-free, meeting standards for flame resistance, soundproofing, heat absorption, dust reduction, and electromagnetic shielding.
- Keep the door and the window closed to make the equipment room sealed.
- You are advised to use the steel door for soundproofing.
- Do not use sulfur-containing materials.
- Keep the air conditioner from blowing wind straight toward the equipment or blowing water drops from the window or air vent toward the equipment.

Contents

1 Change Description.....	1
1.1 1.0(1)B1P52.....	1
1.1.1 Hardware Change.....	1
1.1.2 Software Feature Change.....	1
2 Login.....	1
2.1 Configuration Environment Requirements	1
2.2 Connecting the Device.....	1
2.3 Login to eWeb.....	1
3 Port Management.....	4
3.1 Managing Port Information	4
3.1.1 Port Status Bar.....	4
3.1.2 Port Info Overview	5
3.1.3 Port Packet Statistics	6
3.2 Port Settings	6
3.3 Port Aggregation.....	8
3.3.1 Overview	8
3.3.2 Configuring a Static Aggregate Interface.....	9
3.3.3 Configuring Load Balancing Algorithms.....	12
3.4 Port Mirroring	13
3.4.1 Overview	13
3.4.2 Configuration Steps	13
3.5 Port Isolation.....	14
3.6 Port-based Rate Limiting	15

3.7 Management IP Address	16
4 Switch Settings.....	17
4.1 Managing MAC Address.....	17
4.1.1 Overview	17
4.1.2 Viewing MAC Address Table.....	17
4.1.3 Searching for MAC Address	17
4.1.4 Configuring Static MAC Address	18
4.2 VLAN Settings.....	19
4.2.1 Global VLAN Settings	19
4.2.2 Static VLANs Settings.....	20
4.2.3 Port VLAN Settings.....	20
5 Security.....	22
5.1 DHCP Snooping.....	22
5.1.1 Overview	22
5.1.2 Configuration Steps	22
5.2 Storm Control.....	22
5.2.1 Overview	22
5.2.2 Configuration Steps	22
5.3 Loop Guard	23
6 PoE Settings.....	24
6.1 PoE Information	24
6.2 PoE Settings	24
6.2.1 PoE In Settings	24
6.2.2 PoE watchdog.....	25

6.2.3 PoE Port Restart Scheduler.....	25
6.2.4 Perpetual PoE	26
7 ERPS.....	27
7.1.1 Overview	27
7.1.2 Control VLAN and Data VLAN.....	27
7.1.3 Basic Model of an Ethernet Ring	27
7.1.4 RPL and Nodes.....	29
7.1.5 ERPS Packet	31
7.1.6 ERPS Timer	31
7.1.7 Ring Protection	31
7.1.8 Protocols and Standards	32
7.1.9 Configuring ERPS.....	32
8 Toolkit	35
8.1 PING	35
8.2 Cloud Settings.....	35
8.2.1 Checking the Cloud Information	35
8.2.2 Introduction to CoAP.....	36
8.2.3 Configuring CoAPs-based Encryption	36
8.3 System Logs	41
9 System Settings	42
9.1 Managing Device Information.....	42
9.1.1 Viewing Device Information	42
9.1.2 Editing the Hostname.....	42
9.1.3 Cloud Management.....	42

9.2 Login Password Settings	43
9.3 Device Reboot	44
9.4 System Upgrade	45
9.4.1 Local Upgrade.....	45
9.4.2 Online Upgrade.....	45
9.5 Restoring Factory Configuration.....	46
10 Monitoring.....	47
10.1 Cable Test.....	47
10.2 Multi-DHCP Alarming.....	47
10.3 Viewing Switches on the Network	48
11 FAQs.....	49
11.1 I failed to log in to eWeb. What can I do#.....	49
11.2 What can I do if I forget my password# How can I restore the factory settings#.....	49

1 Change Description

This chapter describes the major changes in software and hardware of different versions and related documentation. For details about hardware changes, see the release notes published with software versions.

1.1 1.0(1)B1P52

1.1.1 Hardware Change

The following table lists the hardware models supported by this version.

Table 1-1 Supported Hardware Models

Model	Hardware Version Number
RG-ES205GC-V2	1.0x
RG-ES207GS-AC-OD	1.0x
RG-ES207GS-HP	1.0x
RG-ES207GS-LP	1.0x
RG-ES207GS-PI-OD	1.0x
RG-ES207GS-P	1.0x
RG-ES208GC-V2	1.0x
RG-ES211GS-LP	1.0x
RG-ES211GS-P	1.0x
RG-ES216GC2MS	1.0x
RG-ES220GS-P-V2	1.0x
RG-ES224GC2MS	1.0x
RG-ES228GS-P-V2	1.0x

1.1.2 Software Feature Change

Note

New features refer to those supported from ESW_1.0(1)B1P52.

Table 1-2 Changed Features

Change Content	Change Description
Aggregate interface	The RG-ES2 series switches support port aggregation. For details, see 3.3 Port Aggregation .
Ping	The RG-ES2 series switches support the ping tool. For details, see 8.1 PING .
Perpetual PoE	The Perpetual PoE feature can be enabled on PoE switches to ensure an uninterrupted PoE power supply during a switch restart. For details, see 6.2.4 Perpetual PoE .
PoE Port Restart Scheduler	You can check the configuration status of the PoE Port Restart Scheduler feature on eWeb of the RG-ES2 series switches. For details, see 6.2.3 PoE .
PoE In	The RG-ES207GS-PI-OD switch can be powered through a PoE In port. When the switch adopts the power mode and the uplink Power Sourcing Equipment (PSE) provides insufficient power to support the PoE output of the switch, the PoE output will be unavailable. For details, see 6.2 PoE .
ERPS	The RG-ES2 series switches support Ethernet Ring Protection Switching (ERPS). For details, see 7 ERPS .
Encryption Mode	The Encryption Mode(coaps) feature can be configured to improve data transmission security. For details, see 8.2 Cloud Settings .

2 Login

2.1 Configuration Environment Requirements

- Google Chrome and Microsoft Edge are supported. Exceptions such as garbled characters or format errors may occur when other browsers are used.
- 1024 x 768 or a higher resolution is recommended. Exceptions such as font alignment errors and format errors may occur when other resolutions are used.

2.2 Connecting the Device

Connect the switch port with the network port of the PC through an Ethernet cable. Configure the PC to obtain an IP address automatically via DHCP, or manually assign a static IP address within the same subnet as the device, avoiding IP conflicts. Ensure that the PC can reach the switch using the ping command. For example, you can set the PC's IP address to 10.44.77.XXX (range: 1–254, excluding 200).

Table 2-1 Default Configuration

Feature	Default Setting
Device IP Address	10.44.77.200
Password	admin

2.3 Login to eWeb

- (1) Enter the IP address (10.44.77.200 by default) of the device in the address bar of the browser to access the login page.

Note

If the static IP address of the device is changed, or the device dynamically obtains a new IP address, the new IP address can be used to access the device's eWeb as long as the PC and the device are on the same LAN, and their IP addresses are on the same network segment.

- (2) (Optional) When logging in for the first time, set the login password and click **Save**.

Figure 2-1 Login to eWeb Upon the First Time

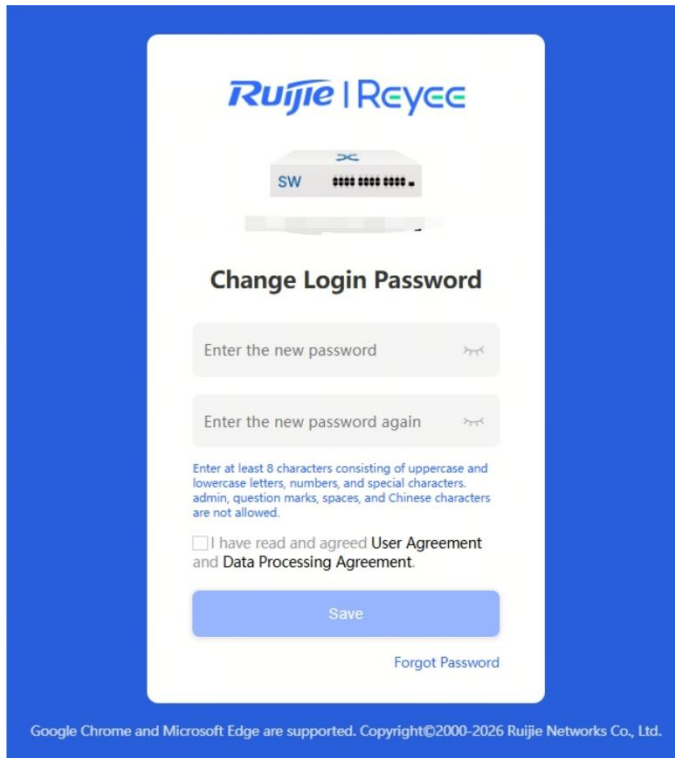

(3) On the login page, enter the password and click **Log In** to enter the homepage of eWeb.

Note

To change the login password, see [9.2 Login Password Settings](#).

Figure 2-2 eWeb Login Page

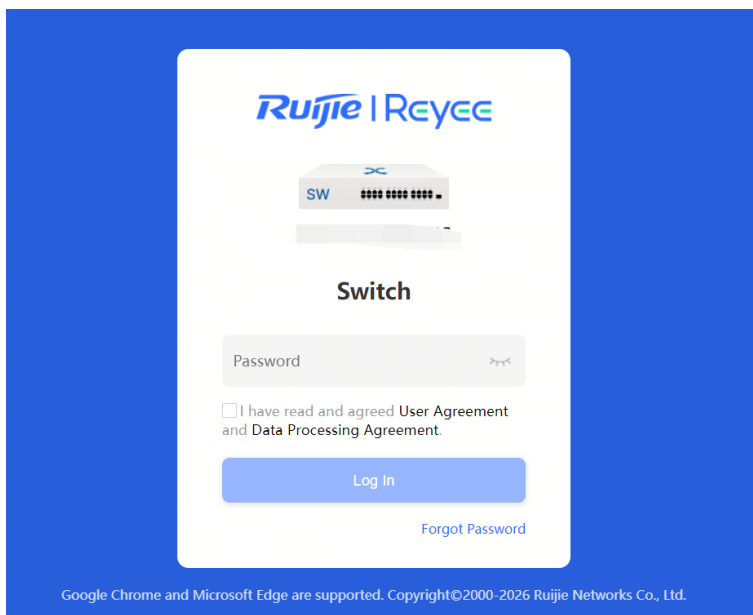

If you forget the device's IP address or password, hold down the **Reset** button on the device panel for more than 5 seconds to restore factory settings when the device is connected to the power supply. After restoration, you can use the default IP address to log in to the device and then change the login password.

Caution

Restoring factory settings will clear all configurations on the device. Exercise caution when performing this operation.

3 Port Management

3.1 Managing Port Information

3.1.1 Port Status Bar

The port status bar is at the top of eWeb, showing the port ID, port attribute (uplink/downlink), connection status, and other information.

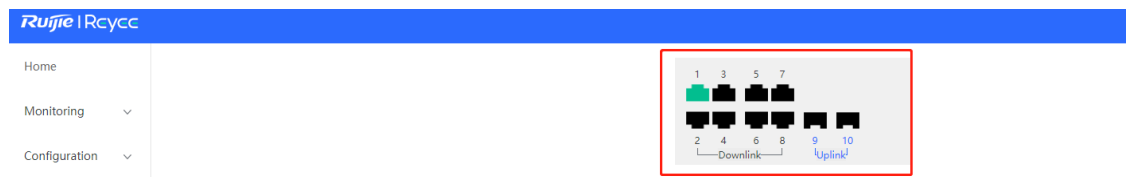
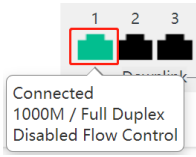

Figure 3-1 Port Status Bar



Different colors and shapes of the port icons represent different port statuses. See [Table 3-1](#) for details. Move the cursor over a port icon and the port status will be displayed, including the connection status, port rate, duplex mode, and flow control status.

Table 3-1 Port Icons

Port Icon	Description
	The port icon is in the shape of a square, showing the port is a fiber port.
	The port icon is in the shape of an RJ-45 connector, showing the port is a copper port.
	The number in the lower right corner of the port icon shows a port number. This port icon indicates that the port is a member port of an aggregate interface.
	The color of the port icon is black, showing the port is disconnected.
	The color of the port icon is gray, showing the port is disabled and cannot receive or transmit packets.
	The color of the port icon is yellow, showing there is a loop.

Port Icon	Description
	<p>The color of the port icon is green, showing the port is working normally.</p>
	<p>The number above the port icon is the port ID used to identify the device port. With the port ID, you can specify the target port.</p>
	<ul style="list-style-type: none"> ● The device port is classified into the uplink port and the downlink port. The uplink port is used to connect network devices in the upper layer and access the core network. The downlink port is used to connect the endpoints. ● When port isolation is enabled, the downlink ports of the device are isolated from each other, and they can only communicate with the uplink ports. For details, see 3.5 Port Isolation

3.1.2 Port Info Overview

Choose **Home** from the navigation page.

The **Home** page displays the global port information, including the port status, port VLAN settings, packet receiving/transmission rate (Rx/Tx rate), port isolation status, loop status, and port PoE settings. In addition, you can query and view information about downlink devices.

Click a port feature to go to the feature configuration page.

- Click **Port Status** to configure the basic port attributes. For details, see [3.2 Port Settings](#).
- Click **VLAN** to set the VLAN of the port. For details, see [4.2 VLAN Settings](#).

Note

Port VLAN settings can only be configured and viewed in the **Port Info** pane after the **VLAN Settings** switch is toggled on.

- Click **Isolation Status** to configure port isolation so that the downlink ports of the device are isolated from each other. For details, see [3.5 Port Isolation](#).
- Click **Loop Status** to enable loop guard function. After a loop occurs, the port causing the loop will be shut down automatically. For details, see [5.3 Loop Guard](#).
- Click **PoE** to view and set PoE parameters of the port. For details, see [6 PoE Settings](#).

Note

The PoE information will be shown in the port information list only when the devices support PoE.

- Click **Search** in the **Downlink Device** column to search for the downlink device of the selected port. After the search is done, click **View** to view the MAC address of the downlink device.
- Click **Refresh List** to fetch the latest port information.

Figure 3-2 Viewing or Configuring Port Settings

Port Info VLAN settings Refresh List

Port	Status	Config Status		Actual Status	Port Status				VLAN				Rx/Tx Rate (kbps)	Isolation Status	Loop Status	PoE		Downlink Device Search
		Speed	Duplex		Flow Control(Config)	Flow Control(Actual)	EEE(Config)	EEE(Actual)	Type	Access	Native	Permit				PoE Power	Action	
Port 1	Enabled	Auto	Auto	1000M/Full Duplex	Disabled	Disabled	Disabled	Disabled	Access	1	--	--	14/6	Unisolated	Normal	--	--	--
Port 2	Enabled	Auto	Auto	Disconnected	Disabled	Disabled	Disabled	Disabled	Access	1	--	--	0/0	Unisolated	Normal	--	--	--
Port 3	Enabled	Auto	Auto	Disconnected	Disabled	Disabled	Disabled	Disabled	Access	1	--	--	0/0	Unisolated	Normal	--	--	--
Port 4	Enabled	Auto	Auto	Disconnected	Disabled	Disabled	Disabled	Disabled	Access	1	--	--	0/0	Unisolated	Normal	--	--	--
Port 5	Enabled	Auto	Auto	Disconnected	Disabled	Disabled	Disabled	Disabled	Access	1	--	--	0/0	Unisolated	Normal	--	--	--
Port 6	Enabled	Auto	Auto	Disconnected	Disabled	Disabled	Disabled	Disabled	Access	1	--	--	0/0	Unisolated	Normal	--	--	--
Port 7	Enabled	Auto	Auto	Disconnected	Disabled	Disabled	Disabled	Disabled	Access	1	--	--	0/0	Unisolated	Normal	--	--	--
Port 8	Enabled	Auto	Auto	Disconnected	Disabled	Disabled	Disabled	Disabled	Access	1	--	--	0/0	Unisolated	Normal	--	--	--
Port 9	Enabled	Auto	Auto	Disconnected	Disabled	Disabled	Unsupported	Unsupported	Trunk	--	1	1,4001	0/0	Unisolated	Normal	PoE Unsupported	--	--
Port 10	Enabled	Auto	Auto	Disconnected	Disabled	Disabled	Unsupported	Unsupported	Trunk	--	1	1,4001	0/0	Unisolated	Normal	PoE Unsupported	--	--

3.1.3 Port Packet Statistics

Choose **Monitoring > Port Statistics**.

The **Port Statistics** page displays the port status, the connection status, Rx/Tx rate (kbps), Rx/Tx packets (KB), Rx/Tx success, and Rx/Tx failure.

Click **Clear** to clear current packet statistics of all ports and reset the statistics.

Figure 3-3 Port Packet Statistics

Port Statistics

Port	Status	Connection Status	Rx/Tx Rate(kbps)	Rx/Tx Packets(KB)	Rx/Tx Success	Rx/Tx Failure
Port 1	Enabled	Connected	31/218	126708/6759	657071/20802	0/0
Port 2	Enabled	Disconnected	0/0	0/0	0/0	0/0
Port 3	Enabled	Disconnected	0/0	0/0	0/0	0/0
Port 4	Enabled	Disconnected	0/0	0/0	0/0	0/0
Port 5	Enabled	Disconnected	0/0	0/0	0/0	0/0
Port 6	Enabled	Disconnected	0/0	0/0	0/0	0/0
Port 7	Enabled	Disconnected	0/0	0/0	0/0	0/0
Port 8	Enabled	Disconnected	0/0	0/0	0/0	0/0
Port 9	Enabled	Disconnected	0/0	0/0	0/0	0/0
Port 10	Enabled	Disconnected	0/0	0/0	0/0	0/0

3.2 Port Settings

Note

- Conditions for enabling Energy Efficient Ethernet (EEE): The local port is an RJ45 port, the port rate is 100 Mbps or 1000 Mbps, the duplex mode is set to **Auto**, and the EEE feature is enabled on the peer port.
- Optical ports do not support the EEE feature.

Choose **Configuration > Port Settings**.

You can set the basic attributes of the Ethernet ports in batches.

- (1) Click **Select** in the **Port** column to display options of all device ports. Select the ports you want to configure.
- (2) Set the feature parameters for the ports.
- (3) Click **Save**.

The port list below provides the basic attributes of all ports and can also be used to verify whether the configuration of a specified port takes effect.

Caution

Shutting down all ports will make the switch unmanageable. Exercise caution when performing this operation.

Figure 3-4 Port Configuration and Status

Port Settings

After the port is shut down, it is not allowed to send or receive packets(PoE is not affected). Shutting down all ports will make the switch unmanageable. Please be cautious.

Port	Status	Speed	Duplex	Flow Control	EEE
1 Port 3	2 Enabled	Auto	Auto	Disabled	Enabled

3 Save

Port List

Port	Status	Speed/Duplex		Flow Control		EEE	
		Config Status	Actual Status	Config Status	Actual Status	Config Status	Actual Status
Port 1	Enabled	10M/Auto	10M/Full Duplex	Enabled	Disabled	Disabled	Disabled
Port 2	Enabled	10M/Auto	Disconnected	Enabled	Disabled	Disabled	Disabled
Port 3	Enabled	10M/Auto	Disconnected	Enabled	Disabled	Disabled	Disabled
Port 4	Enabled	10M/Auto	Disconnected	Enabled	Disabled	Disabled	Disabled
Port 5	Enabled	10M/Auto	Disconnected	Enabled	Disabled	Disabled	Disabled
Port 6	Enabled	10M/Auto	Disconnected	Enabled	Disabled	Disabled	Disabled
Port 7	Enabled	100M/Full Duplex	100M/Full Duplex	Enabled	Enabled	Disabled	Disabled
Port 8	Enabled	100M/Full Duplex	100M/Full Duplex	Enabled	Enabled	Disabled	Disabled
Port 9	Enabled	Auto/Auto	Disconnected	Disabled	Disabled	Unsupported	Unsupported
Port 10	Enabled	Auto/Auto	Disconnected	Disabled	Disabled	Unsupported	Unsupported

Table 3-2 Basic Port Configuration Parameters

Parameter	Description	Default
Port	Select the ports you want to configure.	No default value
Status	<ul style="list-style-type: none"> ● Enabled: When the port is enabled, it can receive or transmit packets. ● Disabled: When the port is disabled, it cannot receive or transmit packets (The PoE feature of the ports will not be affected). 	Enabled
Speed	Configure the operating speed of the Ethernet physical port. When the speed is set to Auto , it is determined by the auto-negotiation between the local port and the peer port. The negotiated speed can be any speed within the port capability.	Auto
Duplex	<ul style="list-style-type: none"> ● Full Duplex: The port can receive packets while sending packets. ● Half Duplex: The port can receive or send packets at a time. ● Auto: The duplex mode of the port is determined by the auto-negotiation between the local port and the peer port. 	Auto
Flow Control	When Flow Control is set to Enabled , the port will process the received flow control frames and send them when flow congestion occurs.	Disabled

Parameter	Description	Default
EEE	When Energy Efficient Ethernet (EEE) based on the IEEE 802.3az standard is enabled on an Ethernet port and the port is in idle state, it enters the Low Power Idle (LPI) mode, thereby achieving energy saving.	Disabled

3.3 Port Aggregation

3.3.1 Overview

1. Aggregate Interface Overview

An aggregate interface can bind multiple physical links to form a logical link, expanding link bandwidth and improving link reliability.

- Expanding link bandwidth: If a link between two devices supports a maximum bandwidth of 1,000 Mbps (assuming that 1,000 Mbps ports are used on both devices), and the service traffic carried by the link exceeds 1,000 Mbps, the excessive traffic will be discarded. Aggregate interfaces can be used to solve the issue. For example, use n Ethernet cables to connect the two devices and bind the ports together to become an aggregate interface. In this way, the aggregate interface supports the maximum traffic of $1000 \text{ Mbps} \times n$.
- Improving link reliability: If the two devices are connected by only one Ethernet cable and the link is disconnected, services carried by the link will be interrupted. However, if the two devices are connected by multiple cables and the connected ports are aggregated, the service traffic can be transmitted properly as long as one link remains connected.

2. Static Aggregate Interfaces

A static aggregate interface is a logical interface configured by manually binding multiple physical ports. Each physical port is called a member port of the static aggregate interface. The static aggregate interface is easy to configure. You can add specified physical ports to the same static aggregate interface to aggregate multiple physical links. After a member port is added to a static aggregate interface, the port starts to send and receive data on the aggregate interface and is controlled by the load balancing algorithm configured on the aggregate interface.

3. Load Balancing

Link aggregation, based on packet features such as the source MAC address, destination MAC address, source IP address, destination IP address, Layer 4 source port number, and Layer 4 destination port number of packets received by an inbound interface, differentiates packet flows according to one or several combined algorithms. Link aggregation sends the same packet flow over the same member link, and evenly distributes different packet flows among member links. For example, in source MAC-based load balancing mode, packets are distributed to member ports of the aggregate interface based on the source MAC addresses of the packets. Packets with different source MAC addresses are evenly distributed among member ports, while those with the same source MAC address are forwarded through the same member port.

Load balancing is performed on aggregate interfaces based on the following packet features.

- Src & Dest MAC

- Src MAC
- Src IP
- Src L4 Port
- Src Port
- Dest MAC
- Dest IP Address
- Dest L4 Port
- Src & Dest IP Address
- Src & Dest L4 Port

3.3.2 Configuring a Static Aggregate Interface

Choose **Configuration > Port Aggregation**.

1. Adding an Aggregate Interface

Note

- The maximum number of aggregate interfaces that can be created varies with the device model. Please refer to the maximum number shown on the configuration page.
- An aggregate interface contains a maximum of four member ports.
- Due to chip limitations, devices with 5–7 ports support a maximum of two aggregate interfaces. Aggregate interface 1 uses ports 1 to 4, while aggregate interface 2 uses ports 5 to 7. The actual member ports of aggregate interface 2 depend on the available physical ports. For example, if the device has only five ports, port 5 will be the only member port of aggregate interface 2. The switches with 5–7 ports include the RG-ES205GC-V2, RG-ES207GS-P, RG-ES207GS-LP, RG-ES207GS-HP, RG-ES207GS-AC-OD, and RG-ES207GS-PI-OD.
- The attributes of member ports must be consistent. An RJ45 port and an optical port cannot be aggregated.
- **Load Balance Algorithm** is set to **Src & Dest MAC** by default.

- (1) Set Aggregate Port to Ag1 or Ag2.
- (2) Select member ports, each of which can be added to only one aggregate interface, and click **Save**.

Figure 3-5 Adding an Aggregate Interface

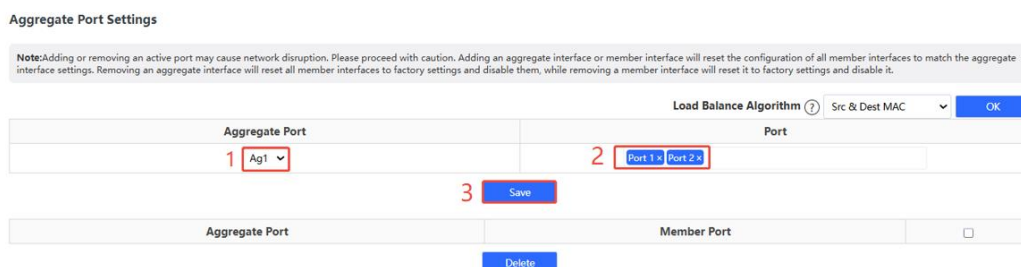

- (3) Read the message in the pop-up window, and click **OK**.

Figure 3-6 Secondary Confirmation Pop-up Window for Adding an Aggregate Interface

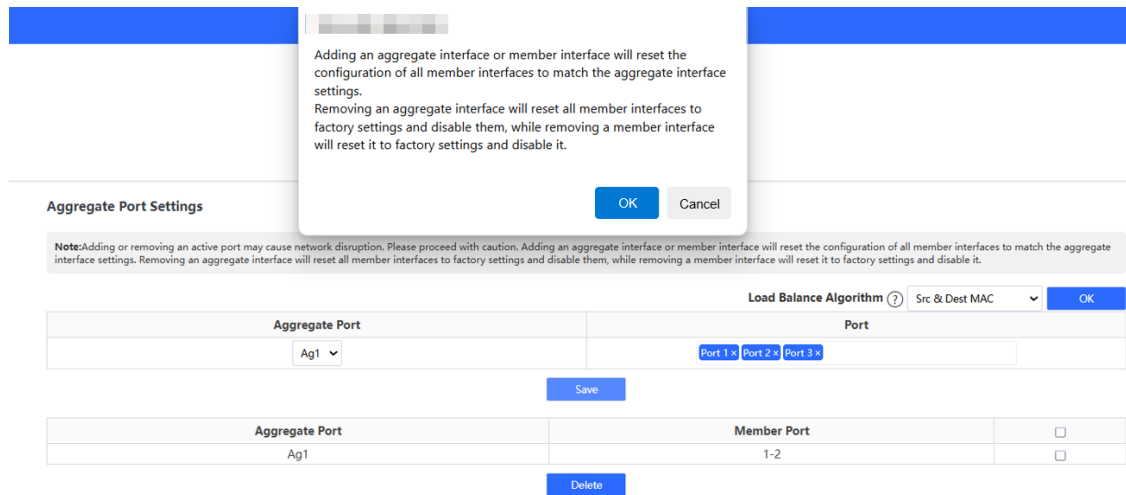

Caution

- Exercise caution when configuring a running port as a member port of an aggregate interface, as this operation may cause network interruption.
- When an aggregate interface is added, the configuration of its member ports will be reset and the configuration of the aggregate interface is applied to them.

Information about the configured aggregate interfaces is displayed in the lower part of the page. You can also check the aggregate interface information in the port status bar at the top of the page.

Figure 3-7 Aggregate Interface Information in the Lower Part of the Page

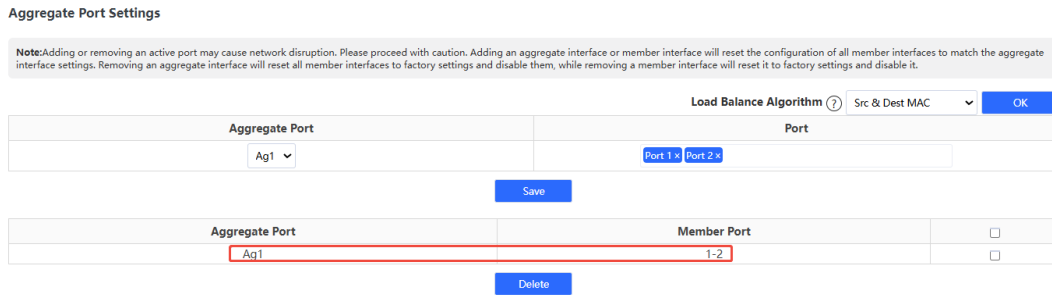
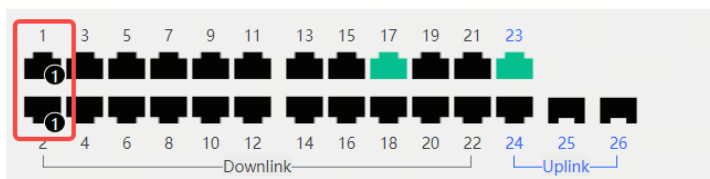

Figure 3-8 Aggregate Interface Information in the Port Status Bar at the Top of the Page



2. Modifying Member Ports of an Aggregate Interface

Caution

- You cannot select ports that have been added to other aggregate interfaces.
- When a member port is added to an aggregate interface, the configuration of the member port is reset and the configuration of the aggregate interface is applied to it.
- When a member port is removed from an aggregate interface, the port is restored to factory settings and disabled.

- (1) Select the name of an aggregate interface whose member ports need to be modified. The member ports of the aggregate interface are automatically displayed.
- (2) Click **Port**, and select or deselect member ports in the displayed drop-down list (adding member ports as an example).
- (3) Click **Save**, read the message in the pop-up window, and click **OK**.

Figure 3-9 Modifying Member Ports of an Aggregate Interface

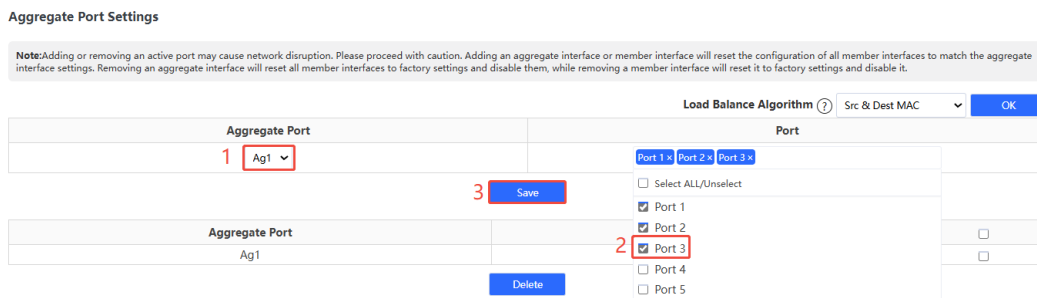
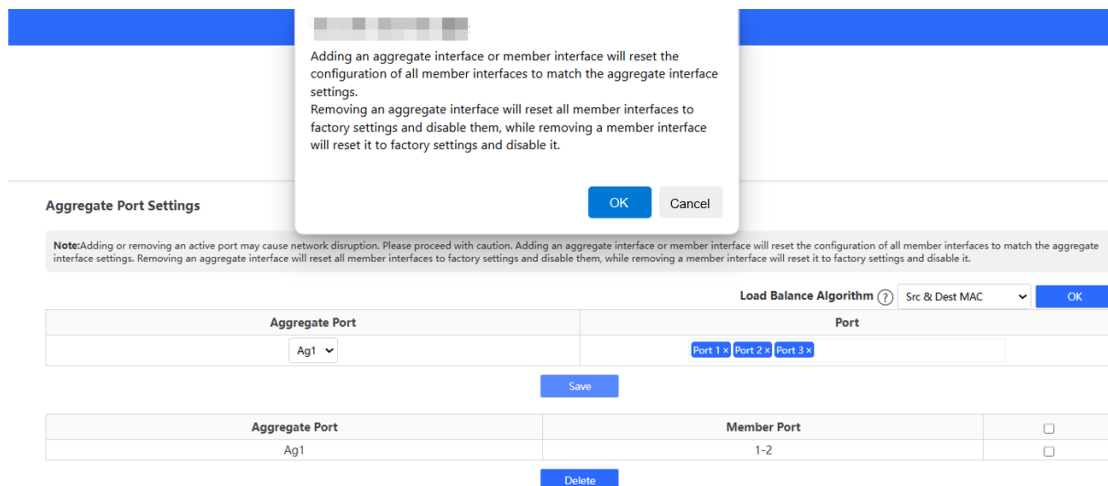
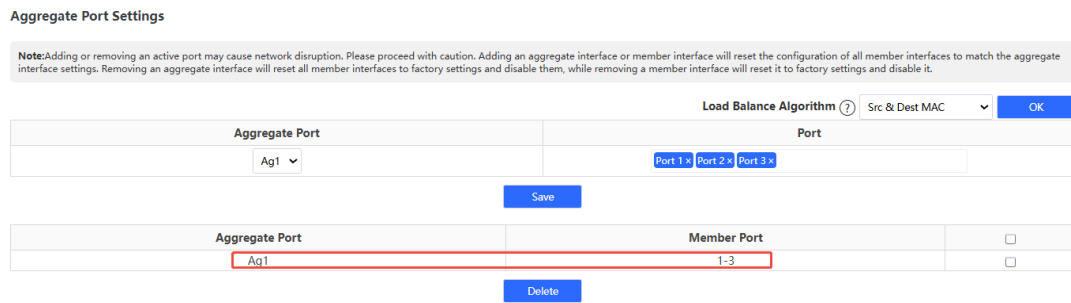

Figure 3-10 Secondary Confirmation for Modifying Member Ports



- (4) Wait until the member ports of the aggregate interface are updated in the list below.

Figure 3-11 Succeeded in Modifying Member Ports of an Aggregate Interface



3. Deleting an Aggregate Interface

Select one or two aggregate interfaces to be deleted and click **Delete**. Read the message displayed on the pop-up window and click **OK** to confirm deletion.

Caution

- Exercise caution when deleting a running member port, as this operation may cause network interruption.
- When you delete an aggregate interface, its member ports are reset to factory settings and disabled.

Figure 3-12 Deleting an Aggregate Interface

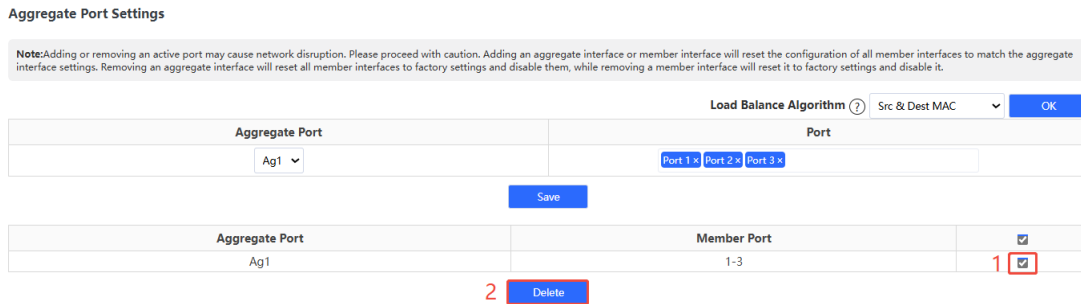

3.3.3 Configuring Load Balancing Algorithms

Choose **Configuration > Port Aggregation**.

Click **Load Balance Algorithm** in the upper right corner, select a load balancing algorithm from the drop-down list, and click **OK**. The device will distribute incoming packets of all aggregate interfaces according to the specified load balancing algorithm.

Caution

The load balancing algorithm takes effect globally. After configuration, it takes effect on all aggregate interfaces of the device.

Figure 3-13 Configuring a Load Balancing Algorithm for All Aggregate Interfaces

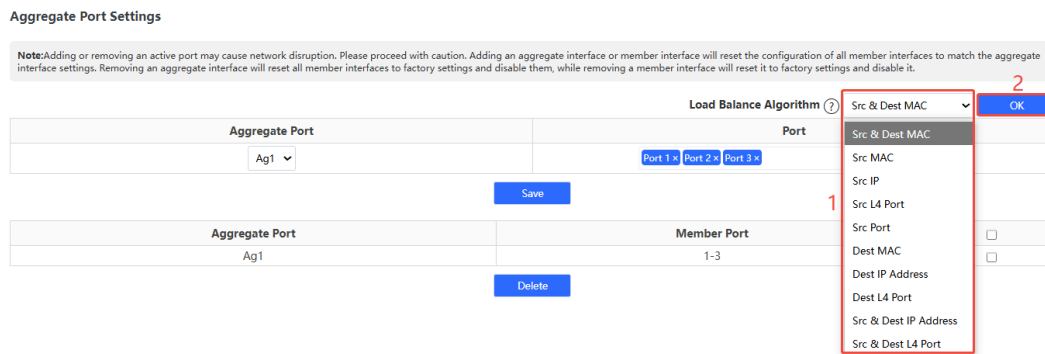

3.4 Port Mirroring

3.4.1 Overview

In network monitoring and troubleshooting scenarios, users need to analyze data traffic on suspicious network nodes or device ports. When port mirroring is enabled, packets received and transmitted on the source port will be mirrored to the mirror port (destination port). You can monitor and analyze the packets on the mirror port through network analyzer without affecting the normal data forwarding of the monitored device.

As [Figure 3-14](#) shows, by configuring port mirroring on Device A, the packets on Port 1 are mirrored to Port 10. Though the network analyzer is not directly connected to Port 1, it can receive all packets on Port 1 and is able to monitor the data traffic on Port 1.

Figure 3-14 Operating Principle of Port Mirroring



3.4.2 Configuration Steps

Choose **Configuration > Port Mirroring**.

Select the source port, the monitoring direction, and the mirror port, and click **Save**. The device supports configuring one port mirroring rule.

If you want to delete port mirroring configuration, click **Delete**.

Caution

- You can select multiple source ports but only one mirror port. The source ports cannot contain the mirror port.
- Only one port mirroring rule can be configured. If multiple rules are configured, the latest configuration takes effect.

Figure 3-15 Configuring Port Mirroring

Port Mirroring

Packets received and transmitted on the source port will be mirrored to the mirror port.

Source Port Member	Direction	Mirror Port
--Select--	Input	Port 1

Source Port Member	Direction	Mirror Port
1	Input	2

Table 3-3 Port Mirroring Parameters

Parameter	Description
Source Port Member	The source port is also called the monitored port. Packets on the source port will be mirrored to the mirror port for network analysis or troubleshooting. You can select multiple source ports. Packets on these ports will be mirrored to one mirror port.
Direction	Direction of the data traffic monitored on the source port: <ul style="list-style-type: none"> ● Bi-directions (input & output): All packets on the source port, including the received packets and the transmitted packets, will be mirrored to the mirror port. ● Input: The packets received by the source port will be mirrored to the mirror port. ● Output: The packets transmitted from the sourced port will be mirrored to the mirror port.
Mirror Port	The mirror port is also called the monitoring port. The mirror port is connected with a monitoring device, and it transmits packets on the source port to the monitoring device.

3.5 Port Isolation

Choose **Configuration > Port Isolation**.

Port isolation is used for isolating layer-2 packets. When port isolation is enabled, the downlink ports are isolated from each other but can communicate with uplink ports.

Port isolation is disabled by default. Toggle the switch to **On** to enable port isolation.

Figure 3-16 Port Isolation

Port Isolation

Downlink ports (1-8) will be isolated. The last 2 ports (9-10) are uplink ports and will not be isolated. (Packets will be forwarded between the uplink port and the downlink port. Downlink ports are not allowed to forward packets to each other).

Status

Note

The number of the uplink/downlink ports and port IDs of different devices vary. Please refer to the specific device's documentation for accurate information.

3.6 Port-based Rate Limiting

Choose **QoS > Rate Limiting**.

You can configure rate limiting rules for packets in the input direction and the output direction of ports. There is no rate limiting on ports by default.

Select the port you want to configure, then select the rate limiting type and status, and enter the rate limit. Click **Save** to save the configuration. The configuration will be displayed accordingly in the **Port Rate** table right below the **Save** button.

Figure 3-17 Port Rate Limiting

Rate Limiting

Port	Type	Status	Rate(Mbit/sec)
--Select--	Input	Disabled	No Limit (1-1000M)

Save

Port	Input Rate(Mbit/sec)	Output Rate(Mbit/sec)
Port 1	No Limit	No Limit
Port 2	No Limit	No Limit
Port 3	No Limit	No Limit
Port 4	No Limit	No Limit
Port 5	No Limit	No Limit
Port 6	No Limit	No Limit
Port 7	No Limit	No Limit
Port 8	No Limit	No Limit
Port 9	No Limit	No Limit
Port 10	No Limit	No Limit

Table 3-4 Rate Limiting Parameters

Parameter	Description	Default
Port	You can select multiple ports for rate limiting configuration in batches.	No default value
Type	The direction of the rate-limited data traffic: <ul style="list-style-type: none"> ● Input & output: Rate limiting for all packets forwarded over the port, including the received packets and the transmitted packets. ● Input: Rate limiting for packets received by the port. ● Output: Rate limiting for packets transmitted from the port. 	No default value
Status	You can decide whether to enable or disable rate limiting.	Disabled
Rate (Mbit/sec)	The maximum rate at which packets are forwarded over the port.	No Limit

Note

The port rate limit range varies with the switch model.

3.7 Management IP Address

Choose **Configuration > IP Settings**.

You can configure the management IP address of the device. By accessing the management IP address, you can configure and manage the device.

- There are two methods for obtaining IP addresses:
 - Dynamic IP address: Enable **Auto Obtain IP** to use the IP address assigned dynamically by the uplink DHCP server.

If you enable **Auto Obtain IP**, the device automatically obtains various parameters from the DHCP server. You can select whether to obtain the DNS address from the DHCP server. If you disable **Auto Obtain DNS**, you need to manually set the DNS server address.
 - Static IP address: Disable **Auto Obtain IP** to use the fixed IP address configured manually by the user. If **Auto Obtain IP** is disabled, you need to manually enter the IP address, subnet mask, gateway IP address, and DNS server address. Click **Save** to enforce the configuration.
- **VLAN** is used for managing VLAN tag of the management packets. If VLAN settings are disabled, the management packets will be untagged, and management VLAN configuration is not supported. The management VLAN of the device is VLAN 1 by default.

Figure 3-18 IP Settings

IP Settings

VLAN	VLAN 1
Auto Obtain IP	Enabled
	<small>If you disable this feature, multi-DHCP alarming will fail.</small>
IP Address	192.168.110.61
Submask	255.255.255.0
Gateway	192.168.110.1
Auto Obtain DNS	Enabled
DNS	192.168.110.1

[Save](#)

Note

- Disable VLAN settings, and the management packets will be untagged. If you want to tag packets, please enable VLAN settings. For details, see [4.2.1 Global VLAN Settings](#).
- The management VLAN must be selected from the existing VLANs. To create a static VLAN, refer to [4.2.2 Static VLANs Settings](#).
- You are advised to bind a configured management VLAN to an uplink port. Otherwise, you may fail to access the web interface. For details, see [4.2.3 Port VLAN Settings](#).
- If you disable **Auto Obtain IP** feature, multi-DHCP alarming will fail. For details about multi-DHCP alarming, see [10.2 Multi-DHCP Alarming](#).

4 Switch Settings

4.1 Managing MAC Address

4.1.1 Overview

The MAC address table records mappings of MAC addresses and ports to VLANs.

The device queries the MAC address table based on the destination MAC address in a received packet. If the device finds an entry that is consistent with the destination MAC address in the packet, the device forwards the packet through the port specified by the entry in unicast mode. If the device does not find such an entry, it forwards the packet through all ports other than the receiving port in broadcast mode.

MAC address entries are classified into the following types:

- **Static MAC** address entries: Static MAC address entries are manually configured by the users. Packets whose destination MAC address matches the one in such an entry are forwarded through the corresponding port.
- **Dynamic MAC address entries:** Dynamic MAC address entries are learned dynamically by the device. They are generated automatically by the device.

4.1.2 Viewing MAC Address Table

Choose **Configuration > MAC List**.

This page displays the MAC address of the device, including the static MAC address configured manually by the users and the dynamic MAC address learned automatically by the device.

Click **Clear Dynamic MAC** to clear the dynamic MAC address learned by the device. The device will re-learn the MAC address and generate a MAC address table.

Figure 4-1 MAC Address Table

MAC List

Up to 8k MAC addresses can be learned by the device, with 2 MAC addresses already learned.
The **MAC List** displays up to 100 learned MAC addresses. Other learned MAC addresses are not shown but can be searched in **MAC Search**.

No.	MAC Address	VLAN ID	Type	Port
1	28:D0:F5:E2:DD:AF	1	Dynamic	1
2	70:42:D3:9A:3B:A0	1	Dynamic	1

[Clear Dynamic MAC](#)

Note

- If you disable VLAN, the device will forward packets according to only the destination MAC address. VLAN ID is not displayed in the MAC address table.
- Up to 100 MAC addresses are displayed.

4.1.3 Searching for MAC Address

Choose **Configuration > MAC Search**.

You can search for MAC address entries according to MAC address and VLAN ID.

Caution

If you disable VLAN, the VLAN ID will not be recorded in the MAC address table. MAC address entries can only be found through MAC address.

Enter MAC address and VLAN ID, and then click **Search**. The MAC address entries that meet the search criteria will be displayed in table right below the **Search** button. Moreover, you can enter partial characters of the MAC address for fuzzy search.

Figure 4-2 Searching for MAC Addresses (with VLAN Enabled)

MAC Search

MAC Address		VLAN ID	
00:00:00:00:00:00		VLAN ID (1-4094)	
Search			
MAC Address	VLAN ID	Type	Port
00:D0:F8:94:11:23	1	Dynamic	Port 1

Figure 4-3 Searching for MAC Addresses (with VLAN Disabled)

MAC Search

MAC Address		
00:00:00:00:00:00		
Search		
MAC Address	Type	Port
00:D0:F8:94:11:23	Dynamic	Port 1

4.1.4 Configuring Static MAC Address

Choose **Configuration > Static MAC**.

By configuring a static MAC address, you can manually bind the MAC address of a downlink network device with a port of the switch. After you add a static MAC address, when the device receives a packet destined to this address from VLAN, it forwards the packet to the specified port.

Caution

If you disable VLAN, the VLAN ID will not be recorded in the MAC address table. It is not allowed to configure a VLAN to which the static MAC address belongs.

Enter a MAC address, specify a VLAN ID and select the outbound port. Then click **Add** to add a static MAC address. The MAC address entries will be updated accordingly in the MAC address table.

Figure 4-4 Configuring Static MAC Address

Static MAC

Up to 16 MAC addresses can be configured.

MAC Address	VLAN ID	Port
<input type="text" value="0000:00:00:00:00"/>	<input type="text" value="VLAN ID (1-4094)"/>	<input type="text" value="Port 1"/>

[Add](#)

No.	MAC Address	VLAN ID	Port
<input type="checkbox"/>	1	00:74:9C:71:74:FF	2
<input type="checkbox"/>			Port 4

[Delete](#)

If you want to delete a static MAC address, select the MAC address entry you want to delete in the table and click **Delete**.

4.2 VLAN Settings

4.2.1 Global VLAN Settings

Choose **Home** from the navigation page.

This page displays the status of VLAN settings. You can toggle on or off **VLAN Settings**.

- When VLAN is disabled, the device operates like an un-managed switch. The device forwards packets according to the destination MAC address, and the VLAN information of the forwarding packets remains unchanged during the forwarding process.
- When VLAN is enabled, the device operates like a managed switch. The device forwards packets according to the destination MAC address and VLAN ID. You can configure the port mode (access or trunk) based on whether a VLAN tag is carried in packets. Besides, all device ports will be initialized to access ports.

Figure 4-5 VLAN Settings

Device Info

Model:	RG-
MAC Address:	10:8
IP Address:	192.168.110.24
Cloud Status:	Connected Download App

Port Info VLAN Settings ?

Port	Status	Config Status		Actual Status	Flow Control(Config)	Flow Control(Actual)
		Speed	Duplex			
		Port 1	Enabled			
Port 2	Disabled	Auto	Auto	Disconnected	Disabled	Disabled
Port 3	Disabled	Auto	Auto	Disconnected	Disabled	Disabled
Port 4	Disabled	Auto	Auto	Disconnected	Disabled	Disabled

Note

Apart from choosing **Home** from the navigation page, you can also choose **VLAN > VLAN List** or **VLAN > VLAN Settings** to toggle on or off **VLAN Settings**. Configuration through three paths has the same effects and takes effect instantly for all the paths.

4.2.2 Static VLANs Settings

Choose **VLAN > VLAN List**.

Enter VLAN ID and click **Add** to create a static VLAN.

Note

- You can create static VLANs only when **VLAN Settings** is toggled on.
- The VLAN ID ranges from 1 to 4094. VLAN 1 is the default VLAN.
- The maximum number of static VLANs that can be created varies with the device model. Please refer to the maximum number shown on the configuration page.
- The Management VLAN (VLAN 1), Native VLAN, Permit VLAN, and Access VLAN cannot be deleted.

The VLAN table contains the existing VLANs. Select the VLANs and click **Delete**, and the corresponding VLANs will be deleted. VLAN 1 cannot be deleted.

Figure 4-6 Static VLANs Settings

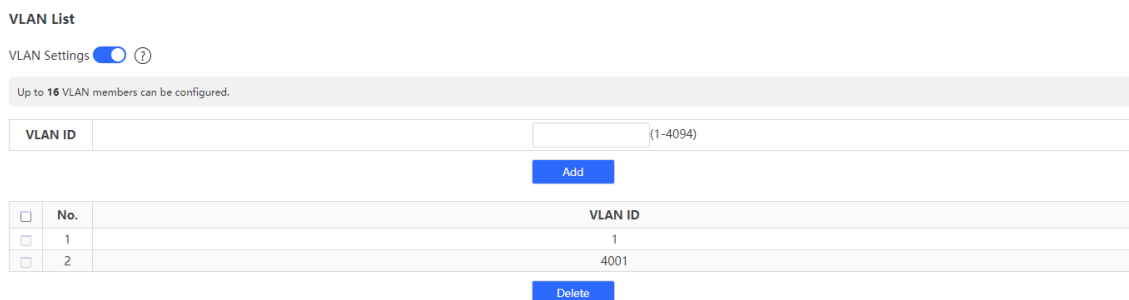

4.2.3 Port VLAN Settings

Caution

Improper configuration of VLANs on a port (especially uplink port) may cause the failure to log in to eWeb. Therefore, exercise caution when configuring VLANs.

Choose **VLAN > VLAN Settings**.

Configure the port mode and VLAN members of a port, and you will know the allowed VLANs of the port and whether the packets forwarded by the port carry tags.

- (1) Select the target ports. Multiple ports can be selected.
- (2) Configure the port type.
 - Access: If the port is an access port, select **Access** for the port.

- o Trunk: If the port is a trunk port, select a native VLAN for the port, and enter the VLAN ID range of permit VLANs.

(3) Click **Save**.

The configured port information is synchronized to the table on the **VLAN Settings** page.

Note

- You are advised to create VLAN members (refer to [4.2.2 Static VLANs Settings](#)) before configuring the port based on VLANs. Click **VLAN List** to access the **VLAN List** page where you can add VLAN members.
- You can configure VLANs on ports only when **VLAN Settings** is toggled on.
- VLAN configuration is disabled on the RG-ES series switches by default.

Figure 4-7 Configuring Port VLANs

VLAN Settings

VLAN Settings ?

You can go to [VLAN List](#) to add a VLAN ID.

Port	Port Mode	Access VLAN <small>The packets of this VLAN are untagged.</small>	Native VLAN <small>The packets of this VLAN are untagged.</small>	Permit VLAN
Port 1	Trunk	VLAN 1	VLAN 1	--Select--

Save

Port	Port Mode	Access VLAN	Native VLAN	Permit VLAN
Port 1	Access	1	--	--
Port 2	Access	1	--	--
Port 3	Access	1	--	--
Port 4	Access	1	--	--
Port 5	Access	1	--	--
Port 6	Access	1	--	--
Port 7	Access	1	--	--
Port 8	Access	1	--	--
Port 9	Trunk	--	1	1,4001
Port 10	Trunk	--	1	1,4001

Table 4-1 Port Modes

Port Mode	Description
Access	<ul style="list-style-type: none"> ● One access port can belong to only one VLAN and allow frames from this VLAN only to pass through. This VLAN is called an access VLAN. ● The frames from the access port do not carry VLAN tag. When the access port receives an untagged frame from a peer device, the local device determines that the frame comes from the access VLAN and adds the access VLAN ID to the frame. ● Access port is connected to the endpoints.
Trunk	<ul style="list-style-type: none"> ● One trunk port supports one Native VLAN and several Permit VLANs. Native VLAN frames forwarded by a trunk port do not carry tags while Permit VLAN frames forwarded by the trunk port carry tags. Trunk port is connected to switches. ● You can set the Permit VLAN range to limit VLAN frames that can be forwarded. ● Make sure the trunk ports at the two ends of the link are configured with the same Native VLAN.

5 Security

5.1 DHCP Snooping

5.1.1 Overview

The Dynamic Host Configuration Protocol (DHCP) snooping function allows a device to snoop DHCP packets exchanged between clients and a server to record and monitor the IP address usage and filter out invalid DHCP packets, including request packets from the clients and response packets from the server.

5.1.2 Configuration Steps

Choose **Configuration > DHCP Snooping**.

Toggle the switch to **On** to enable DHCP snooping, select the trusted ports, and then click **Save**.

When DHCP snooping is enabled, response packets are forwarded from only trusted ports of the DHCP servers.

Caution

The uplink port connected to the DHCP server is configured as the trusted port generally.

Figure 5-1 DHCP Snooping

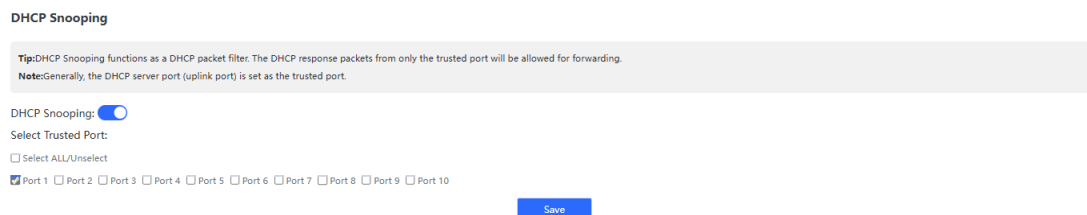

5.2 Storm Control

5.2.1 Overview

When a local area network (LAN) has excess broadcast, multicast, or unknown unicast data flows, the network speed will slow down and packet transmission will have an increased timeout probability. This situation is called a LAN storm, which may be caused by topology protocol execution errors or incorrect network configuration.

You can perform storm control separately for the broadcast, unknown multicast, and unknown unicast data flows. When the rate of broadcast, unknown multicast, or unknown unicast data flows received over a device port exceeds the specified range, the device transmits only packets in the specified range and discards packets beyond the range until the packet rate falls within the range. This prevents flooded data from entering the LAN and causing a storm.

5.2.2 Configuration Steps

Choose **QoS > Storm Control**.

Select the storm control type, port, status, and enter the rate limit, and then click **Save**.

Figure 5-2 shows the storm control types and corresponding rates on device ports.

- When storm control is enabled, the corresponding rate limits will be displayed.
- When storm control is disabled, the rate of broadcast, unknown multicast, and unknown unicast data flows is not limited. The corresponding status is displayed **Disabled**.

Figure 5-2 Storm Control

Storm Control

Type	Port	Status	Rate(Mbit/sec)
Broadcast	--Select--	Disabl	No Limit (1-1000M)

Type	Broadcast(Mbit/sec)	Unknown Unicast(Mbit/sec)	Unknown Multicast(Mbit/sec)
Port 1	Disabled	Disabled	Disabled
Port 2	Disabled	Disabled	Disabled
Port 3	Disabled	Disabled	Disabled
Port 4	Disabled	Disabled	Disabled
Port 5	Disabled	Disabled	Disabled
Port 6	Disabled	Disabled	Disabled
Port 7	Disabled	Disabled	Disabled
Port 8	Disabled	Disabled	Disabled
Port 9	Disabled	Disabled	Disabled
Port 10	Disabled	Disabled	Disabled

5.3 Loop Guard

Choose **Monitoring > Loop Prevention**.

When loop guard feature is enabled, the port causing the loop will be shut down automatically. After the loop is removed, the port will be up automatically. The loop guard feature is enabled by default.

Figure 5-3 Loop Prevention

Loop Prevention

The port causing the loop will be shut down. After the loop is removed, the port will be up automatically.

Enabled	<input checked="" type="checkbox"/>
---------	-------------------------------------

6 PoE Settings

✓ Specification

- In [Table 1-1](#), switch models with the suffixes -P, -LP, or -HP, such as RG-ES207GS-P, support PoE.
- The RG-ES207GS-AC-OD and RG-ES207GS-PI-OD also support PoE.

6.1 PoE Information

The devices supply power to powered devices (PDs) through PoE ports. On the PoE Info page, you can view the total power, used power, remaining power, and current work status of the PoE system.

PoE Info



6.2 PoE Settings

6.2.1 PoE In Settings

The RG-ES207GS-PI-OD can be powered through a DC power cord or through port 5 from an uplink Power Sourcing Equipment (PSE) using an Ethernet cable.

- When the switch is powered only by DC and port 5 is not connected to a PSE, the PoE function of the switch is unavailable. The following notification is displayed on the web interface, as shown in [Figure 6-1](#).

Figure 6-1 Figure 1-1 PoE Unavailable Notification

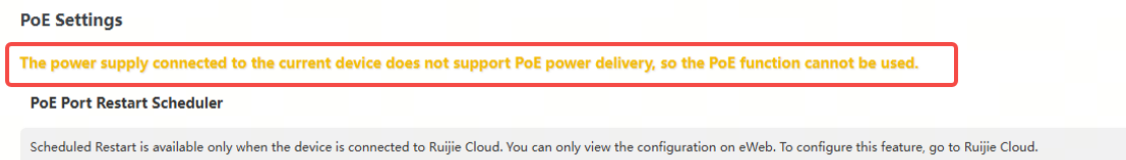

- When the switch is powered by both DC power and PoE input, PoE input takes precedence over DC power.
- When the RG-ES207GS-PI-OD is powered by PoE input, its PoE output capability (PoE budget) depends on the PoE input power. For details, see [Table 6-1](#).

Table 6-1 Relationship Between PoE Input Power and PoE Budget

PoE Input Power	PoE Budget
90 W (PoE++)	60 W
60 W (PoE++)	40 W
30 W (PoE+)	19 W
15.4 W (PoE)	6 W

< 15.4 W	The RG-ES207GS-PI-OD continuously attempts to supply power to the downlink PDs, but fails to do so properly.
----------	--

6.2.2 PoE watchdog

PoE watchdog: This feature is mainly applicable to Closed-Circuit Television (CCTV) scenarios for security purposes. After this feature is enabled, when a PoE port of the device suddenly stops receiving packets during the ping interval, the powered device (PD) will be restarted after the ping interval expires to restore normal operation.

Note

If a non-PD, such as a PC, is connected to a PoE port of this device, the PoE watchdog will not initiate any action on the non-PD even if the trigger condition is met.

Table 6-2 PoE Watchdog Application Description

Packet Receiving Status of the PoE Port	Whether PoE Watchdog is Enabled	Action Taken on the PD
During the ping interval, a PoE port of the device suddenly stops receiving packets.	Yes	Restart the PD to restore normal operation and reset the ping interval.
	No	No action is initiated on the PD.
During the ping interval, a PoE port of the device stops receiving packets all the time.	Yes	No action is initiated on the PD.
	No	No action is initiated on the PD.
During the ping interval, a PoE port of the device starts to receive packets.	Yes	Reset the ping interval.
	No	No action is initiated on the PD.

6.2.3 PoE Port Restart Scheduler

The **PoE Port Restart Scheduler** feature allows the network administrator to configure a scheduled restart plan for one or more PoE ports on Ruijie Cloud or Ruijie Reeye App. The system automatically cuts off and restores PoE power supply to specified ports according to the preset time (accurate to minutes, range: 00:00 to 23:59), thereby restarting downlink PDs remotely and automatically to restore their optimal operation.

Note

- Only one scheduled restart policy can be configured.
- You can configure this feature only on Ruijie Cloud or Ruijie Reeye App. The eWeb interface only allows you to view the configuration status.

Figure 6-2 PoE Port Restart Scheduler Is Not Configured

PoE Settings

PoE Port Restart Scheduler No config

Scheduled Restart is available only when the device is connected to Ruijie Cloud. You can only view the configuration on eWeb. To configure this feature, go to Ruijie Cloud.

6.2.4 Perpetual PoE

The **Perpetual PoE** feature ensures that the switch supplies uninterrupted power to connected PDs during a switch restart (for example, during a firmware upgrade). This feature is enabled by default.

Port status

- The voltage, current, output power, and current power status of the device ports are displayed.
- You can toggle on or off PoE Status to enable or disable the PoE feature. When PoE is disabled, the port will not supply power to PDs.
- When the switch needs to supply power to a PD that does not comply with IEEE 802.3af/at, you can toggle on Non-Standard.

PoE Info

Total Power 130w	Used 0w	Remaining 130w	Work Status Normal
----------------------------	-------------------	--------------------------	------------------------------

PoE Settings

PoE watchdog

Click Save for the new interval to take effect.

Ping Interval Range:90-1800

PoE Status <small>When off, PoE will not work on this port</small>	Port	Power(W)	Current(mA)	Voltage(V)	Non-Standard <small>PoE Non-standard PoE: When enabled, the device can supply power to a PD that may not conform to IEEE802.3af/at standards.</small>	Power Status	Action
<input checked="" type="checkbox"/>	Port 1	0	0	0	<input type="checkbox"/>	Off	--
<input checked="" type="checkbox"/>	Port 2	0	0	0	<input type="checkbox"/>	Off	--
<input checked="" type="checkbox"/>	Port 3	0	0	0	<input type="checkbox"/>	Off	--
<input checked="" type="checkbox"/>	Port 4	0	0	0	<input type="checkbox"/>	Off	--
<input checked="" type="checkbox"/>	Port 5	0	0	0	<input type="checkbox"/>	Off	--
<input checked="" type="checkbox"/>	Port 6	0	0	0	<input type="checkbox"/>	Off	--
<input checked="" type="checkbox"/>	Port 7	0	0	0	<input type="checkbox"/>	Off	--
<input checked="" type="checkbox"/>	Port 8	0	0	0	<input type="checkbox"/>	Off	--
<input checked="" type="checkbox"/>	Port 9	0	0	0	<input type="checkbox"/>	Off	--

7 ERPS

✔ Specification

This feature is supported only on optical ports of switches, such as RG-ES207GS-AC-OD, RG-ES207GS-PI-OD, RG-ES216GC2MS, RG-ES224GC2MS, RG-ES220GS-P-V2, and RG-ES228GS-P-V2.

7.1 Overview

Ethernet Ring Protection Switching (ERPS), also known as G.8032, is a ring protection protocol developed by the International Telecommunication Union (ITU). It is a data link layer protocol specially designed for Ethernet rings. ERPS prevents broadcast storms caused by data loops when an Ethernet ring network is intact, and can rapidly perform link switching and recover the communication between nodes when a link is disconnected in the Ethernet ring, so as to implement data link redundancy.

Currently, the Spanning Tree Protocol (STP) is another solution to the Layer 2 network loop problem. STP is at mature application stage but requires a relatively long (within seconds) convergence time. Compared with STP, ERPS provides faster convergence, with the Layer 2 convergence time less than 50 ms.

7.2 Control VLAN and Data VLAN

ERPS supports two types of virtual local area networks (VLANs): control VLANs and data VLANs.

- Control VLAN: Also known as the Ring Auto Protection Switching VLAN (R-APS VLAN) for transmitting ERPS protocol packets. On a device, the ports connecting to an ERPS ring belong to a control VLAN, and only such ports can be added to a control VLAN.
- Data VLAN: A data VLAN is used to transmit data packets. Both ERPS ports and non-ERPS ports can be assigned to a data VLAN. A data VLAN is also known as a protected VLAN.

7.3 Basic Model of an Ethernet Ring

A group of interconnected devices in the same control VLAN (R-APS VLAN) constitute an Ethernet ring (ERPS ring), in which each device is called a node. ERPS rings can be classified into major rings and subrings based on whether a ring is closed.

7.3.1 Major Ring and Subring

- Major ring and major ring link: A major ring is a topology of a closed network connected in a ring, such as the blue rings shown in [Figure 7-1](#). In an ERPS ring, links that belong to and are controlled by a major ring are called major ring links.
- Subring and subring link: A subring is a topology of a non-closed network attached to a major ring, such as the green ring shown in [Figure 7-1](#). In an ERPS ring, links that belong to and are controlled by a subring are called subring links.
- R-APS virtual channel of a subring: As shown in [Figure 7-1](#), all the links on the major ring can be regarded as R-APS virtual channels of subrings, which are used to forward subring protocol packets. They belong to

the major ring instead of the subring. The major ring must associate with the control VLAN of the subring and allow packets from this VLAN to pass through.

Figure 7-1 Basic Topologies of Ethernet Rings

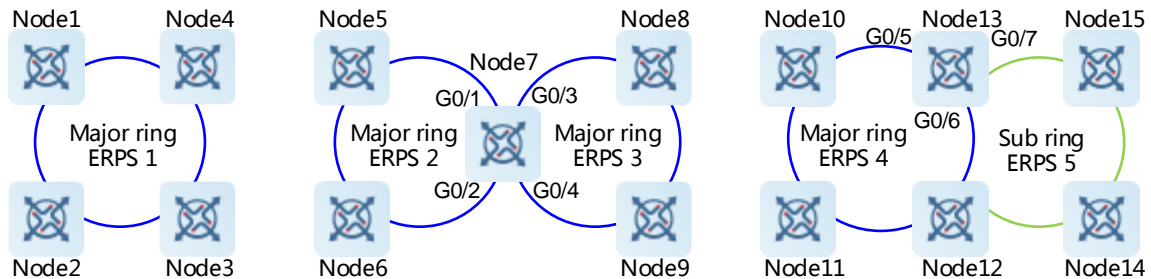

7.3.2 Basic Topologies

Major rings, subrings, and nodes can form basic topologies with different characteristics, depending on the connection modes, as shown in [Figure 7-1](#).

- Single ring: Major ring ERPS 1 (node 1-2-3-4) constitutes a single-ring topology.
- Tangent rings: A topology in which two ERPS rings share one device is called tangent rings. Major ring ERPS 2 (node 5-6-7) and major ring ERPS 3 (node 7-8-9) constitute a tangent-ring topology, and are tangent to each other on one node, namely, node 7.
- Intersecting rings: A topology in which two ERPS rings share two devices is called intersecting rings. Major ring ERPS 4 (node 13-10-11-12) and subring ERPS 5 (node 13-15-14-12) constitute an intersecting-ring topology, and intersect on two directly connected intersecting nodes, namely, node 13 and node 12.
- In practice, a network is a combination of multiple basic topologies, with multiple major rings and multiple subrings.

7.3.3 Node

According to the different topological relationships between nodes and Ethernet rings, nodes are classified into single-ring nodes, tangent nodes, and intersecting nodes by role.

- Single-ring node: In an Ethernet ring, the nodes that belong to only one Ethernet ring (either major ring or subring) are called single-ring nodes. Two interfaces need to be provided on a single-ring node so that the node can be added to one ERPS ring. As shown in [Figure 7-1](#), nodes 1-4 in the single-ring topology, nodes 5, 6, 8, and 9 in the tangent-ring topology, and nodes 10, 11, 14, and 15 in the intersecting-ring topology are all single-ring nodes.
- Tangent node: A device shared in tangent rings is called a tangent node. Four interfaces need to be provided on each tangent node, with two added to a major ring and the other two added to another major ring. As shown in [Figure 7-1](#), node 7 in the tangent-ring topology is a tangent node.
- Intersecting node: The nodes in intersecting rings that belong to multiple rings are called intersecting nodes. Three interfaces need to be provided on a tangent node, with two added to a major ring and the other added to a subring. As shown in [Figure 7-1](#), nodes 12 and 13 in the intersecting-ring topology are intersecting nodes. ERPS rings can intersect with other multiple ERPS rings and share links to implement data link redundancy. Services can be quickly switched from a failed link in one ERPS ring to a normal link.

7.3.4 Ring Member Port

An Ethernet ring has two ring member ports on each node that it passes through: the **west** and **east** ports. As shown in [Figure 7-1](#):

- If an ERPS ring is a closed major ring, each node that the ring passes through has two interfaces used as the **west** and **east** ports for adding the node to the ERPS ring. For example, on node 7, GigabitEthernet 0/1 and 0/2 are added to the major ring ERPS 2, and GigabitEthernet 0/3 and 0/4 are added to the major ring ERPS 3. On node 13, GigabitEthernet 0/5 and 0/6 are added to the major ring ERPS 4.
- If an ERPS ring is a non-closed subring (in an intersecting-ring topology), a non-intersecting node has two interfaces used as the **west** and **east** ports for adding the node to the ERPS subring, such as node 15. On an intersecting node, only one physical port is added to the ERPS subring as a ring member port, and the other ring member port is a virtual channel (indicated by **virtual-channel**). For example, on node 13, only GigabitEthernet 0/7 is added to the subring ERPS 5.

There are two states for a port running the ERPS protocol: forwarding and block. Their functions are listed in [Table 7-1](#).

Table 7-1 ERPS Protocol Port States

Port State	Receiving Protocol Packets	Sending Protocol Packets	Address Learning	Receiving Data Packets	Sending Data Packets
Block	Yes	Yes	No	No	No
Forwarding	Yes	Yes	Yes	Yes	Yes

7.4 RPL and Nodes

An Ethernet ring can be in either of the following two states regardless of whether it is a major ring or subring:

- **Idle** state: The physical links in the entire ring network are connected.
- **Protection** state: A physical link in the ring network is disconnected.

Ring protection link (RPL): When the physical links in a ring network are connected, the ERPS ring is in the idle state, and the links in the logic blocking state are RPLs. Each Ethernet ring has only one RPL. For example, the links indicated by the orange lines shown in [Figure 7-2](#) are RPLs, the link between node 3 and node 4 is the RPL of the Ethernet ring ERPS 1 (node 1-2-3-4), and the link between node 5 and node 6 is the RPL of the Ethernet ring ERPS 2 (node 3-5-6).

A node that is adjacent to an RPL and is used to block the RPL to prevent loops when the Ethernet ring is free of faults is called an RPL **owner** node. As shown in [Figure 7-2](#), node 4 is the RPL owner node of the Ethernet ring ERPS 1 (node 1-2-3-4) and node 6 is the RPL owner node of the ERPS 2 (node 3-5-6).

Any nodes other than the RPL owner node in an Ethernet ring are non-RPL owner nodes. As shown in [Figure 7-2](#), nodes except node 4 and node 6 are non-RPL owner nodes of the rings.

Blocked ports on RPLs are RPL ports, and RPL ports do not forward data packets to prevent loops. RPL ports are on RPL owner nodes, and the RPL owner nodes block the RPL ports. Each Ethernet ring has only one RPL owner node.

Figure 7-2 Typical Topology of Tangent Rings

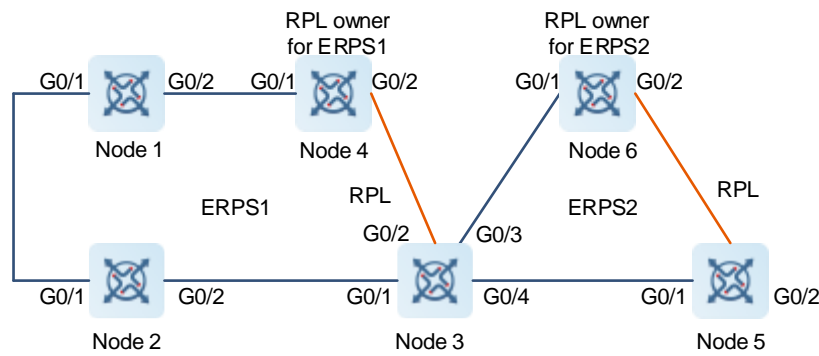

As shown in [Figure 7-2](#), the link between node 3 and node 4 is the RPL of the Ethernet ring ERPS 1. As the RPL owner node of ERPS 1, node 4 blocks the RPL port. The link between node 5 and node 6 is the RPL of the Ethernet ring ERPS 2. As the RPL owner node of ERPS 2, node 6 blocks the RPL port. ERPS 1 (node 1-2-3-4) and ERPS 2 (node 3-5-6) share node 3, forming a tangent-ring topology. Node 3 is the tangent node.

Figure 7-3 Typical Topology of Intersecting Rings

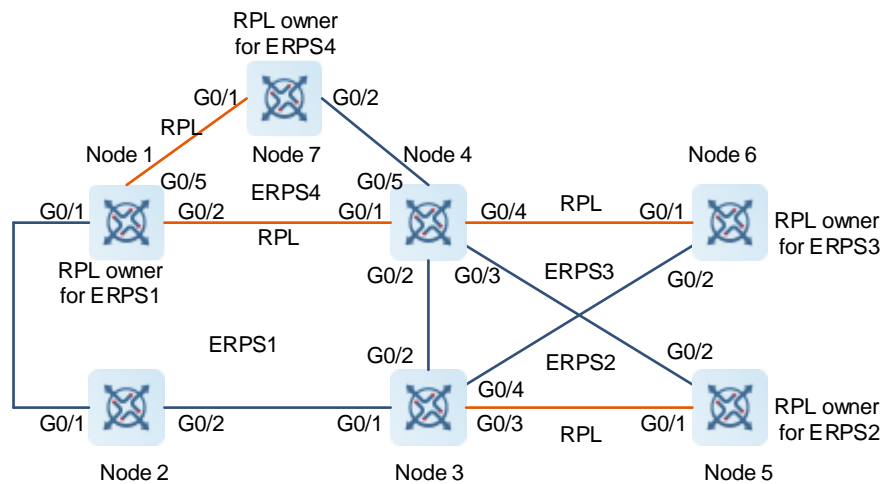

As shown in [Figure 7-3](#), ERPS 1 (node 1-2-3-4) is a major ring, and ERPS 2 (node 3-4-5) is a subring. ERPS 1 and ERPS 2 share node 3 and node 4, forming an intersecting-ring topology. The links between node 4 and node 5, and between node 3 and node 5 are links of the subring ERPS 2 and are controlled by ERPS 2. The link between node 3 and node 4 belongs to the major ring not the subring, and is not controlled by the subring. However, the protocol packets of the subring are transmitted through the direct link between node 3 and node 4. This direct link is the R-APS virtual channel of the subring ERPS 2. Node 2 only belongs to the major ring ERPS 1, and is called a single-ring node. Node 6 only belongs to the subring ERPS 3, and is also called a single-ring node. Node 3 and node 4 are tangent nodes.

7.5 ERPS Packet

ERPS packets (also called R-APS packets) are classified into Signal Fail (SF) packets, No Request (NR) packets, No Requests-RPL Blocked (NR-RB) packets, and Flush packets.

- SF packet: When the link of a node is down, the node sends an SF packet to notify other nodes of its link failure.
- NR packet: When the failed link is restored, the node sends an NR packet to notify the RPL owner node of its link recovery.
- NR-RB packet: When all nodes in an ERPS ring function properly, the RPL owner node sends NR-RB packets periodically.
- Flush packet: In intersecting rings, when a topology change occurs in a subring, the intersecting nodes send flush packets to notify other devices in the Ethernet ring to which the subring is connected.

7.6 ERPS Timer

ERPS supports three timers: Holdoff timer, Guard timer, and **Wait-To-Restore** (WTR) timer.

- **Holdoff** timer: The timer is used to minimize frequent ERPS topology switching due to intermittent link failures. After you configure the Holdoff timer, ERPS performs topology switching only if the link failure still persists after the timer times out.
- **Guard** timer: The timer is used to prevent a device from receiving expired R-APS PMDU packets. When a device detects that a link failure is cleared, it sends link recovery packets and starts the **Guard** timer. Before the timer expires, all packets except Flush packets indicating a subring topology change will be discarded.
- **WTR timer**: The timer is effective only for RPL owner nodes. It is used to avoid ring status misjudgment by the RPL owner node. When an RPL owner node detects that a failure is cleared, it will not perform topology switching immediately but only if the Ethernet ring is recovered after the WTR timer times out. If a ring failure is detected again before the timer expires, the RPL owner node cancels the timer and does not perform topology switching.

7.7 Ring Protection

The ring protection function prevents broadcast storms caused by data loops and can rapidly recover the communication between nodes when a link is disconnected in the Ethernet ring.

- Normal state
 - All nodes in the physical topology are connected in ring mode.
 - ERPS blocks the RPL to prevent loops.
 - ERPS detects failures on each link between adjacent nodes.

- Link fault

A node adjacent to a failed node detects the fault.

The node adjacent to the failed link blocks the failed link and sends SF packets to notify other nodes in the same ring.

An SF packet triggers the RPL owner node to enable the RPL port, and also triggers all nodes to update their MAC address entries and ARP/ND entries and enter the protection state.

- Link recovery

When a failed link is restored, an adjacent node still blocks the link and sends NR packets indicating that no local fault exists.

When the RPL owner node receives the first NR packet, it starts the WTR timer.

When the WTR timer times out, the RPL owner node blocks the RPL and sends an NR-RB packet.

After receiving this NR-RB packet, other nodes update their MAC address entries and ARP/ND entries, and the node that sends the NR packet stops sending the NR packet and enables the blocked ports.

- The ring network is restored to the normal state.

7.8 Protocols and Standards

ITU-T G.8032/Y.1344: Ethernet ring protection switching

7.9 Configuring ERPS

7.9.1 Prerequisites

Choose **VLAN > VLAN Settings**.

Before configuring ERPS, configure all optical ports of the device as trunk ports and configure **Permit VLAN**.

VLAN Settings

VLAN Settings ?

You can go to [VLAN List](#) to add a VLAN ID.

Port	Port Mode	Access VLAN The packets of this VLAN are untagged.	Native VLAN The packets of this VLAN are untagged.	Permit VLAN
Port 27 × Port 28 ×	Trunk ▾	VLAN 1 ▾	VLAN 1 ▾	VLAN 1 × VLAN 5 × VLAN 6 ×

Save

7.9.2 Adding and Deleting an ERPS Ring

Choose **ERPS > Ring Configuration**.

Configure ring parameters based on service requirements.

Note

- After a port role is changed, remove and reconnect the cable for the port configuration to take effect.
- A maximum of one ERPS ring can be configured.

Ring Configuration

After changing the port role, unplug and plug back in the cable connected to the port for the changes to take effect. Only 1 ERPS ring can be configured.

ID	<input type="text" value=""/> (1-255)
Control VLAN	VLAN 1 ▾
West Port/Role	Port 27 ▾ NORMAL ▾
East Port/Role	Port 27 ▾ NORMAL ▾
WTR Timer(min)	5 (1-12)
Guard Timer(ms)	500 (10-2000)
Hold(ms)	0 (0-10000)
MEL Level	7(High) ▾
Revertive Mode	Enabled ▾

Add

Table 7-2 Parameters of Adding an ERPS Ring

Parameter	Description	Default Value
ID	Specifies the ID of an ERPS instance, ranging from 1 to 255.	N/A
Control VLAN	It is used to forward ERPS packets.	N/A
West Port/Role	Specifies the west port in the ERPS ring and the port role. The values of a port role include: <ul style="list-style-type: none"> ● NORMAL: Indicates a normal node. ● RPL OWNER: Indicates an RPL owner node. ● RPL NEIGHBOR: Indicates an RPL neighbor node. 	N/A
East Port/Role	Specifies the east port in the ERPS ring and the port role. The values of a port role include: <ul style="list-style-type: none"> ● NORMAL: Indicates a normal node. ● RPL OWNER: Indicates an RPL owner node. ● RPL NEIGHBOR: Indicates an RPL neighbor node. 	N/A
WTR timer(min)	Specifies the interval of the WTR timer. The duration ranges from 1 minute to 12 minutes.	Five minutes
Guard Time(ms)	Specifies the interval of the Guard timer. The duration ranges from 10 ms to 2,000 ms.	500 ms

Parameter	Description	Default Value
Hold(ms)	Specifies the interval of the Hold-off timer. The duration ranges from 0 ms to 10,000 ms. The value 0 indicates that topology switching is performed immediately after a link failure is detected.	0 ms
MEL Level	Indicates the maintenance entity group (MEG) level. The MEL level of devices in the same ERPS ring must be consistent. The value ranges from 1 to 7.	7
Revertive Mode	When it is set to Enabled and the link failure is cleared, traffic is blocked on the RPL.	Enabled

7.9.3 Link Switch

Choose **ERPS > Link Switch**.

Configure link switching parameters based on service requirements.

Link Switch

ID

12 ▾

Port

West Port ▾

Link State

Block ▾

Confirm Switch

Table 7-3 Parameter Description

Parameter	Description	Default Value
ID	Specifies the ID of an ERPS instance.	N/A
Port	Specifies the port in the ERPS ring. The values include West Port and East Port .	N/A
Link State	<p>Specifies the link state of the selected port. The values include Clear and Block.</p> <ul style="list-style-type: none"> ● Clear: Indicates that the port is elected and blocked automatically through protocol negotiation rather than by manual switching. ● Block: Indicates that the port is blocked by manual switching. 	N/A

8 Toolkit

8.1 PING

Choose **Toolkit > Ping Tool**.

The ping tool checks network connectivity. Set a destination IP address or domain name, ping count, and packet size, and click **Start** to test the network connectivity between the device and the IP address or domain name. If the prompt **Ping failed. Please check the network** is displayed, the device cannot reach the IP address or domain name.

* IP Address/Domain

✓ Supports IPv4 and domain name

* Ping Count

* Packet Size Bytes

8.2 Cloud Settings

8.2.1 Checking the Cloud Information

Choose **Toolkit > Cloud Settings**.

On this page, you can check the status of your device, including its cloud connectivity status, reason for connection failure (if the connection to Ruijie Cloud fails), the domain name and IP address of the cloud server, and whether to toggle on encryption mode (CoAPs).

Figure 8-1 Cloud Settings

Cloud Settings

Cloud Status	Connected
Domain	iotsvr001- <input type="text"/>
Encryption Mode(coaps)	<input checked="" type="checkbox"/>
IP	47.104.251.129

Security Settings

Certificate The certificate is used to verify the cloud server. Select the server certificate (.crt file) to upload.

On the **Cloud Settings** page, you can modify cloud configurations or restore the default settings.

- To change the domain name and port number of the device, enter the new domain name and port number in the **Domain** field, and then click **Save**.
- To restore the default settings, click **Restore Default**, and then click **OK** on the pop-up window to restore the domain name and encryption mode (CoAPs) to default settings. For example, when the device fails to connect to Ruijie Cloud, you can attempt to restore the connection by clicking **Restore Default**.

Table 8-1 Cloud Settings Parameters

Parameter	Description
Cloud Status	Indicates the connectivity status of the device on the cloud, including Connected , Unconnected , Connectable , and Certificate verification failure .
Reason	Indicates the reason for device connection failure. The reasons for connection failure in different cloud status are as follows: <ul style="list-style-type: none"> ● Connected: No reason is displayed. ● Unconnected: <ul style="list-style-type: none"> ○ The network connection is down or a DNS resolution error has occurred. ○ This device failed to connect to Ruijie Cloud. ● Connectable: This device is not registered to Ruijie Cloud. ● Certificate verification failure: This device failed to connect to Ruijie Cloud.
Domain	Indicates the domain name of the cloud server. <hr/> <p>Caution</p> <ul style="list-style-type: none"> ● The <code>coap://</code> prefix is not required in the domain name field as it is added by default. ● After the domain name is changed, the page is refreshed after 5 seconds by default. <hr/>
Encryption Mode(coaps)	Indicate whether the encryption mode (CoAPs) is enabled on the current device. If it is enabled, Security Settings will be displayed below. For details, see 8.2.2 Introduction to CoAP .
IP	Indicates the IP address of the cloud server resolved from the cloud address.

8.2.2 Introduction to CoAP

The Constrained Application Protocol (CoAP) is an application-layer protocol designed for compact devices and mainly used for communication in the Internet of Things (IoT) field. Thanks to the lightweight design, this protocol greatly reduces network overheads and memory usage. It is widely used in the IoT field, especially on compact, low-power, and resource-limited devices. CoAPs, the secure version of CoAP, use Datagram Transport Layer Security (DTLS) to secure data transmission.

8.2.3 Configuring CoAPs-based Encryption

After **Encryption Mode(coaps)** is toggled on, the device uses a certificate to verify the identity of a cloud server. If the verification succeeds, the device can connect to the server.

- When the device connects to a public cloud server, the device has an embedded public cloud certificate, which does not need to be imported externally.
- When the device connects to the private cloud server of RG-OCE Network Manager, you need to import the private cloud certificate for verification.

Note

Encryption Mode(coaps) can be used only in the previous two scenarios.

The configuration procedure in the two scenarios is described as follows.

1. Public Cloud

When the device is properly connected to the public cloud server, **Encryption Mode(coaps)** is enabled by default and does not need to be configured. This section describes how to disable **Encryption Mode(coaps)** and how to enable it again.

- Disable **Encryption Mode(coaps)**.
 - Toggle off Encryption Mode(coaps).
 - Change the domain name to `iotrc.ruijienetworks.com:7683` and click **Save**.

Figure 8-2 Disabling the Encryption Mode

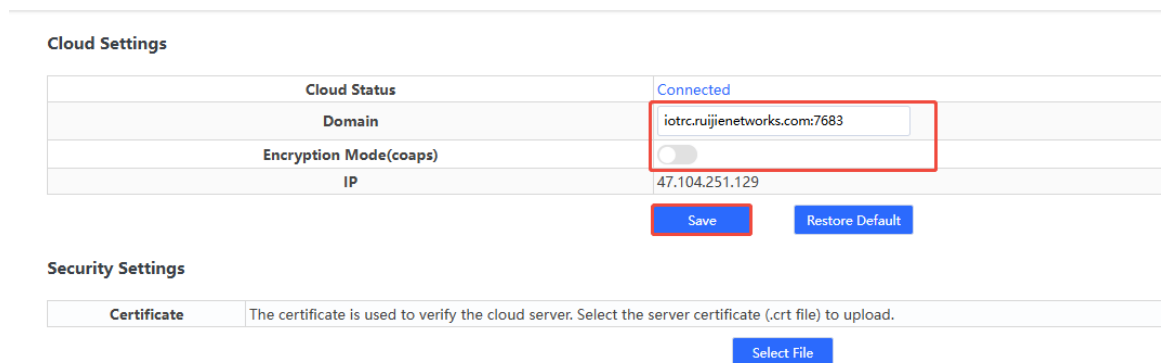

- After the web page is refreshed, if **Cloud Status** changes to **Connected**, disabling the encryption mode (CoAPs) is successful.

Figure 8-3 Succeeded in Disabling the Encryption Mode

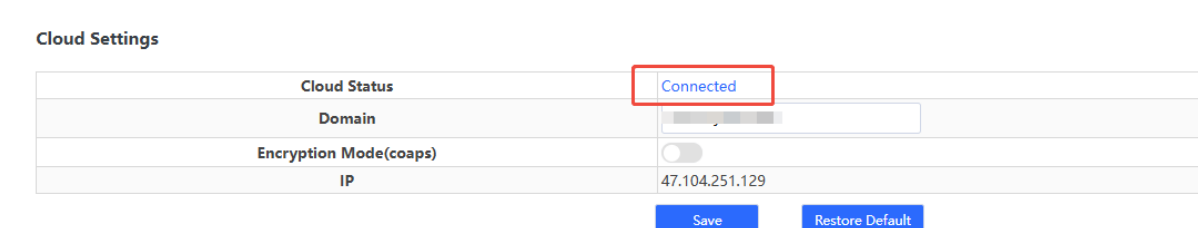

- Enable **Encryption Mode(coaps)** again.
 - Click **Restore Default**. A prompt is displayed.

- b After confirming the prompt information, click **OK**.

Figure 8-4 Enabling the Encryption Mode

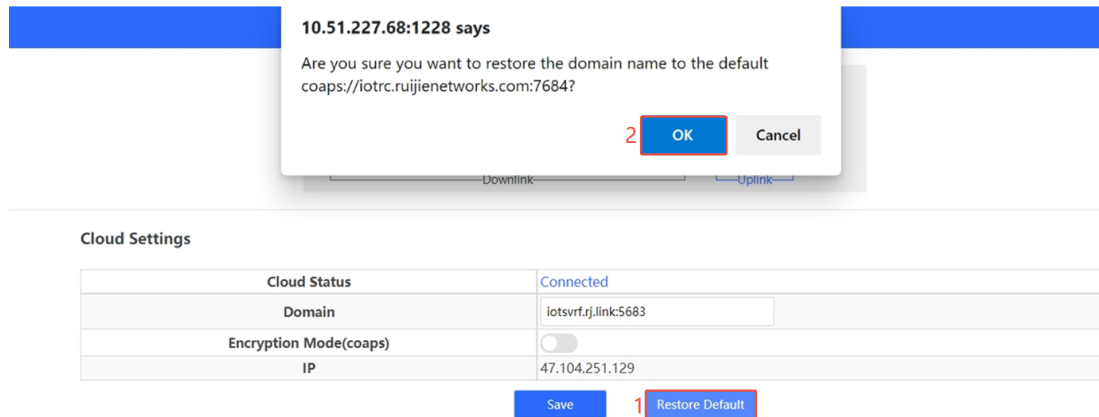

- c After the web page is refreshed, if **Cloud Status** changes to **Connected**, enabling the encryption mode (CoAPs) is successful.

Figure 8-5 Succeeded in Enabling the Encryption Mode

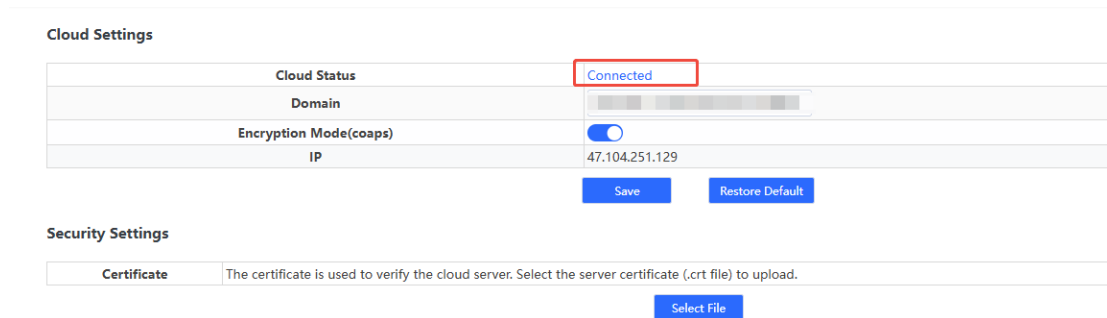

2. Private Cloud of RG-OCE Network Manager

After **Encryption Mode(coaps)** is enabled, to enable the encryption mode to take effect, you need to configure the domain name and port number, and upload the certificate of a private cloud server.

- (1) Obtain the certificate.

- a Log in to the private cloud server of RG-OCE Network Manager, choose **System > Certificates > Device Certificate for Cloud Service**, and click **Export Certificate**.

Figure 8-6 Downloading the Private Cloud Certificate (1/2)

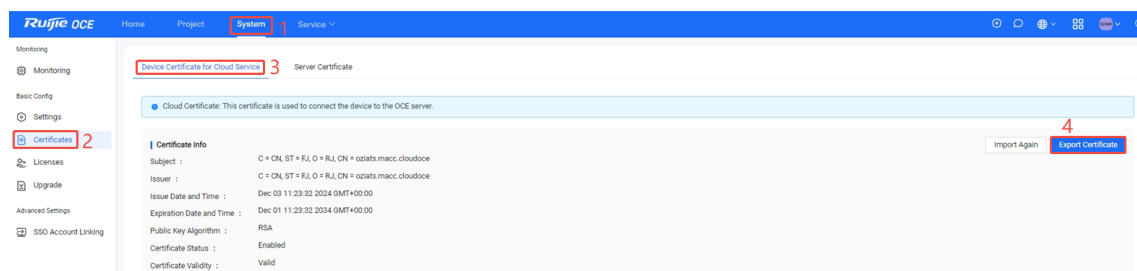

- b Set **Password-Protected File Export** to **No** and click **Export** to download the private cloud certificate.

Figure 8-7 Downloading the Private Cloud Certificate (2/2)

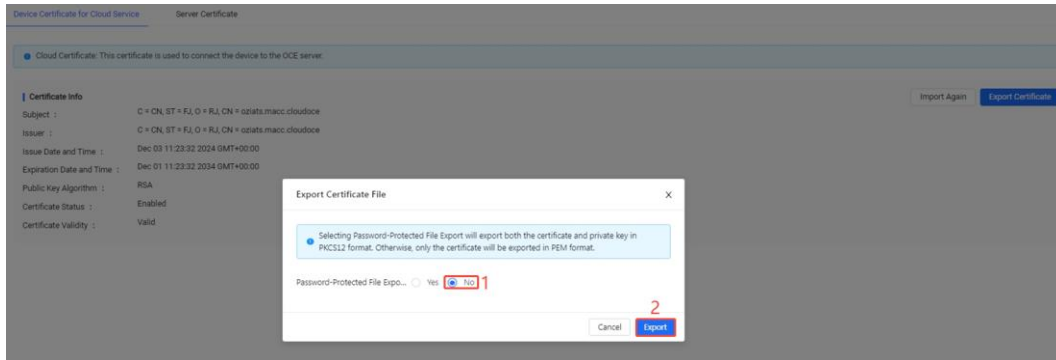

- (2) Configure the domain name and port number.

- a (Optional) Toggle on **Encryption Mode(coaps)** and click **Save** to enable the encryption mode.

Note

If **Encryption Mode(coaps)** is already toggled on, skip the step of enabling it.

Figure 8-8 Toggling on the Encryption Mode

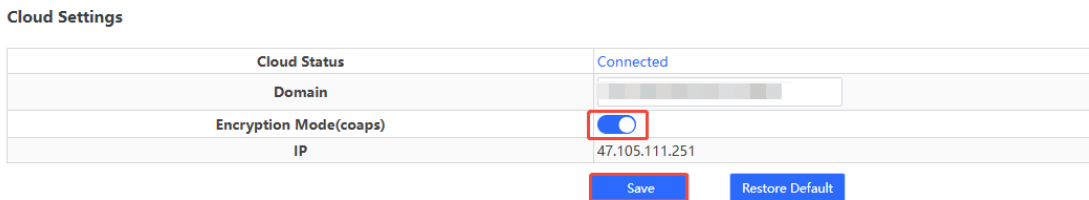

- b Confirm that the domain name of a private cloud server is used and the port number is changed to the management port number for CoAPs services. Click **Save**.

Note

- The management port number for CoAPs services needs to be planned and configured during deployment of the private cloud server of RG-OCE Network Manager.
- The domain name test1.ruijienetworks.com for a private server and the management port number 3200 of the CoAPs services are only used as examples. Set the domain name and port number as required.

Figure 8-9 Configuring the Domain Name and Port Number for a Private Cloud Server

Cloud Settings

Cloud Status	Unconnected
Reason	This device failed to connect to Ruijie Cloud.
Domain	test1.ruijienetworks.com:3200
Encryption Mode(coaps)	<input checked="" type="checkbox"/>
IP	47.105.111.251

Security Settings

Certificate The certificate is used to verify the cloud server. Select the server certificate (.crt file) to upload.

(3) Upload the certificate of a private cloud server.

- a Click **Select File**, select the downloaded certificate of a private cloud server, and upload the certificate.

Figure 8-10 Uploading the Certificate of a Private Cloud Server

Cloud Settings

Cloud Status	Connected
Domain	
Encryption Mode(coaps)	<input checked="" type="checkbox"/>
IP	47.104.251.

Security Settings

Certificate The certificate is used to verify the cloud server. Select the server certificate (.crt file) to upload.

- b When **Certificate uploaded** is displayed and **Cloud status** changes to **Connected**, the encryption mode is configured successfully.

To delete the imported certificate, click **Delete File**.

Figure 8-11 Succeeded in Uploading the Certificate

Cloud Settings

Cloud Status	Connected
Domain	
Encryption Mode(coaps)	<input checked="" type="checkbox"/>
IP	47.104.25

Security Settings

Certificate **Certificate uploaded:** no.crt

Caution

If you want to disable the encryption mode, change the port number to the management port number of the CoAP services, toggle off **Encrypted Mode(coaps)**, and click **Save**.

8.3 System Logs

Choose **Toolkit > Logs**.

System logs record the log generation time, log type, module that generates a log, and log details. System logs enable you to analyze and diagnose device status.

Figure 8-12 System Logs

Logs

Number	Time(UTC)	Type	Module	Details
1	1970/01/01 00:00:22	info	port	Port1 link up.

Caution

If the issue persists despite following the troubleshooting methods provided in this section, you may require remote support from a technician who will enable developer mode to resolve the issue.

9 System Settings

9.1 Managing Device Information

9.1.1 Viewing Device Information

Choose **Home** from the navigation page.

The **Device Info** pane on the **Home** page displays basic information about the device, including hostname, device model, serial number, firmware version, IP address, MAC address, cloud status, and uptime. You can view more information about the device by choosing **Monitoring > Device Info**.

Figure 9-1 Device Info

Device Info

Model: RG-ES2	Firmware Version: ESW_1.0(1)B1P50,Release(12190120)
MAC Address: 00:23:7	SN: MACCE
IP Address: 192.168.10.5	Uptime: 00h 34min 23s
Cloud Status: Connected Download App	Hostname: <input type="text"/> Edit

Figure 9-2 Viewing Device Information

Device Info

Hostname	ruijie
Model	RG-ES
MAC Address	00:23:
IP Address	192.168.10.5
Submask	255.255.255.0
Gateway	192.168.10.1
DNS	192.168.10.1
SN	MACCESW
Firmware Version	ESW_1.0(1)B1P50,Release(12190120)
Firmware Date	Jul 01 2025
Hardware Version	2.00

9.1.2 Editing the Hostname

Choose **Home** from the navigation page.

Enter the hostname and click **Edit** to edit the hostname in order to distinguish different devices.

Figure 9-3 Editing the Hostname

Device Info

Model: RG-ES	Firmware Version: ESW_1.0(1) Release(12190120)
MAC Address: 00:23:79	SN: MACCES
IP Address: 192.168.10.5	Uptime: 00h 37min 47s
Cloud Status: Connected Download App	Hostname: <input type="text" value="ruijie"/> Edit

9.1.3 Cloud Management

Choose **Home** from the navigation page.

Figure 9-6 Setting the Login Password

Account Settings

Account	admin	
Password	Password	Please enter 8-16 letters or numbers or special characters.
Confirm Password	Confirm Password	

[Save](#)

Caution

A new management password cannot be set on the **Account Settings** page in the following scenarios:

- This device, when in network-management mode, cannot be configured with an individual management password. You can log in to the primary device to modify the network-wide management password.
- If this device is managed by Ruijie Cloud or Ruijie Reyee App, you can modify the network-wide management password through Ruijie Cloud or Ruijie Reyee App. Changing the management password on the device will not synchronize the changes on Ruijie Cloud or Ruijie Reyee App with the device.

Figure 9-7 Network-Management Mode

Account Settings

Tip: This device is in network-management mode, and cannot be configured with an individual management password. Log in to [192.168.110.1](#) to modify the network-wide management password.

Account	admin
----------------	-------

Figure 9-8 Management Through Ruijie Cloud or Ruijie Reyee App

Account Settings

Tip: If this device is managed by Ruijie Cloud or Ruijie Reyee App, you can modify the network-wide management password through Ruijie Cloud or Ruijie Reyee. Changing the management password on the device will not synchronize the changes with Ruijie Cloud or Ruijie Reyee App. [Collapse](#)

Account	admin	
Password	Password	Please enter 8 to 16 letters or numbers or special characters.
Confirm Password	Confirm Password	

[Save](#)

9.3 Device Reboot

Choose **System > Reboot**.

Click **Reboot** to reboot the switch.

Figure 9-9 Device Reboot



9.4 System Upgrade

9.4.1 Local Upgrade

Choose **System > Upgrade**.

Click **Select File** to select the upgrade package from the local files (the upgrade package is a bin file. If it is a tar.gz file, you need to decompress the package and select the bin file for upgrade).

Keep Old Config is selected by default. That means the current configuration will be saved after device upgrade. If there is a huge difference between the current version and the upgrade version, you are advised not to select **Keep Old Config**.

Figure 9-10 Local Upgrade

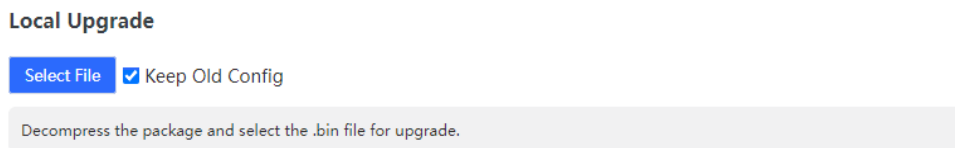

9.4.2 Online Upgrade

Choose **System > Upgrade**.

When there is a new version in the cloud, the version number of the latest version will be displayed on this page, and the **Upgrade** button will become available. The device will download the installation package of the recommended version from the cloud and it will be updated to the latest version. Online upgrade will keep the old configuration by default.

Figure 9-11 Online Upgrade

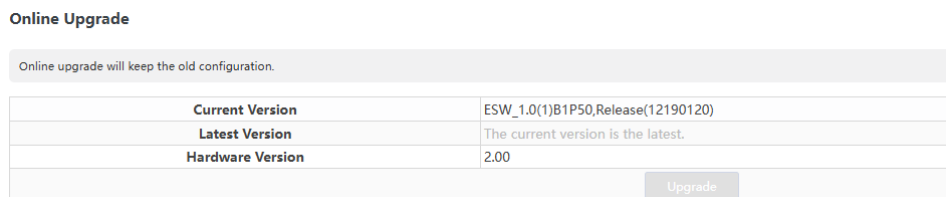

Note

The time that online upgrade takes depends on the current network speed. It may take some time. Please be patient.

9.5 Restoring Factory Configuration

Choose **System** > **Reset**.

Click **Reset** to restore factory configuration and reboot the device.

Figure 9-12 Restoring Factory Configuration

Reset

Reset the device to factory settings and restart it.

Reset

10 Monitoring

10.1 Cable Test

Note

This feature is not supported on an SFP port.

Choose **Monitoring > Cable Test**.

Cable Test allows you to check the status of Ethernet cables. For example, you can check whether the cables are short-circuited or disconnected.

Select the ports you want to detect, and then click **Start** to start cable diagnostics. The test result will be displayed accordingly. Click **Start All** to perform one-click cable diagnostics on all ports.

Figure 10-1 Cable Test

Cable Test

<input type="checkbox"/>	Port	Test Result	Details
<input type="checkbox"/>	Port 1	Normal	The cable works well.
<input type="checkbox"/>	Port 2	Disconnected	Please check cable connection or replace the cable.
<input type="checkbox"/>	Port 3	Disconnected	Please check cable connection or replace the cable.
<input type="checkbox"/>	Port 4	Disconnected	Please check cable connection or replace the cable.
<input type="checkbox"/>	Port 5	Disconnected	Please check cable connection or replace the cable.
<input type="checkbox"/>	Port 6	Disconnected	Please check cable connection or replace the cable.
<input type="checkbox"/>	Port 7	Disconnected	Please check cable connection or replace the cable.
<input type="checkbox"/>	Port 8	Disconnected	Please check cable connection or replace the cable.
<input type="checkbox"/>	Port 9	Unsupported	The port does not support cable diagnostics.
<input type="checkbox"/>	Port 10	Unsupported	The port does not support cable diagnostics.

Caution

If you select an uplink port for diagnostics, the network may be intermittently disconnected. Exercise caution when performing this operation.

10.2 Multi-DHCP Alarming

Caution

Multi-DHCP alarming will fail when the device IP address is not obtained dynamically. For relevant IP address configuration, see [3.7 Management IP Address](#).

Choose **Home** from the navigation page.

When there are multiple DHCP servers in a LAN, the system will send a conflicting alarm. An alarming message will be displayed in the **Device Info** column.

Figure 10-2 Multi-DHCP Alarming



Move the cursor to  to view the alarm details, including the VLAN where the conflicts occur, port, IP address of DHCP server, and MAC address.

10.3 Viewing Switches on the Network

Choose **Monitoring > Device List**.

- Primary device for global management
If the switch is under uniform management, some features cannot be configured independently (such as password settings). To facilitate configuration, information of the primary device in the VLAN will be displayed on this page. Click the IP address of the primary device to access the **Primary Device** page for global configuration.
- Devices in the same management VLAN
The device is able to automatically discover other switches in the same management VLAN. Information of these switches will be displayed in **Switch List**.
The first row of **Switch List** displays information of the current device, and the following rows display information of other devices. Click the **IP address** of a device to access eWeb of the device (login required).

Figure 10-3 Viewing Switches on the Network

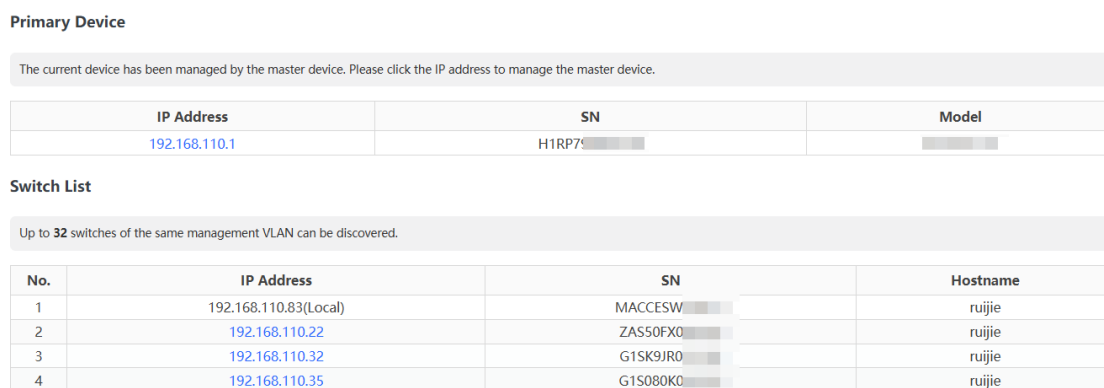

Note

The number of switches that can be discovered varies with product models.

11 FAQs

11.1 I failed to log in to eWeb. What can I do#

- (1) Verify that an Ethernet cable is properly connected to the LAN port of the device and the LED blinks or is steady on.
- (2) Before accessing eWeb, you are advised to configure a static IP address for a PC on the same network segment as the device IP address (default device IP address: 10.44.77.200 and subnet mask: 255.255.255.0). For example, set the IP address of the PC to 10.44.77.100 and the subnet mask to 255.255.255.0.
- (3) Run the **ping** command to test the connectivity between the PC and the device.
- (4) If the login failure persists, restore the device to factory settings.

11.2 What can I do if I forget my password# How can I restore the factory settings#

Caution

Press and hold the **Reset** button on the device panel for more than 5 seconds. This action will restore the device to factory settings, clearing all configurations. Exercise caution when performing this operation.

If you forget the password and cannot log in to the device, follow these steps:

- (1) With the device powered on, press and hold the **Reset** button on the device panel for more than 5 seconds. Release the button when the system LED blinks to restore the device to factory settings.
- (2) Once the device restarts, log in to eWeb using the default management IP address (10.44.77.200).
- (3) On the login page, set a new password and use it to log in to the device.